



AVTECH ELECTROSYSTEMS LTD.

NANOSECOND WAVEFORM ELECTRONICS
SINCE 1975

□ P.O. BOX 265
OGDENSBURG, NY
U.S.A. 13669-0265
TEL: (315) 472-5270
FAX: (613) 226-2802

TEL: 1-800-265-6681
FAX: 1-800-561-1970

e-mail: info@avtechpulse.com
<http://www.avtechpulse.com>

□ P.O. BOX 5120 STN. F
OTTAWA, ONTARIO
CANADA K2C 3H4
TEL: (613) 226-5772
FAX: (613) 226-2802

INSTRUCTIONS

MODEL AVX-D-ED PULSE GENERATOR

S.N.:

WARRANTY

Avtech Electrosystems Ltd. warrants products of its manufacture to be free from defects in material and workmanship under conditions of normal use. If, within one year after delivery to the original owner, and after prepaid return by the original owner, this Avtech product is found to be defective, Avtech shall at its option repair or replace said defective item. This warranty does not apply to units which have been disassembled, modified or subjected to conditions exceeding the applicable specifications or ratings. This warranty is the extent of the obligation assumed by Avtech with respect to this product and no other warranty or guarantee is either expressed or implied.

TECHNICAL SUPPORT

Phone: 613-226-5772 or 1-800-265-6681

Fax: 613-226-2802 or 1-800-561-1970

E-mail: info@avtechpulse.com

World Wide Web: <http://www.avtechpulse.com>

TABLE OF CONTENTS

WARRANTY 2

TABLE OF CONTENTS 3

AVX-D SERIES DATA SHEET 4

FRONT & BACK PANEL CONTROLS 5

Manual Reference: Q:\office\instructword\Avx-d\AVX-D-ED, edition 1.doc, created July 25, 2001

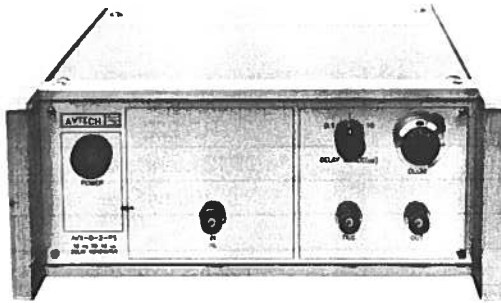

AVX-D-2-PS

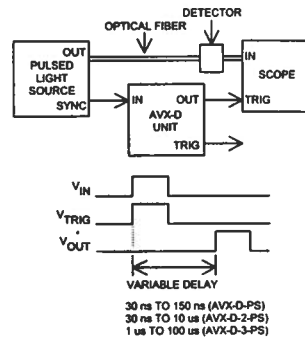

- 30 to 150 ns delays
- 30 ns to 10 μ s delays
- 1 μ s to 100 μ s delays
- Jitter as low as \pm 10 ps
- TTL signal levels
- Will drive 50 Ohm loads

The three models in the AVX-D analog delay generator series feature low-jitter variable delays in the ranges of 30 ns to 150 ns (Model AVX-D-PS), 30 ns to 10 μ s (Model AVX-D-2-PS), and 1 μ s to 100 μ s (Model AVX-D-3-PS). Model AVX-D-PS offers a very low jitter of \pm 10 ps. Model AVX-D-2-PS exhibits a jitter of \pm 30 ps at the minimum delay setting, increasing to \pm 300 ps at the maximum delay setting. The jitter for the longer-delay Model AVX-D-3-PS is specified as \pm 300 ps. All signals are TTL compatible and the output pulses will drive loads as low as 50 Ohms. The IN trigger pulse in all models is split into an output TRIG pulse (equal to the width of the IN pulse and delayed by about 20 ns) and an OUT pulse having a fixed width of about 250 ns. The delay between the leading edges of the IN and OUT pulses in Model AVX-D-PS (30 to 150 ns) is controlled via a one-turn control, while the delay in Models AVX-D-2-PS and AVX-D-3-PS (30 ns to 10 μ s and 1 μ s to

100 μ s, respectively) is controlled by 10-turn dial reading pots and range switches. Model AVX-D-PS is also available with an optional electronic delay control (0 to +10 Volts).

The input and output waveforms for the various models are illustrated above along with an example of a possible application where the delay generator is used to compensate for the propagation delay through an optical fiber.

The units will operate at PRF as high as 1.0 MHz provided the delay setting does not exceed one-half of the period of the PRF. Units with the -PS suffix require 110/220V (switchable), 50-60 Hz prime power while units without the -PS suffix (i.e. modules) require +15 V DC prime power.

| Model: | AVX-D-PS ¹ AVX-D | AVX-D-2-PS ¹ AVX-D-2 | AVX-D-3-PS ¹ AVX-D-3 |
|---------------------------------------|--|---|---|
| Delay range ² : | 30 ns to 150 ns | 30 ns to 10 μ s (3-position range switch) | 1 μ s to 100 μ s (2-position range switch) |
| Jitter: (Ext trig in to pulse out) | \pm 10 ps | \pm 30 ps to \pm 300 ps max | \pm 300 ps |
| Output amplitude: | + 5 V (TTL) will drive 50 Ohm loads | | |
| Trigger required: | Modules and -PS units: +5 Volt, 50 to 500 ns (TTL) | | |
| OUT pulse width: | 250 ns | | |
| Trig PW: | Equals input PW | | |
| PRF: | 0 to 1 MHz | 0 to 1 MHz (50% max duty cycle) | 0 to 50 kHz (50% max duty cycle) |
| Connectors: | -PS: Modules: | Out: BNC, Trig: BNC, In: BNC Out: SMA, Trig: SMA, In: SMA, | In: BNC Power: Solder terminals |
| Power requirement: | -PS: Modules: | 120/240 Volts (switchable) 50 - 60 Hz + 15 Volt, 200 mA | |
| Dimensions: (H x W x D) | -PS: Modules: | 100 mm x 215 mm x 375 mm (3.9" x 8.5" x 14.8") 43 mm x 66 mm x 107 mm (1.7" x 2.6" x 4.2") | |

1) -PS suffix indicates line powered instrument requiring external trigger. No suffix indicates miniature module requiring DC power and external trigger. (See page 112 for additional details of the basic instrument formats).

2) For electronic control (0 to + 10 V) of delay in Models AVX-D or AVX-D-PS suffix model No. with -ED.

FRONT & BACK PANEL CONTROLS

- (1) $\pm 15V$. Applies basic prime power to all stages.
- (2) ED. Controls the relative delay between the output pulse provided at OUT (5) and IN (3). This delay is varied over the range of 30 to about 150 ns by applying 0 to +10 VDC to the "ED" solder terminal ($R_{IN} \geq 10K$).
- (3) IN. Apply TTL input at this SMA terminal ($PW > 50$ ns).
- (4) TRIG. Replica of IN pulse delayed by 30 ns appears here. Will drive 50 Ohms.
- (5) OUT. +5 Volt output to 50 Ohms. This SMA output is delayed 30 to 150 ns with respect to the IN pulse.

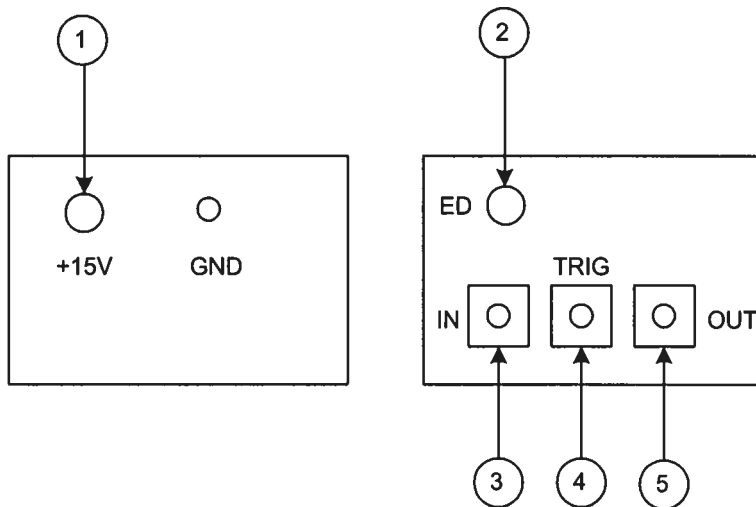

July 25/2001