



AVTECH ELECTROSYSTEMS LTD.

NANOSECOND WAVEFORM ELECTRONICS
SINCE 1975

□ P.O. BOX 265
OGDENSBURG, NY
U.S.A. 13669-0265
TEL: (315) 472-5270
FAX: (613) 226-2802

TEL: 1-800-265-6681
FAX: 1-800-561-1970

e-mail: info@avtechpulse.com
<http://www.avtechpulse.com>

□ P.O. BOX 5120 STN. F
OTTAWA, ONTARIO
CANADA K2C 3H4
TEL: (613) 226-5772
FAX: (613) 226-2802

INSTRUCTIONS

MODEL AVX-S1-KSA BIAS TEE

S.N.:

WARRANTY

Avtech Electrosystems Ltd. warrants products of its manufacture to be free from defects in material and workmanship under conditions of normal use. If, within one year after delivery to the original owner, and after prepaid return by the original owner, this Avtech product is found to be defective, Avtech shall at its option repair or replace said defective item. This warranty does not apply to units which have been disassembled, modified or subjected to conditions exceeding the applicable specifications or ratings. This warranty is the extent of the obligation assumed by Avtech with respect to this product and no other warranty or guarantee is either expressed or implied.

TECHNICAL SUPPORT

Phone: 613-226-5772 or 1-800-265-6681

Fax: 613-226-2802 or 1-800-561-1970

E-mail: info@avtechpulse.com

World Wide Web: <http://www.avtechpulse.com>

TABLE OF CONTENTS

WARRANTY 2

TABLE OF CONTENTS 3

FIG. 1: TEST ARRANGEMENT 4

GENERAL OPERATING INSTRUCTIONS 5

AVX-S1-KSA FUNCTIONAL EQUIVALENT CIRCUIT 6

PERFORMANCE CHECK SHEET 7

Manual Reference: Q:\office\instructword\AVX-S1AVX-S1-KSAeda-fig.doc, created June 13, 2000

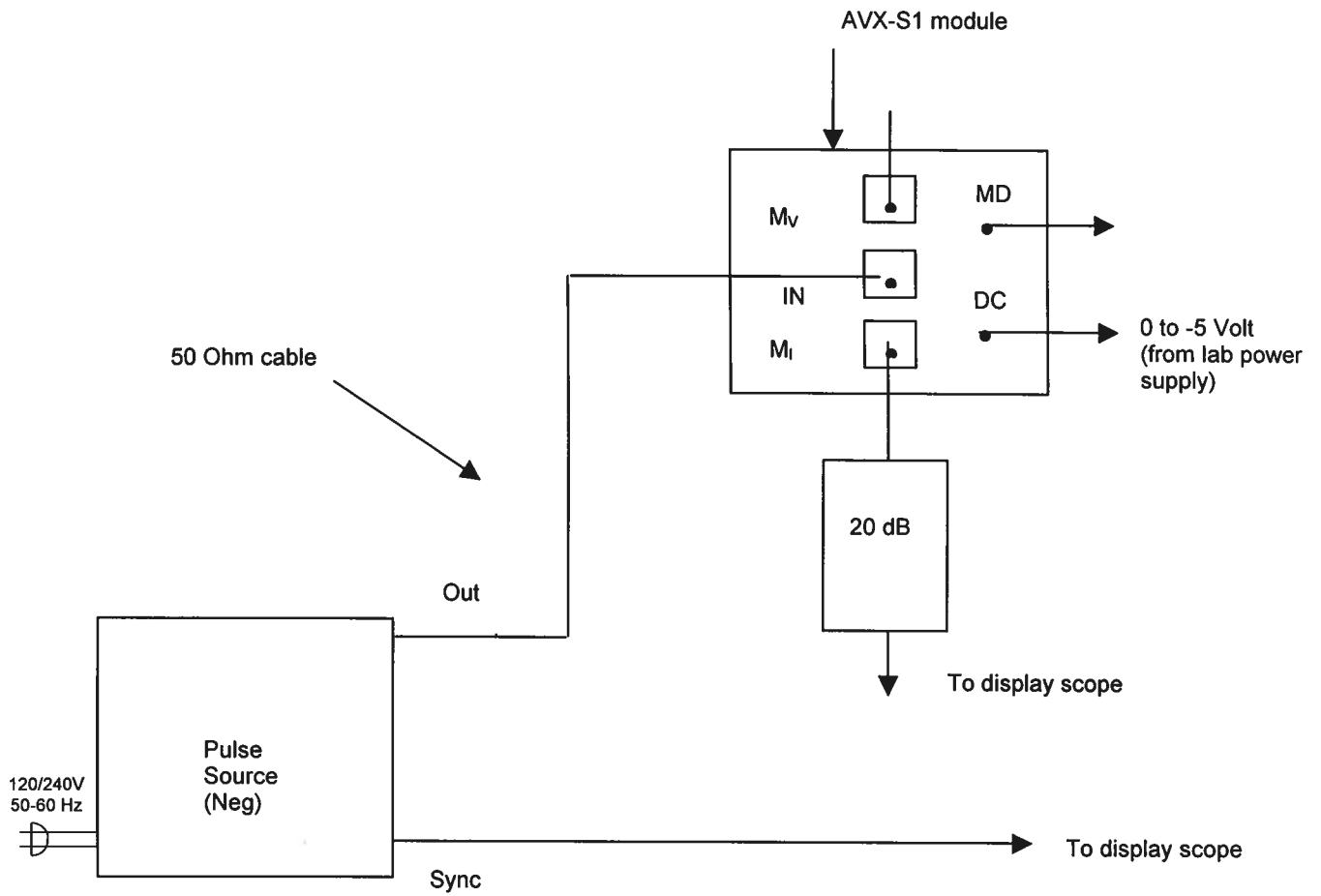
FIG. 1: TEST ARRANGEMENT

AVX-S1-KSA FUNCTIONAL EQUIVALENT CIRCUIT

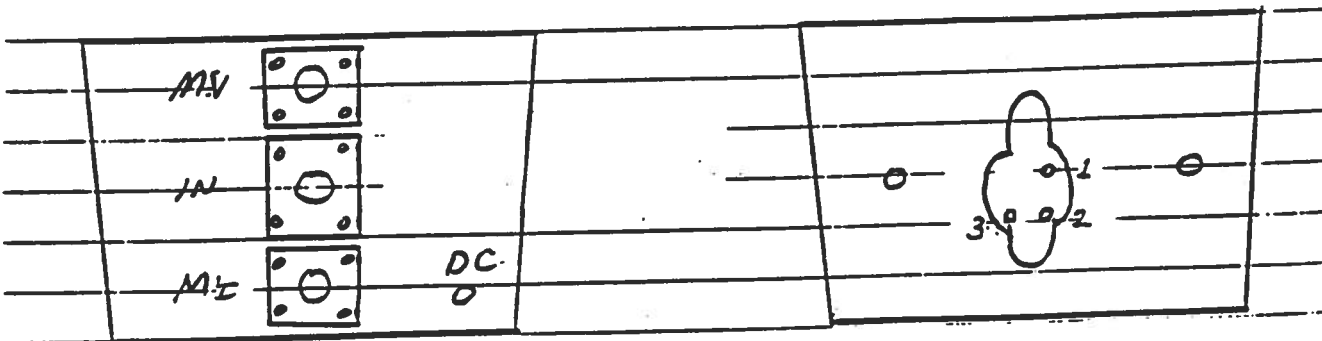
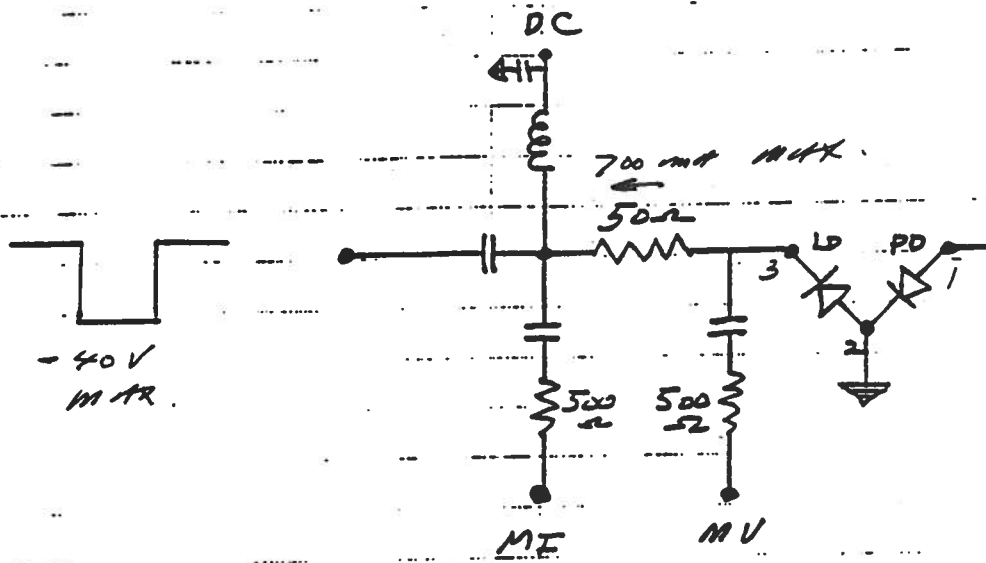

PACKAGE

GENERAL OPERATING INSTRUCTIONS

- 1) A general description of the AVX-S1 module is given in the enclosed data sheet.
- 2) The AVX-S1 module should be connected to your pulse source via a 50 Ohm cable (supplied).
- 3) The laser diode plugs directly into the socket on the side of the AVX-S1 module.
- 4) A forward DC bias may be applied to the laser diode by connecting a DC potential of 0 to -5 Volts to the DC solder terminal.
- 5) The diode pulse current may be monitored by connecting the MI and MV output ports to the sampling scope via 20 dB attenuators. The output amplitude (V_{MI} and V_{MV} , Volts) and diode current (I_D , Amp) are related as follows:

$$I_D = 0.2 (V_{MI} - V_{MV})$$

The laser diode voltage is given by the following:

$$V_D = 10 V_{MV}$$