



# AVTECH ELECTROSYSTEMS LTD.

NANOSECOND WAVEFORM ELECTRONICS  
SINCE 1975

□ P.O. BOX 265  
OGDENSBURG, NY  
U.S.A. 13669-0265  
TEL: (315) 472-5270  
FAX: (613) 226-2802

TEL: 1-800-265-6681  
FAX: 1-800-561-1970

e-mail: [info@avtechpulse.com](mailto:info@avtechpulse.com)  
<http://www.avtechpulse.com>

□ P.O. BOX 5120 STN. F  
OTTAWA, ONTARIO  
CANADA K2C 3H4  
TEL: (613) 226-5772  
FAX: (613) 226-2802

## INSTRUCTIONS

MODEL AVX-S1-MV BIAS INSERTION UNIT

S.N.: 9755

### WARRANTY

Avtech Electrosystems Ltd. warrants products of its manufacture to be free from defects in material and workmanship under conditions of normal use. If, within one year after delivery to the original owner, and after prepaid return by the original owner, this Avtech product is found to be defective, Avtech shall at its option repair or replace said defective item. This warranty does not apply to units which have been disassembled, modified or subjected to conditions exceeding the applicable specifications or ratings. This warranty is the extent of the obligation assumed by Avtech with respect to this product and no other warranty or guarantee is either expressed or implied.

### TECHNICAL SUPPORT

Phone: 613-226-5772 or 1-800-265-6681

Fax: 613-226-2802 or 1-800-561-1970

E-mail: [info@avtechpulse.com](mailto:info@avtechpulse.com)

World Wide Web: <http://www.avtechpulse.com>

## TABLE OF CONTENTS

WARRANTY .....	2
TABLE OF CONTENTS .....	3
FIG. 1: PULSE GENERATOR TEST ARRANGEMENT.....	4
GENERAL OPERATING INSTRUCTIONS .....	5
AVX-S1-MV FUNCTIONAL EQUIVALENT CIRCUIT .....	6
AVX-S SERIES DATA SHEET .....	7
AVX-S SERIES SPECIFICATIONS .....	8
PERFORMANCE CHECK SHEET .....	9

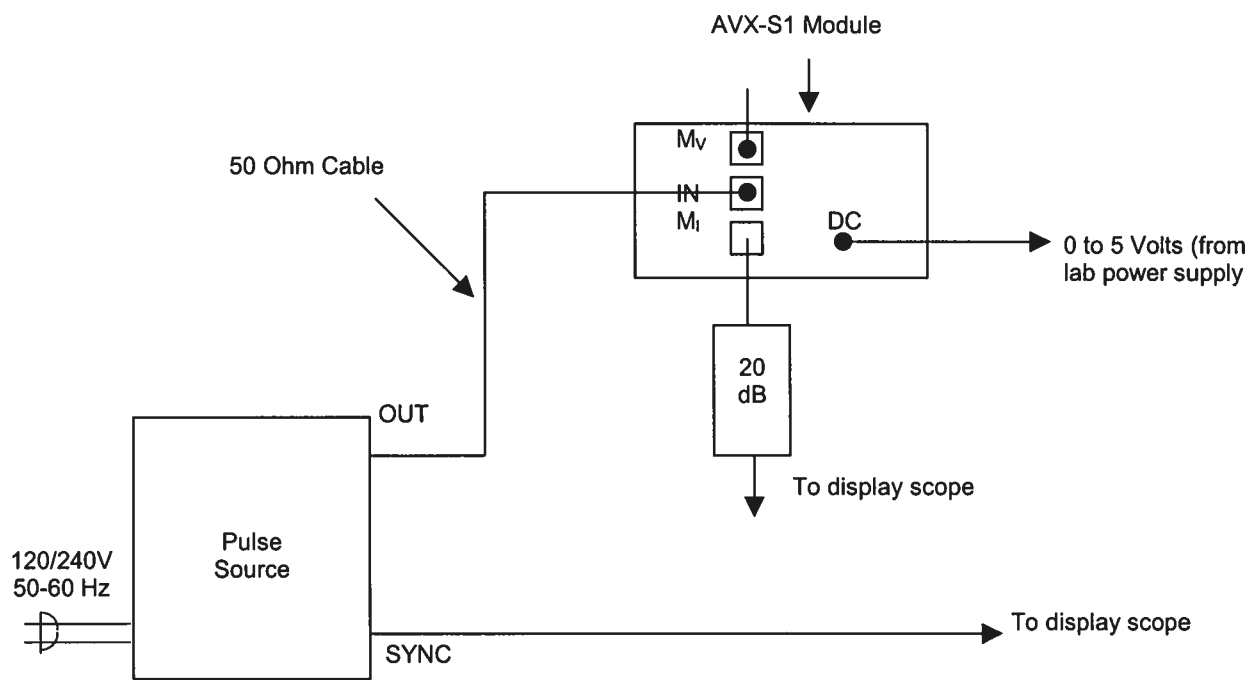
**FIG. 1: PULSE GENERATOR TEST ARRANGEMENT**

## GENERAL OPERATING INSTRUCTIONS

- 1) A general description of the AVX-S1 module is given in the enclosed data sheet.
- 2) The AVX-S1 module should be connected to your pulse source via a 50-Ohm cable (supplied).
- 3) The laser diode plugs directly into the socket on the side of the AVX-S1 module.
- 4) A DC bias may be applied to the laser diode by connecting a DC potential of 0 to 5 Volts to the DC solder terminal. This terminal must be shorted to ground if a forward bias is not required.
- 5) The diode pulse current may be monitored by connecting the MI and MV output ports to the sampling scope via 20 dB attenuators. The output amplitude ( $V_{MI}$  and  $V_{MV}$ , Volts) and diode current ( $I_D$ , Amp) are related as follows:

$$I_D = 0.2 (V_{MI} - V_{MV})$$

The laser diode voltage is given by the following:

$$V_D = 10 V_{MV}$$

AVX-S1-MV FUNCTIONAL EQUIVALENT CIRCUIT

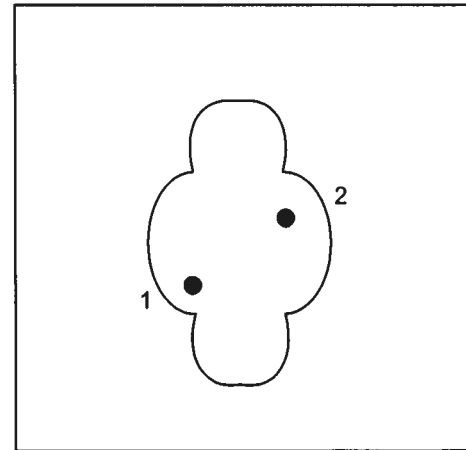
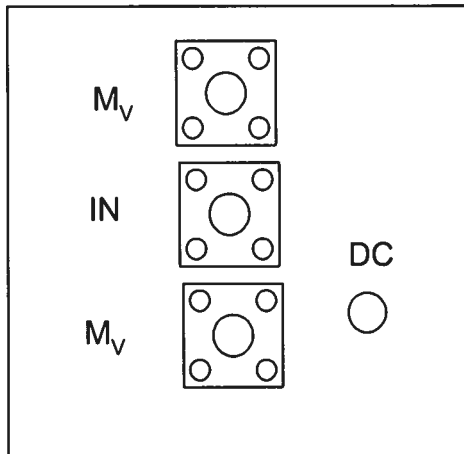
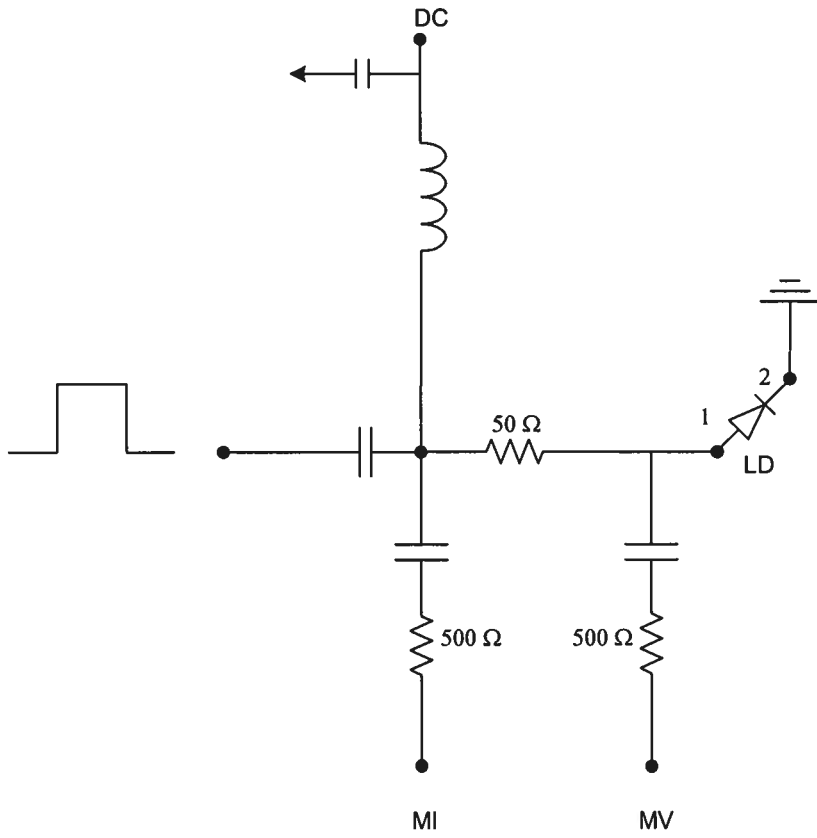

PACKAGE 1) LD Anode  
2) PD Anode

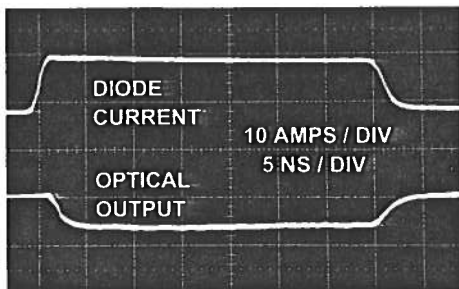

- Socket mounting of laser diodes
- Peak currents from 100 mA to 48 Amps
- Pulse widths from 0.4 to 200 ns
- Rise times from 0.2 to 2.0 ns
- Pulse or CW RF
- Diode voltage monitor and photodiode output options

The AVX-S series of bias insertion units is designed to combine a pulse or RF CW signal with a DC bias, and supply the resulting signal to a laser diode, which is inserted into a high quality socket included on the mount. The bias insertion module includes the necessary networks to match the laser diode to the pulse or RF source as well as networks for applying DC bias to the diode. An output for monitoring the diode current is included, and optional outputs allow for monitoring of the laser diode voltage and a photo detector diode output. Readily available socket configurations (TO-18, TO-5, TO-3, OP-3) are shown on the following page. Note that the laser diodes are not supplied with the AVX-S series.

The AVX-S series includes 3 basic models, namely the AVX-S1, AVX-S2 and the AVX-S3. The basic functional equivalent circuits for the three models are shown in Figures 1, 2, and 3 on page 75. Model AVX-S1 is specifically designed for ultra high-speed, low current applications (rise times as low as 200 ps, bandwidths to 100 MHz,  $I < 1.0$  Amp). Model AVX-S1 is employed in the AVO-9-C series of diode drivers. Model AVX-S2 is intended for application with rise times greater than 2 ns and currents above 1 Ampere. Model AVX-S3 is specifically designed for use with the AVO-2 and AVO-5 series pulse generators (which provide currents in the range of 5 to 50 Amperes).

The input series blocking capacitor in Models AVX-S1 and AVX-S2 presents a low impedance to RF CW signals and to baseband pulses, while the shunt inductor presents a high impedance to RF (or pulse) signals but an extremely low impedance to the DC bias. The resistor in series with the laser diode is selected to insure that the impedance at the IN port is 50 Ohms. Normally a laser diode resistance of 3 Ohms is assumed.

The diode current monitor ( $M_I$ ) is a standard feature that provides an output waveform (to 50 Ohms) which is an attenuated replica of the laser diode current. The output amplitude ( $V_{MI}$ , Volts) and diode current ( $I_D$ , Amps) are related as follows:

$$\text{Fig. 1: } I_D = 0.2 (V_{MI} - V_{MV}) \quad \text{Fig. 2: } I_D = 0.2 V_{MI}$$

The optional diode voltage monitor (MV) provides an output waveform that may be related to the voltage across the laser diode ( $V_D$ , Volts) as follows:

$$\text{Fig. 1: } V_D = 10 V_{MV} \quad \text{Fig. 2: } V_D = 10 (V_{MV} - V_{MI})$$

The  $-M_D$  option provides a connection to a photo diode detector output.

Model AVX-S3 is available in four different versions (AVX-S3A, AVX-S3B, AVX-S3C and AVX-S3D) all of which include a matching transformer which effectively boosts the laser diode current beyond that provided by the pulse source.

Model AVX-S3A is designed to match 50 Ohm pulse generators such as Model AVO-2-C to 12 Ohm loads with peak currents of 5 Amperes. Consequently, the resistor  $R_S$  in the equivalent circuit for this model is 10 Ohm. This resistor is accessible in all AVX-S3 models and may be changed by the user (by desoldering). The series resistance of the laser diode and the resistor  $R_S$  must equal the pulse generator source impedance divided by  $N^2$ . Consequently, if the series resistance of the laser diode is relatively high, it then may be necessary to reduce the value of  $R_S$ . Model AVX-S3B is designed to match 50 Ohm pulse generators such as Model AVO-5-C to 3 Ohms and will provide peak diode currents up to 28 Amperes. Model AVX-S3C is designed to match Models AVO-2W-C and AVO-2-C (25 Ohm source impedance) to load resistance of about 5 Ohms and will provide peak diode currents as high as 10 Amperes. Model AVX-S3D is designed for use with Model AVO-5B-C and will provide up to 48 Amperes of diode current.

One (or two) SMA output connectors provide attenuated coincident replicas of the diode current ( $-M_I$  current monitor feature) and diode voltage ( $-MV$  option) as per the following relationships (Amps, Volts):

$$I_D = \frac{10V_{MI}}{R_S} \quad V_D = 10 (V_{MV} - V_{MI})$$

All AVX-S3 units include two foot long input cables with SMA male connectors.

When ordering members of the AVX-S family, the customer must specify the basic model number (e.g. AVX-S1) and the following additional information:

- Diode package type (e.g. TO-18) and the required pin connections (e.g. anode, cathode, ground, etc.). See the following page for readily available package mounting. Contact Avtech for special or different packages.
- Desired options (e.g.  $-MV$ ,  $-MD$ ).

Contact Avtech for your special requirements.

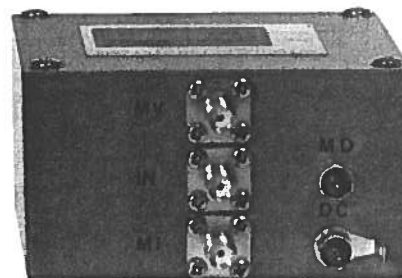
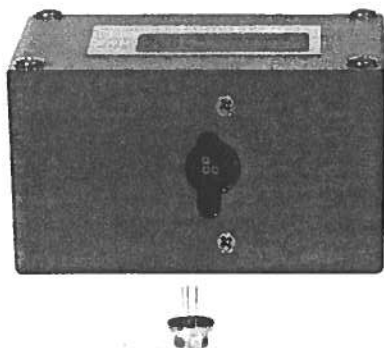

**SPECIFICATIONS**

**AVX-S SERIES**

Model:	AVX-S1	AVX-S2	AVX-S3A	AVX-S3B	AVX-S3C	AVX-S3D
Peak diode current:	400 mA	2 Amps	5 Amps	28 Amps	10 Amps	48 Amps
Max. input amplitude:	20 Volts	100 Volts	150 Volts	350 Volts	150 Volts	150 Volts
Pulse width (ns):	0.4 - 200	1 - 1000	2 - 100	2 - 100	2 - 100	5 - 500
Rise time (ns):	0.2	0.5	0.5	1.0	0.5	2.0
Pulse PRF range:	DC - 100 MHz	DC - 20 MHz	DC - 10 MHz	DC - 10 MHz	DC - 10 MHz	DC - 1 MHz
CW frequency range:	10 - 100 MHz	1 - 20 MHz	-	-	-	-
Max. bias current:	100 mA	100 mA	100 mA	100 mA	100 mA	100 mA
Max. bias voltage:	50 Volts	50 Volts	50 Volts	50 Volts	50 Volts	50 Volts
Input impedance:	50 Ohms	50 Ohms	50 Ohms	50 Ohms	25 Ohms	12 Ohms
N:	-	-	2	4	2	4
$R_s$ (Ohms):	-	-	10	3	5	0.7
IN connector:	SMA					
Monitor connector:	SMA					
Bias connector:	Solder pin					
Dimensions: (H x W x D)	41 mm x 66 mm x 76 mm (1.6" x 2.6" x 3.0")					
Material:	Cast aluminum, blue enamel					
Mounting:	Any					

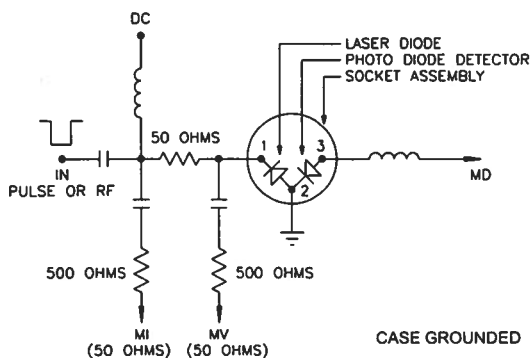

Fig. 1 - AVX-S1 and AVX-S2 functional equivalent circuit (preferred configuration)

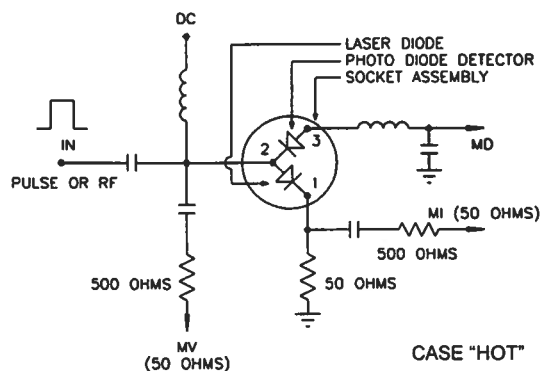

Fig. 2 - AVX-S1 and AVX-S2 functional equivalent circuit (alternative configuration)

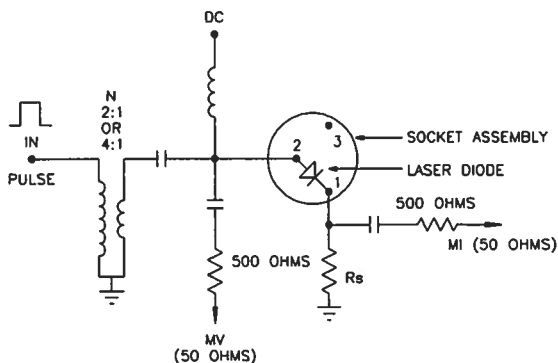

Fig. 3 - AVX-S3 functional equivalent circuit

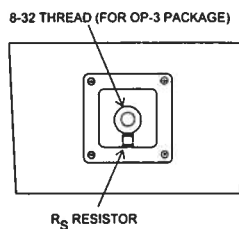
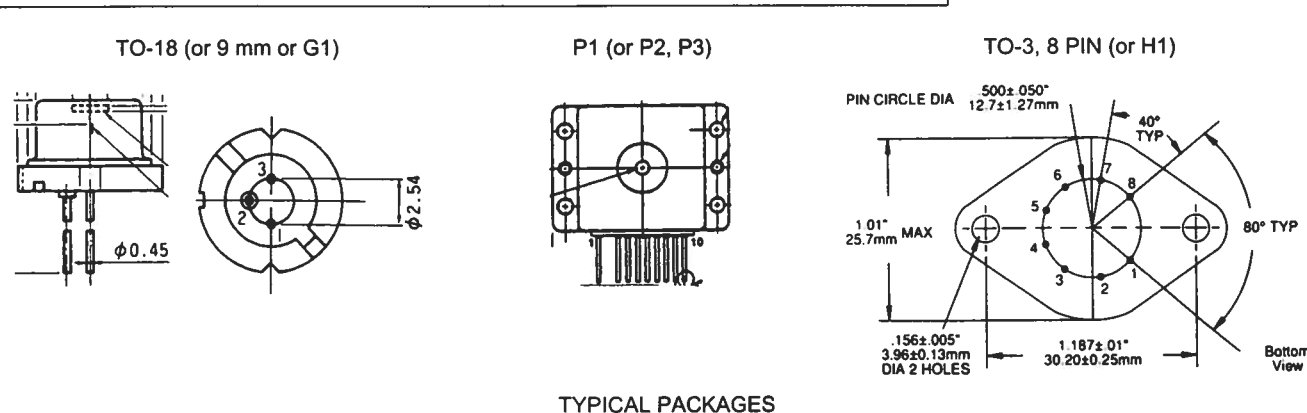
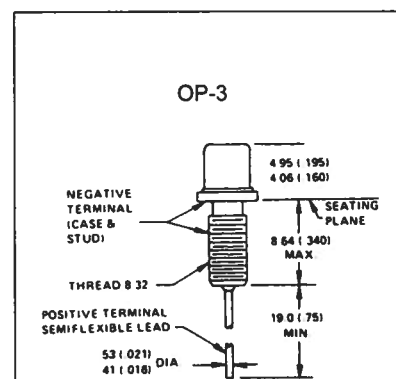

Fig. 4 - AVX-S3 input assembly (for OP-3 package)



LASER DIODE BIAS INSERTION UNITS (WITH DIODE SOCKETS)



July 20/2001