



# AVTECH ELECTROSYSTEMS LTD.

NANOSECOND WAVEFORM ELECTRONICS  
SINCE 1975

P.O. BOX 265  
OGDENSBURG, NY  
U.S.A. 13669-0265  
TEL: (315) 472-5270  
FAX: (613) 226-2802

TEL: 1-800-265-6681  
FAX: 1-800-561-1970

e-mail: [info@avtechpulse.com](mailto:info@avtechpulse.com)  
<http://www.avtechpulse.com/>

BOX 5120, LCD MERIVALE  
OTTAWA, ONTARIO  
CANADA K2C 3H4  
TEL: (613) 226-5772  
FAX: (613) 226-2802

## INSTRUCTIONS

MODELS AVX-STRA-PS,  
AVX-STRB-PS

ULTRA-FAST  
PULSE STRETCHERS

SERIAL NUMBER: \_\_\_\_\_

### WARRANTY

Avtech Electrosystems Ltd. warrants products of its manufacture to be free from defects in material and workmanship under conditions of normal use. If, within one year after delivery to the original owner, and after prepaid return by the original owner, this Avtech product is found to be defective, Avtech shall at its option repair or replace said defective item. This warranty does not apply to units which have been disassembled, modified or subjected to conditions exceeding the applicable specifications or ratings. This warranty is the extent of the obligation assumed by Avtech with respect to this product and no other warranty or guarantee is either expressed or implied.

### TECHNICAL SUPPORT

Phone: 613-226-5772 or 1-800-265-6681

Fax: 613-226-2802 or 1-800-561-1970

E-mail: [info@avtechpulse.com](mailto:info@avtechpulse.com)

World Wide Web: <http://www.avtechpulse.com>

TABLE OF CONTENTS

<b>WARRANTY</b> .....	<b>2</b>
<b>TECHNICAL SUPPORT</b> .....	<b>2</b>
<b>TABLE OF CONTENTS</b> .....	<b>3</b>
<b>INTRODUCTION</b> .....	<b>4</b>
<b>OPTIONAL FEATURES</b> .....	<b>4</b>
<b>SPECIFICATIONS</b> .....	<b>5</b>
<b>EC DECLARATION OF CONFORMITY</b> .....	<b>6</b>
<b>INSTALLATION</b> .....	<b>7</b>
<b>VISUAL CHECK</b> .....	<b>7</b>
<b>POWER RATINGS</b> .....	<b>7</b>
<b>CONNECTION TO THE POWER SUPPLY</b> .....	<b>7</b>
<b>ENVIRONMENTAL CONDITIONS</b> .....	<b>7</b>
<b>FUSES</b> .....	<b>8</b>
<b>AC FUSE REPLACEMENT</b> .....	<b>8</b>
<b>DC FUSE REPLACEMENT</b> .....	<b>9</b>
<b>FUSE RATINGS</b> .....	<b>9</b>
<b>FRONT PANEL CONTROLS</b> .....	<b>10</b>
<b>REAR PANEL CONTROLS</b> .....	<b>11</b>
<b>GENERAL INFORMATION</b> .....	<b>12</b>
<b>BASIC OPERATION</b> .....	<b>12</b>
<b>FALSE TRIGGERING CONSIDERATIONS</b> .....	<b>12</b>
<b>MECHANICAL INFORMATION</b> .....	<b>13</b>
<b>TOP COVER REMOVAL</b> .....	<b>13</b>
<b>ELECTROMAGNETIC INTERFERENCE</b> .....	<b>13</b>
<b>MAINTENANCE</b> .....	<b>13</b>
<b>REGULAR MAINTENANCE</b> .....	<b>13</b>
<b>CLEANING</b> .....	<b>13</b>
<b>PERFORMANCE CHECKSHEET</b> .....	<b>14</b>

## INTRODUCTION

The AVX-STR series is useful in experimental applications where an ultra-fast low-level pulse must be converted to standard logic levels and widened, to trigger other equipment.

The AVX-STRA-PS converts pulses with widths of 200 ps or higher, and amplitudes of 30 mV to 1V, to TTL levels (0 and +3 to +5V). The output pulse width is fixed at 50 ns, suitable for triggering most laboratory instruments. The input pulse repetition frequency may be as high as 10 MHz.

The AVX-STRB-PS handles slower, larger input pulses. This model converts pulses with widths of 2 ns or higher, and amplitudes of 300 mV to 3V, to TTL levels (0 and +3 to +5V). The output pulse width is fixed at 50 ns, suitable for triggering most laboratory instruments. The input pulse repetition frequency may be as high as 10 MHz.

All models require 100 - 240 Volts, 50 - 60 Hz prime power and are equipped with SMA input and output connectors.

This instrument is intended for use in research and development laboratories.

## OPTIONAL FEATURES

The following option is available for the AVX-STRA-PS and the AVX-STRB-PS:

-R5 option: Provides a wider rack-mountable chassis (100 x 430 x 375 mm, 3.9" x 17" x 14.8") with rack-mount kit.

SPECIFICATIONS

Model:	AVX-STRA-PS	AVX-STRB-PS
Input pulse width:	> 200 ps	> 2 ns
Input amplitude:	+30 mV to +1.0 V	+300 mV to +3.0 V
Input resistance:	50 Ohms	
Input pulse repetition frequency:	0 to 10 MHz	
Output amplitude:	TTL levels: Low: 0V High: +3 to +5V	
Output pulse width:	50 ns, fixed	
Propagation delay:	< 20 ns	
Connectors:	SMA	
Power requirement:	100 - 240 Volts, 50-60 Hz	
Dimensions <sup>1</sup> :	100 mm x 215 mm x 375 mm (3.9" x 8.5" x 14.8")	

1) Add -R5 option to specify wider rack-mountable chassis (100 x 430 x 375 mm, 3.9" x 17" x 14.8") with rack-mount kit.

EC DECLARATION OF CONFORMITY

We

Avtech Electrosystems Ltd.  
P.O. Box 5120, LCD Merivale  
Ottawa, Ontario  
Canada K2C 3H4

declare that this pulse generator meets the intent of Directive 89/336/EEC for Electromagnetic Compatibility. Compliance pertains to the following specifications as listed in the official Journal of the European Communities:

EN 50081-1 Emission

EN 50082-1 Immunity

and that this pulse generator meets the intent of the Low Voltage Directive 72/23/EEC as amended by 93/68/EEC. Compliance pertains to the following specifications as listed in the official Journal of the European Communities:

EN 61010-1:2001 Safety requirements for electrical equipment for measurement, control, and laboratory use



## INSTALLATION

### VISUAL CHECK

After unpacking the instrument mainframe and the transformer module, examine to ensure that they have not been damaged in shipment. Visually inspect all connectors, knobs, and handles. Confirm that a power cord and an instrumentation manual (this manual), are with the instrument. If the instrument has been damaged, file a claim immediately with the company that transported the instrument.

### POWER RATINGS

This instrument is intended to operate from 100 - 240 V, 50 - 60 Hz.

The maximum power consumption is 57 Watts. Please see the "FUSES" section for information about the appropriate AC and DC fuses.

This instrument is an "Installation Category II" instrument, intended for operation from a normal single-phase supply.

### CONNECTION TO THE POWER SUPPLY

An IEC-320 three-pronged recessed male socket is provided on the back panel for AC power connection to the instrument. One end of the detachable power cord that is supplied with the instrument plugs into this socket. The other end of the detachable power cord plugs into the local mains supply. Use only the cable supplied with the instrument. The mains supply must be earthed, and the cable used to connect the instrument to the mains supply must provide an earth connection. (The supplied cable does this.)

### ENVIRONMENTAL CONDITIONS

This instrument is intended for use under the following conditions:

- a) indoor use;
- b) altitude up to 2 000 m;
- c) temperature 5 °C to 40 °C;
- d) maximum relative humidity 80 % for temperatures up to 31 °C decreasing linearly to 50 % relative humidity at 40 °C;
- e) Mains supply voltage fluctuations up to  $\pm 10$  % of the nominal voltage;
- f) no pollution or only dry, non-conductive pollution.

## FUSES

This instrument contains four fuses. All are accessible from the rear-panel. Two protect the AC prime power input, and two protect the internal DC power supplies. The locations of the fuses on the rear panel are shown in the figure below:

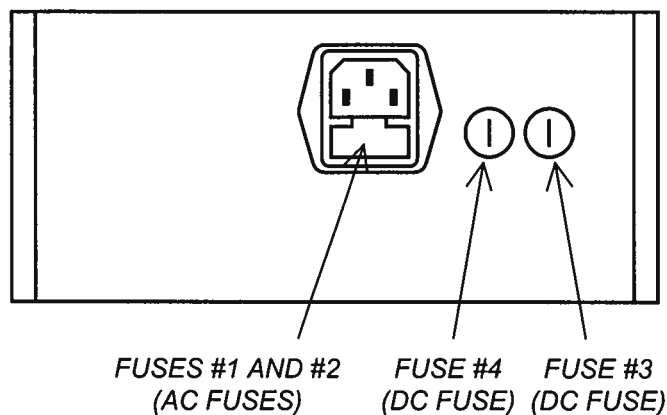

### AC FUSE REPLACEMENT

To physically access the AC fuses, the power cord must be detached from the rear panel of the instrument. The fuse drawer may then be extracted using a small flat-head screwdriver, as shown below:

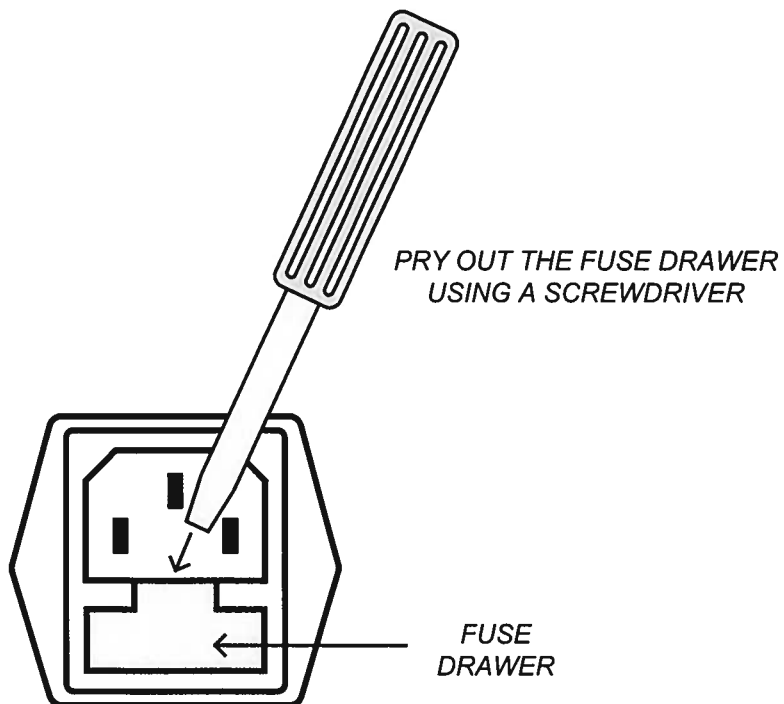



## DC FUSE REPLACEMENT

The DC fuses may be replaced by inserting the tip of a flat-head screwdriver into the fuse holder slot, and rotating the slot counter-clockwise. The fuse and its carrier will then pop out.

## FUSE RATINGS

The following table lists the required fuses:

Fuses	Mains Voltage	Rating	Case Size	Manufacturer's Part Number (Wickmann)	Distributor's Part Number (Digi-Key)
#1, #2 (AC)	115 V	0.25A, 250V, Time-Delay	5 x 20 mm	1950250000	WK5035-ND
	230 V	0.25A, 250V, Time-Delay	5 x 20 mm	1950250000	WK5035-ND
#3 (DC)	115/230V	0.5A, 250V, Time-Delay	5 x 20 mm	1950500000	WK5041-ND
#4 (DC)	115/230V	Not used. A spare 0.5A fuse is installed in this holder.			

The fuse manufacturer is Wickmann (<http://www.wickmann.com/>).

Replacement fuses may be easily obtained from Digi-Key (<http://www.digikey.com/>) and other distributors.

## FRONT PANEL CONTROLS

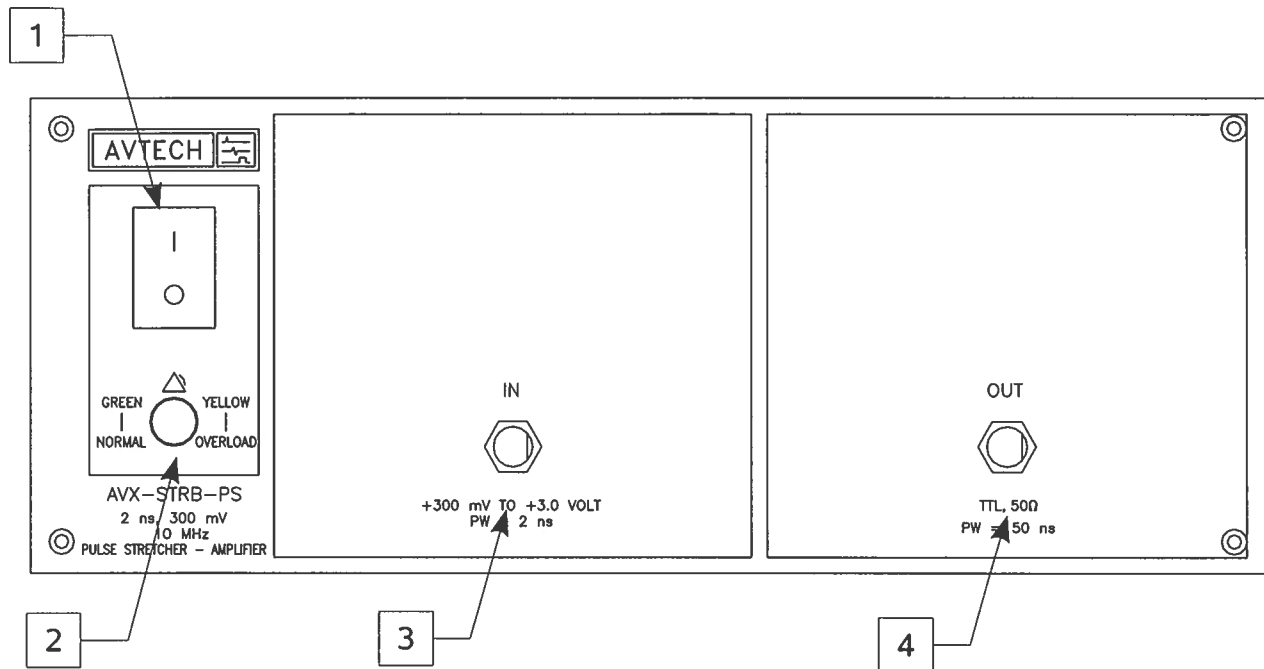

1. **POWER Switch.** This is the main power switch. When turning the instrument on, there may be a delay of several seconds before the instrument appears to respond.
2. **OVERLOAD Indicator.** When the instrument is powered, this indicator is normally green, indicating normal operation. If this indicator is yellow, an internal automatic overload protection circuit has been tripped. If the unit is overloaded (by operating at an exceedingly high duty cycle or by operating into a very low impedance), the protective circuit will disable the output of the instrument and turn the indicator light yellow. The light will stay yellow (i.e. output disabled) for about 5 seconds after which the instrument will attempt to re-enable the output (i.e. light green) for about 1 second. If the overload condition persists, the output will be disabled again (i.e. light yellow) for another 5 seconds. If the overload condition has been removed, the instrument will resume normal operation.  
  
This overload indicator may flash yellow briefly at start-up. This is not a cause for concern.
3. **IN Connector.** The input signal is applied to this SMA connector. The input impedance is 50Ω.
4. **OUT Connector.** This is the main output. A single TTL-level pulse (i.e. logic low = 0V, logic high = +3 to +5V) is generated for each input pulse. The output pulse width is fixed at approximately 50 ns. This output will drive loads of 50Ω or greater.

## REAR PANEL CONTROLS

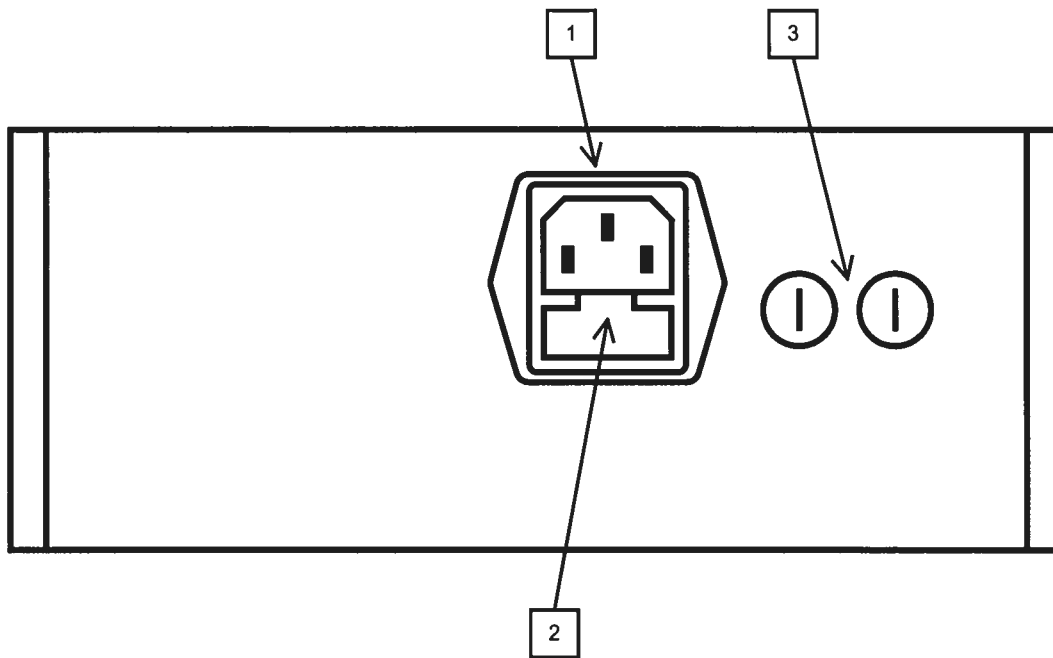

1. AC POWER INPUT. An IEC-320 C14 three-pronged recessed male socket is provided on the back panel for AC power connection to the instrument. One end of the detachable power cord that is supplied with the instrument plugs into this socket.

2. AC FUSE DRAWER. The two fuses that protect the AC input are located in this drawer. Please see the “FUSES” section of this manual for more information.

3. DC FUSES. These two fuses protect the internal DC power supplies. Please see the “FUSES” sections of this manual for more information.

## GENERAL INFORMATION

### BASIC OPERATION

This instrument has one pulse input and one pulse output.

The AVX-STRA-PS accepts an input of 200 ps or wider, with an amplitude of +30mV to +1V.

The AVX-STRB-PS accepts an input of 2 ns or wider, with an amplitude of +300mV to +3V.

For each input pulse, an output pulse is generated on the OUT connector. The output pulse has a fixed pulse width of approximately 50 ns, and operates at standard TTL logic levels (i.e. logic low = 0V, logic high = +3 to +5V). The IN-to-OUT propagation delay is less than 20 ns.

The basic input and output waveforms are illustrated below:

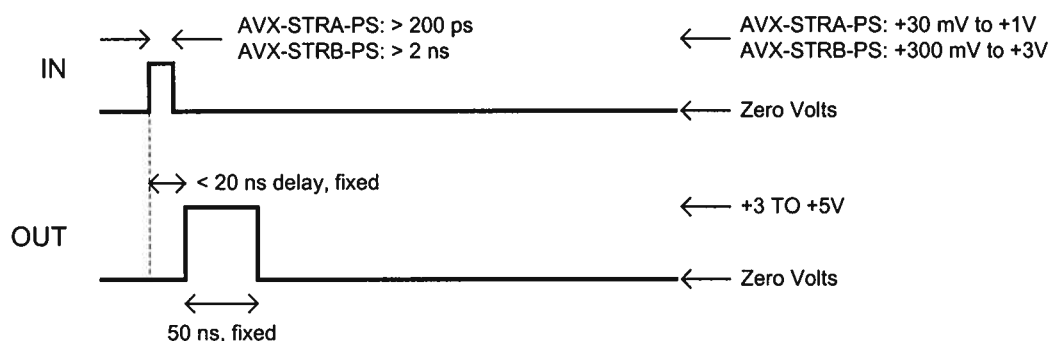

*Basic Operation*

### FALSE TRIGGERING CONSIDERATIONS

Due to the sensitive inputs of the AVX-STRA-PS and AVX-STRB-PS, care must be taken to avoid false triggering.

Use coaxial shielded cable to connect to the input connector, to avoid interference with other signals.

Also, if the input pulse amplitude is expected to be much larger than the minimum rated amplitude for the unit (30 mV for the AVX-STRA-PS, and 300 mV for the AVX-STRB-PS), consider adding a shielded coaxial attenuator at the input of this instrument. This will attenuate both the signal and any unwanted noise. (See the Avtech application note at <http://www.avtechpulse.com/appnote/vendors/> for suggested attenuator suppliers.)

## MECHANICAL INFORMATION

### TOP COVER REMOVAL

If necessary, the interior of the instrument may be accessed by removing the four Phillips screws on the top panel. With the four screws removed, the top cover may be slid back (and off).

Always disconnect the power cord before opening the instrument.

There are no user-adjustable internal circuits. For repairs other than fuse replacement, please contact Avtech (info@avtechpulse.com) to arrange for the instrument to be returned to the factory for repair.

 Caution: High voltages are present inside the instrument during normal operation. Do not operate the instrument with the cover removed.

### ELECTROMAGNETIC INTERFERENCE

To prevent electromagnetic interference with other equipment, all used outputs should be connected to shielded 50 $\Omega$  loads using shielded 50 $\Omega$  coaxial cables. Unused outputs should be terminated with shielded 50 $\Omega$  coaxial terminators or with shielded coaxial dust caps, to prevent unintentional electromagnetic radiation. All cords and cables should be less than 3m in length.

## MAINTENANCE

### REGULAR MAINTENANCE

This instrument does not require any regular maintenance.

On occasion, one or more of the four rear-panel fuses may require replacement. All fuses can be accessed from the rear panel. See the “FUSES” section for details.

### CLEANING

If desired, the interior of the instrument may be cleaned using compressed air to dislodge any accumulated dust. (See the “TOP COVER REMOVAL” section for instructions on accessing the interior.) No other cleaning is recommended.

Nov. 4 / 03