



# AVTECH ELECTROSYSTEMS LTD.

NANOSECOND WAVEFORM ELECTRONICS  
SINCE 1975

☐ P.O. BOX 265  
OGDENSBURG, NY  
U.S.A. 13669-0265  
TEL: (315) 472-5270  
FAX: (613) 226-2802

TEL: 1-800-265-6681  
FAX: 1-800-561-1970

e-mail: [info@avtechpulse.com](mailto:info@avtechpulse.com)  
<http://www.avtechpulse.com>

☐ P.O. BOX 5120 STN. F  
OTTAWA, ONTARIO  
CANADA K2C 3H4  
TEL: (613) 226-5772  
FAX: (613) 226-2802

## INSTRUCTIONS

MODEL AVPP-2-C-P-EA-EW-P PULSE GENERATOR

S.N.:

### WARRANTY

Avtech Electrosystems Ltd. warrants products of its manufacture to be free from defects in material and workmanship under conditions of normal use. If, within one year after delivery to the original owner, and after prepaid return by the original owner, this Avtech product is found to be defective, Avtech shall at its option repair or replace said defective item. This warranty does not apply to units which have been disassembled, modified or subjected to conditions exceeding the applicable specifications or ratings. This warranty is the extent of the obligation assumed by Avtech with respect to this product and no other warranty or guarantee is either expressed or implied.

### TECHNICAL SUPPORT

Phone: 613-226-5772 or 1-800-265-6681

Fax: 613-226-2802 or 1-800-561-1970

E-mail: [info@avtechpulse.com](mailto:info@avtechpulse.com)

World Wide Web: <http://www.avtechpulse.com>

## TABLE OF CONTENTS

WARRANTY.....	2
TABLE OF CONTENTS .....	3
FIG. 1: PULSE GENERATOR TEST ARRANGEMENT .....	4
GENERAL OPERATING INSTRUCTIONS .....	5
FIG. 2: FRONT PANEL CONTROLSFRONT PANEL CONTROLS.....	8
FRONT PANEL CONTROLS .....	9
FIG. 3: BACK PANEL CONTROLS - (FOR UNITS WITHOUT THE OT OR EO OPTIONS).....	10
BACK PANEL CONTROLS - (FOR UNITS WITHOUT THE OT OR EO OPTIONS) .....	11
FIG. 4: BACK PANEL CONTROLS- (FOR UNITS WITH THE OT OR EO OPTIONS).....	12
BACK PANEL CONTROLS - (FOR UNITS WITH THE OT OR EO OPTION) .....	13
POWER SUPPLY AND FUSE REPLACEMENT .....	14
PERFORMANCE CHECK SHEET .....	16

**FIG. 1: PULSE GENERATOR TEST ARRANGEMENT**

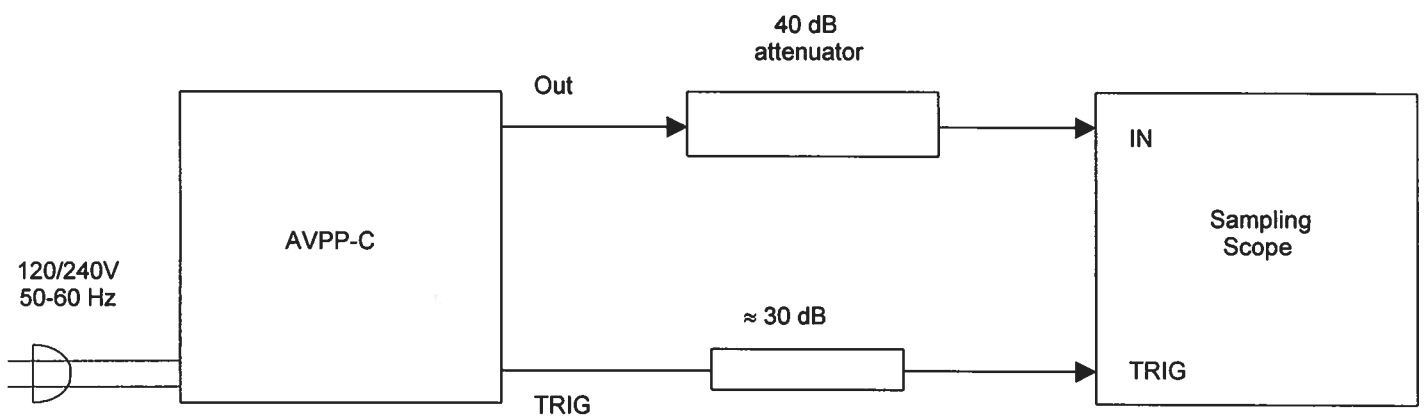

## GENERAL OPERATING INSTRUCTIONS

- 1) The bandwidth capability of components and instruments used to display the pulse generator output signal (attenuators, cables, connectors, etc.) should exceed ten gigahertz.
- 2) The use of 40 dB attenuator at the sampling scope vertical input channel will insure a peak input signal to the sampling scope of less than one Volt.
- 3) The AVPP-C contains two independent pulse generators which cover the output PW range of 0.2 to 8.0 ns (A) and 8.0 ns to 100 ns (B). A and B share a common internal clock and PW and AMP controls.
- 4) The TRIG output channel provides TTL level signals. To avoid overdriving the TRIG input channel of some sampling scopes, a 30 dB attenuator should be placed at the input to the sampling scope trigger channel.
- 5) To obtain a stable output display the PRF control on the front panel should be set mid-range while the PRF range switch may be in either range. The front panel TRIG toggle switch should be in the INT position. The front panel DELAY controls and the scope triggering controls are then adjusted to obtain a stable output. The scope may then be used to set the desired PRF by rotating the PRF control and by means of the PRF range switch.
- 6) The output pulse width is controlled by means of the front panel one turn PW control. The control should initially be set maximum clockwise and the pulse width adjusted using an oscilloscope.
- 7) The output pulse amplitude is controlled by means of the front panel one turn AMP control. The pulse width may change by several nanoseconds as the output amplitude is reduced from maximum to minimum. Therefore it is convenient to first set the desired amplitude and then set the desired pulse width. Rotation of the PW pot causes the position of the falling edge of the pulse to change.
- 8) Some properties of the output pulse may change as a function of the amplitude pot setting. For some demanding applications, it may be desirable to use a combination of external attenuators and the amplitude pot to achieve the desired output amplitude.

- 9) To DC offset the output pulse connect a DC power supply set to required DC offset value to the back panel terminals marked O.S. The maximum attainable DC offset voltage is  $\pm 50$  Volts (for non OT or EO option units only).
- 10) For units with the OT offset option, the output DC offset level is varied from -5 to +5V (to 50 ohm) by the front panel OFFSET one turn control. The DC offset may be turned off using the rear panel OS ON-OFF toggle switch. (OT option).
- 11) For units with the EO option, the output offset may be voltage controlled by setting the rear panel OS switch in the EXT position and applying 0 to +10 Volts to BNC connector "A" ( $R_{IN} \geq 10K$ ).
- 12) An external clock may be used to control the output PRF of the AVPP unit by setting the front panel TRIG toggle switch in the EXT position and applying a 0.2 us (approx.) TTL level pulse to the TRIG BNC connector input.
- 13) The monitor output (-M) provides a 20 dB attenuated coincident replica of the main output. (option).
- 14) To voltage control the output pulse width, set the rear panel PW switch in the EXT position and apply 0 to +10V to BNC connector A ( $R_{IN} \geq 10K$ ). (EW option).
- 15) To voltage control the output amplitude, set the rear panel Amp switch in the EXT position and apply 0 to +10V to BNC connector A ( $R_{IN} \geq 10K$ ). (EA option).
- 16) Dual Polarity Option (for units without the OT or EO options).

RANGE A: Use AVX-2-T; RANGE B: Use AVX-3-T.

To invert the output of the AVPP unit, connect the AVX-2-T (or AVX-3-T) unit to the OUT port. An inverted pulse is then obtained at the OUT port of the AVX-2-T (or AVX-3-T) unit. To offset the inverted pulse, apply the required DC level to the DC terminal of the AVX-2-T unit (or AVX-3-T).

17) Dual Polarity Option (for units with the OT or EO options).

RANGE A: Use AVX-2-T; RANGE B: Use AVX-3-T.

To invert the output of the AVPP unit, connect the AVX-2-T (or AVX-3-T) unit to the OUT port. An inverted pulse is then obtained at the OUT port of the AVX-2-T (or AVX-3-T) unit. To offset the inverted pulse, connect a lead from the rear panel OS OUT BNC connector to the DC terminal of the AVX-2-T (or AVX-3-T) unit. The DC offset at the output of the AVX-2-T (or AVX-3-T) unit is then controlled by the front panel OFFSET control.

18) The AVPP-C unit can be converted from 120 to 240V 50-60 Hz operation by adjusting the voltage selector card in the rear panel fused voltage selector-cable connector assembly.

19) For additional assistance:

Tel: (613) 226-5772  
Fax: (613) 226-2802  
Email: [info@avtechpulse.com](mailto:info@avtechpulse.com)

FIG. 2: FRONT PANEL CONTROLS

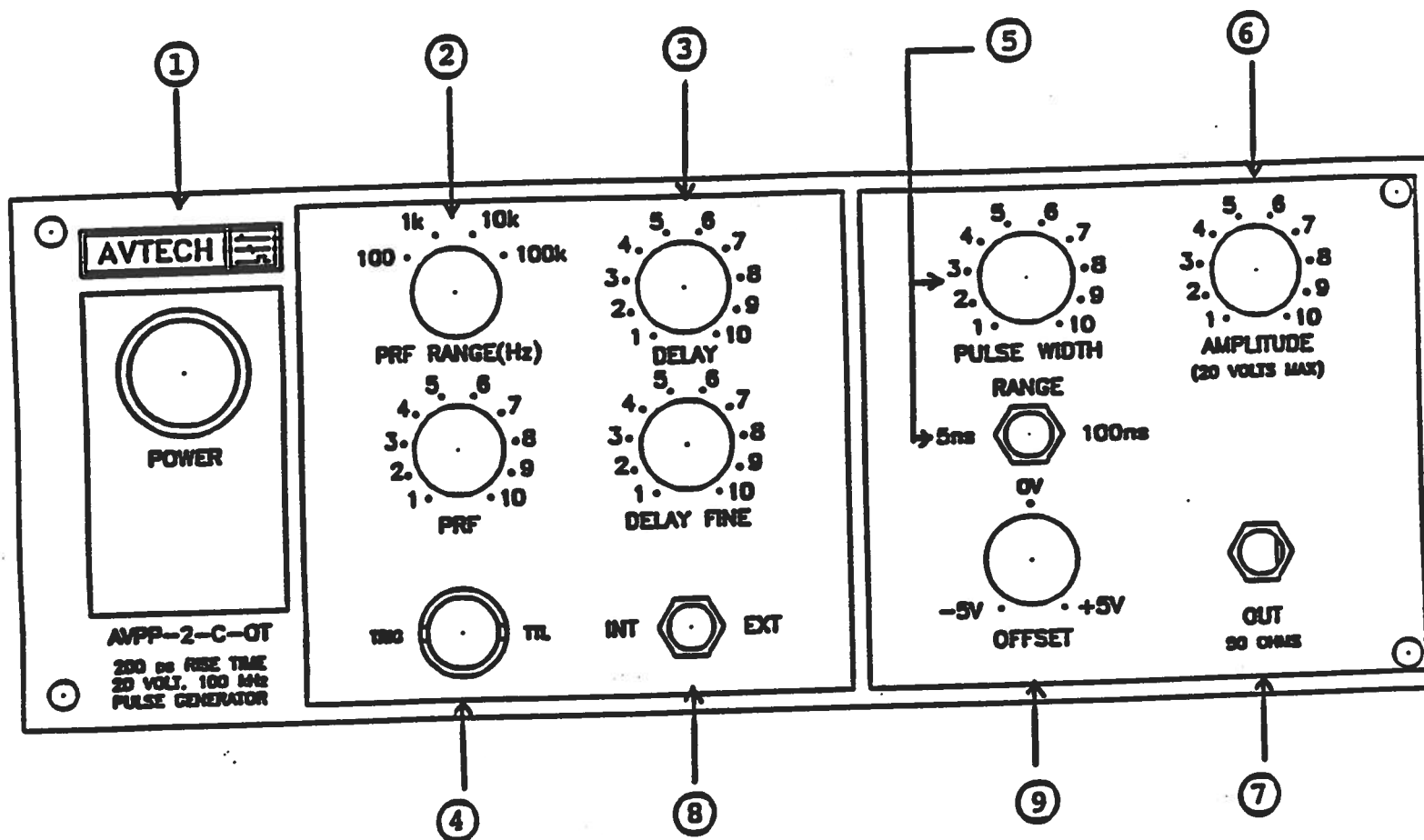



## FRONT PANEL CONTROLS

- 1) ON-OFF Switch. Applies basic prime power to all stages.
- 2) PRF Control. The PRF RANGE and PRF controls determine output PRF as follows:

	PRF MIN	PRF MAX
Range 1	10 Hz	100 Hz
Range 2	100 Hz	1 kHz
Range 3	1 kHz	10 kHz
Range 4	10 kHz	100 kHz

- 3) DELAY Controls. Controls the relative delay between the reference output pulse provided at the TRIG output (4) and the main output (7). This delay is variable over the range of 0 to at least 500 ns.
- 4) TRIG Output. This output precedes the main output (7) and is used to trigger the sampling scope time base. The output is a TTL level 100 ns (approx.) pulse capable of driving a fifty Ohm load. The external trigger signal is applied at this input when the EXT-INT toggle switch is in the EXT position.
- 5) PW Control. A one turn control and two-position range switch which varies the output pulse width as follows:
 

Range A:	0.2 ns to	8 ns
Range B:	8 ns to	100 ns
- 6) AMP Control. A one turn control which varies the output pulse amplitude.
- 7) OUT. SMA connector provides output to 50 Ohm load.
- 8) EXT-INT Control. With this toggle switch in the INT position, the PRF of the AVPP unit is controlled via an internal clock which in turn is controlled by the PRF controls. With the toggle switch in the EXT position, the AVPP unit requires a 0.2 us TTL level pulse applied at the TRIG input in order to trigger the output stages. In addition, in this mode, the scope time base must be triggered by the external trigger source.
- 9) OFFSET. The DC offset on the output can be varied from 0 to  $\pm 5$  Volts via this one turn control. The offset may be turned on or off using the rear panel two position OS ON-OFF switch. (option).

**FIG. 3: BACK PANEL CONTROLS - (FOR UNITS WITHOUT THE OT OR EO OPTIONS)**

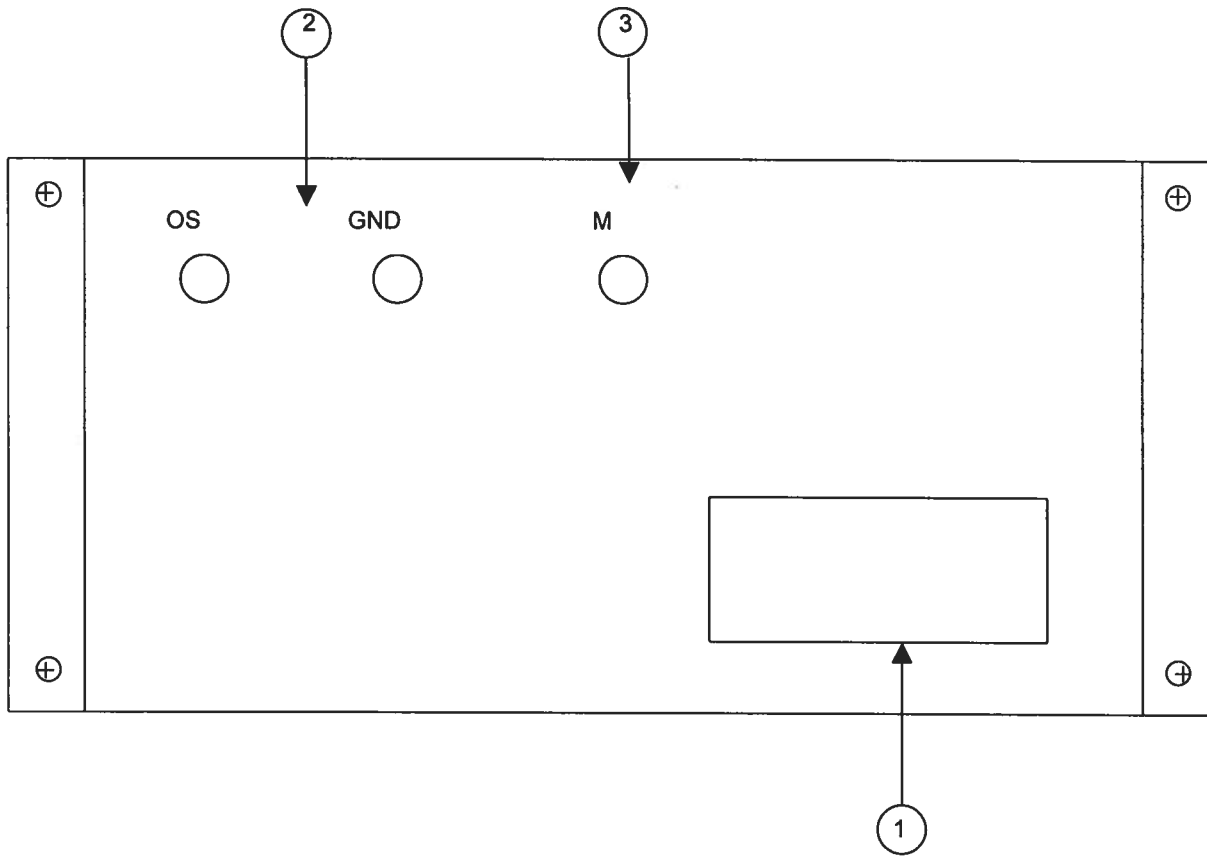

BACK PANEL CONTROLS - (FOR UNITS WITHOUT THE OT OR EO OPTIONS)

- 1) FUSED CONNECTOR, VOLTAGE SELECTOR. The detachable power cord is connected at this point. In addition, the removable cord is adjusted to select the desired input operating voltage. The unit also contains the main power fuse (0.5 A SB).
- 2) DC OFFSET Input. To DC offset the output pulse, connect a DC power supply set to the desired offset value to these terminals. The maximum allowable DC offset voltage is  $\pm 50$  Volts.
- 3) MONITOR OUT M. Provides an attenuated (x10) coincident replica of the main positive output pulse to fifty Ohms. (option).

**FIG. 4: BACK PANEL CONTROLS- (FOR UNITS WITH THE OT OR EO OPTIONS)**

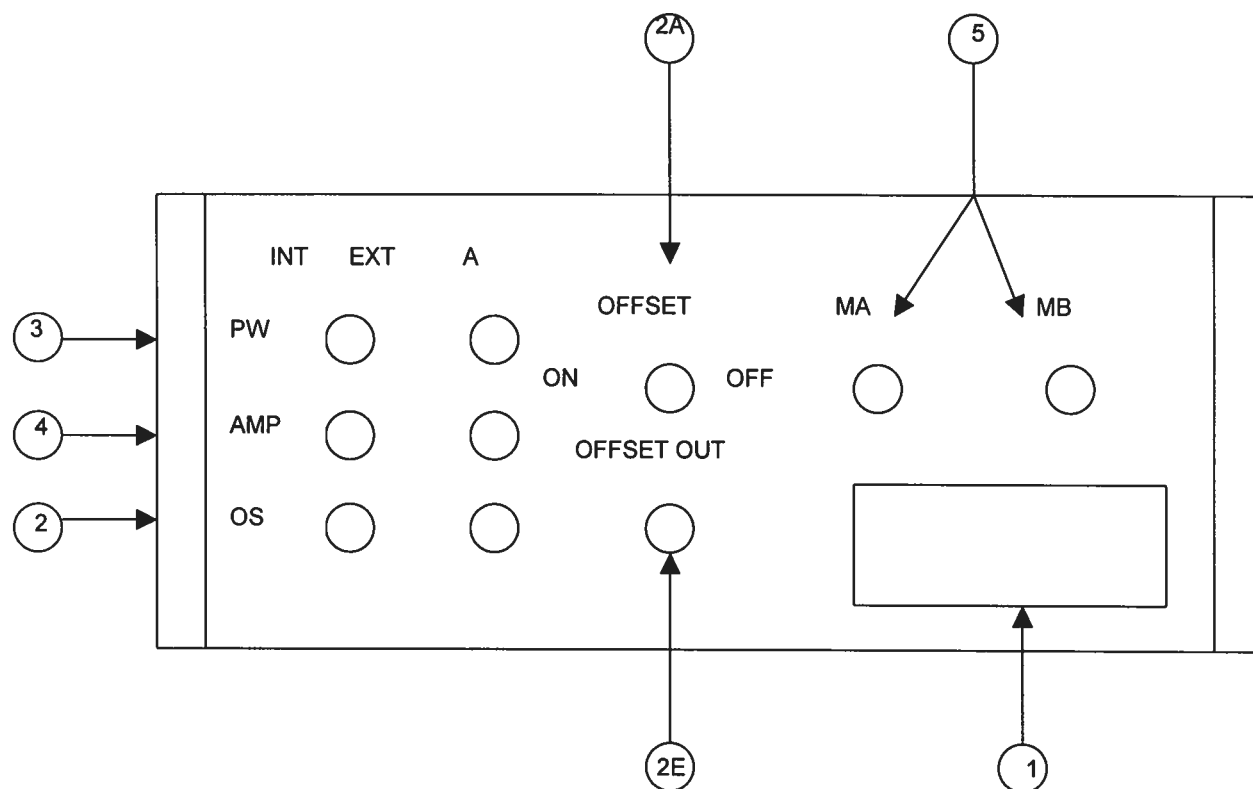

**BACK PANEL CONTROLS - (FOR UNITS WITH THE OT OR EO OPTION)**

- 1) **FUSED CONNECTOR, VOLTAGE SELECTOR.** The detachable power cord is connected at this point. In addition, the removable cord is adjusted to select the desired input operating voltage. The unit also contains the main power fuse (0.5 A SB).
- 2) To voltage control the output DC offset, set the switch in the EXT position and apply 0 to +10 Volts to BNC connector A ( $R_{IN} \geq 10K$ ). (EO option).
- 2A) Two position switch which turns output DC offset ON or OFF. (EO or OT options).
- 2B) With OFFSET ON-OFF switch in ON position, DC output offset potential appears at this terminal. To offset inverted pulse on AVPP units with dual polarity option (-PN) connect this terminal to the DC terminal of the AVX-2-T-OT module. (EO or OT options).
- 3) To voltage control the output pulse width, set the switch in the EXT position and apply 0 to +10V to BNC connector A ( $R_{IN} \geq 10K$ ). (EW option).
- 4) To voltage control the output amplitude, set the switch in the EXT position and apply 0 to +10V to BNC connector A ( $R_{IN} \geq 10K$ ). (EA option).
- 5) **MONITOR Output.** Provides an attenuated (x10) coincident replica (to 50 Ohms) of the main output. (option).

## POWER SUPPLY AND FUSE REPLACEMENT

This instrument has three fuses (plus one spare). One, which protects the AC input, is located in the rear-panel power entry module, as described in the “Rear Panel Controls” section of this manual. If the power appears to have failed, check the AC fuse first.

The other two fuses (plus one spare) are located on the internal DC power supply, as shown below:

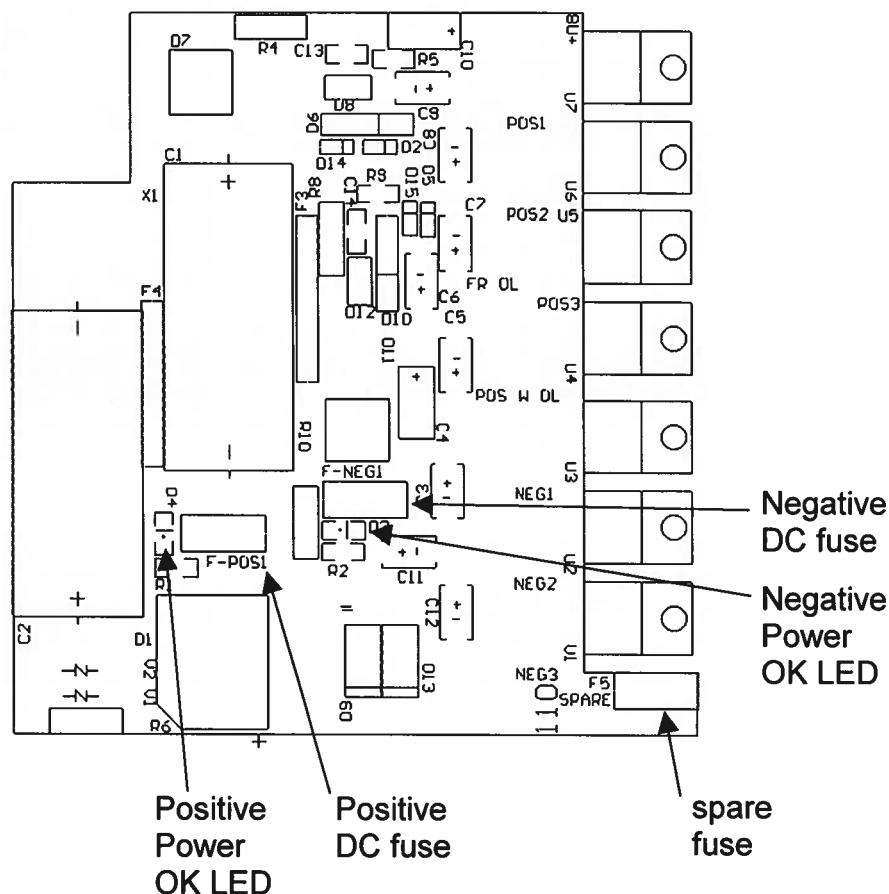

The spare fuse may be used to replace one of the other fuses, if required.

The three fuses on this circuit board are 0.5A slow-blow fuses, Littlefuse part number R452.500. (This fuse can be ordered from Digikey, [www.digikey.com](http://www.digikey.com). The Digikey part number is F1341CT-ND).

If you suspect that the DC fuses are blown, follow this procedure:

1. Remove the top cover, by removing the four Phillips screws on the top cover and then sliding the cover back and off.
2. Locate the two "Power OK" LEDs on the power supply circuit board, as illustrated above.
3. Turn on the instrument.
4. Observe the "Power OK" LEDs. If the fuses are not blown, the two LEDs will be lit (bright red). If one of the LEDs is not lit, the fuse next to it has blown.
5. Turn off the instrument.
6. If a fuse is blown, use needle-nose pliers to remove the blown fuse from its surface-mount holder.
7. Replace the fuse.