



AVTECH ELECTROSYSTEMS LTD.

NANOSECOND WAVEFORM ELECTRONICS
SINCE 1975

□ P.O. BOX 265
OGDENSBURG, NY
U.S.A. 13669-0265
TEL: (315) 472-5270
FAX: (613) 226-2802

TEL: 1-800-265-6681
FAX: 1-800-561-1970

e-mail: info@avtechpulse.com
<http://www.avtechpulse.com>

□ P.O. BOX 5120 STN. F
OTTAWA, ONTARIO
CANADA K2C 3H4
TEL: (613) 226-5772
FAX: (613) 226-2802

INSTRUCTIONS

MODEL AVR-1-PW-PS PULSE GENERATOR

S.N.:

WARRANTY

Avtech Electrosystems Ltd. warrants products of its manufacture to be free from defects in material and workmanship under conditions of normal use. If, within one year after delivery to the original owner, and after prepaid return by the original owner, this Avtech product is found to be defective, Avtech shall at its option repair or replace said defective item. This warranty does not apply to units which have been disassembled, modified or subjected to conditions exceeding the applicable specifications or ratings. This warranty is the extent of the obligation assumed by Avtech with respect to this product and no other warranty or guarantee is either expressed or implied.

TECHNICAL SUPPORT

Phone: 613-226-5772 or 1-800-265-6681

Fax: 613-226-2802 or 1-800-561-1970

E-mail: info@avtechpulse.com

World Wide Web: <http://www.avtechpulse.com>

TABLE OF CONTENTS

WARRANTY.....	2
TABLE OF CONTENTS	3
FIG. 1: PULSE GENERATOR TEST ARRANGEMENT.....	4
GENERAL OPERATING INSTRUCTIONS.....	5
FIG. 2: FRONT PANEL CONTROL.....	7
FRONT PANEL CONTROLS	8
FIG. 3: BACK PANEL CONTROLS.....	9
BACK PANEL CONTROLS.....	10
FIG. 4: SYSTEM DESCRIPTION AND REPAIR PROCEDURE	11
SYSTEM BLOCK DIAGRAM AND REPAIR PROCEDURE.....	12
PERFORMANCE CHECK SHEET	13

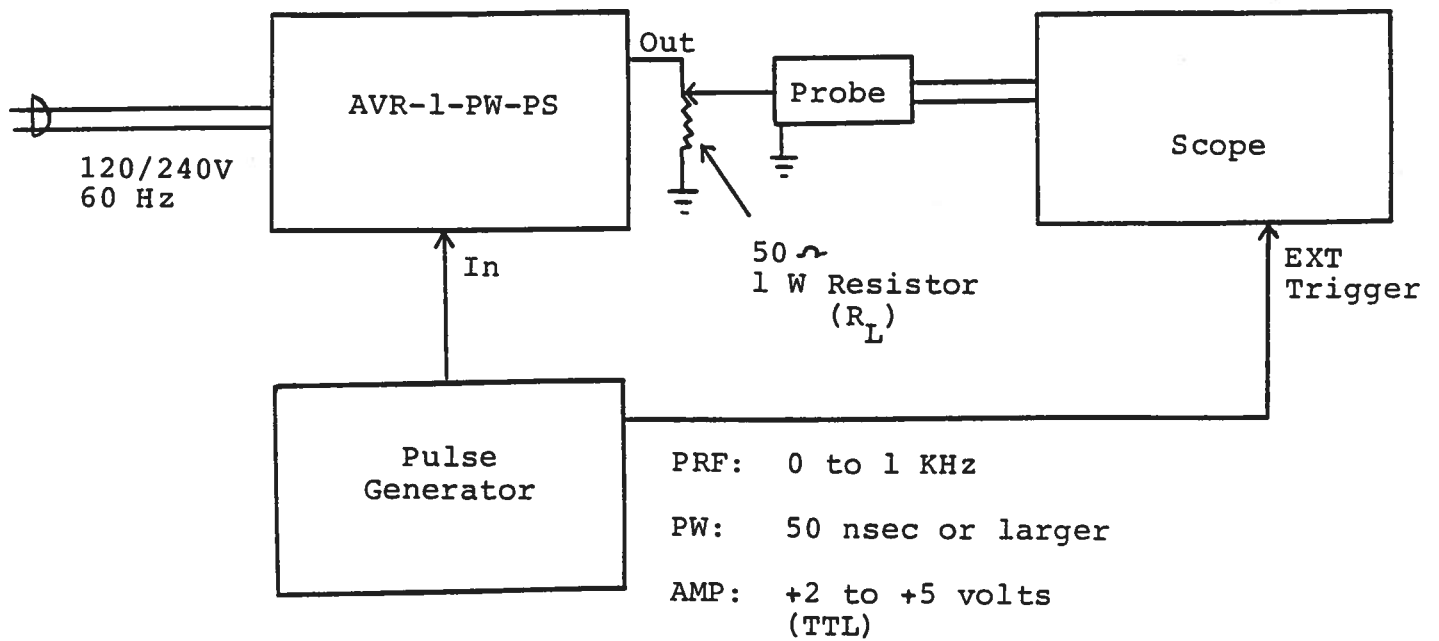
FIG. 1: PULSE GENERATOR TEST ARRANGEMENT

GENERAL OPERATING INSTRUCTIONS

- 1) The bandwidth capability of components and instruments used to display the pulse generator output signal (attenuators, cables, connectors, etc.) should exceed 100 MHz.
- 2) The use of 60 dB attenuator at the scope vertical input channel will insure a peak input signal to the scope of less than one Volt (necessary only if sampling scope used). If a high impedance real time scope is used, the pulse generator should be terminated using a shunt 50 Ohm resistor.
- 3) The output pulse width is controlled by means of the front panel PW control and the two-position range switch as follows.

50 to 500 ns
0.5 to 5.0 us
- 4) To voltage control the output pulse width, set the rear panel switch in the EXT position and apply 0 to +10V to BNC connector "A" ($R_{IN} \geq 10K$). Note that due to the digital nature of the EW option, some pulse width jitter may be observed at certain settings of the PW pot. This jitter may be removed by setting the rear panel PW LOCK switch in the ON position. When in the ON position, the pulse becomes frozen and will not change (as the PW pot is adjusted) until the switch is placed in the OFF position. (option)
- 5) The output pulse amplitude is controlled by means of the front panel one turn AMP control. To voltage control the output, set the rear panel switch in the EXT position and apply 0 to +10 Volts to BNC connector "A" ($R_{IN} \geq 10K$). (option)
- 6) The AVR features an output impedance of the order of several Ohms (rather than 50 Ohms). The following consequences of this feature should be noted:
 - a) When used to switch some semiconductor devices (e.g. bipolar and VMOS power transistors), the AVR unit will yield much faster switching times than those provided by 50 Ohm pulse generators.
 - b) The AVR unit will safely operate in to load impedances in the range of 50 Ohms to an open circuit. However, the fall time may degrade for load impedances higher than fifty Ohms.

- c) The AVR unit may be effectively converted to a fifty Ohm output impedance generator by placing a fifty Ohm 1/2 watt carbon composition resistor in series with the output of the unit and the load. The maximum available load voltage will then decrease to 100 Volts (from 200 Volts).
 - d) The output switching elements may fail if the unit is inadvertently operated into a short circuit. The switching elements are easily replaced in the field following the procedure outlined in the REPAIR Section.
- 7) Units with a serial number higher than 5600 are protected by an automatic overload protective circuit which controls the front panel overload light. If the unit is overloaded (by operating at an exceedingly high duty cycle or by operating into a short circuit), the protective circuit will turn the output of the instrument OFF and turn the indicator light ON. The light will stay ON (i.e. output OFF) for about 5 seconds after which the instrument will attempt to turn ON (i.e. light OFF) for about 1 second. If the overload condition persists, the instrument will turn OFF again (i.e. light ON) for another 5 seconds. If the overload condition has been removed, the instrument will turn on and resume normal operation. Overload conditions may be removed by:
- 1) Reducing PRF (i.e. switch to a lower range)
 - 2) Reducing pulse width (i.e. switch to a lower range)
 - 3) Removing output load short circuit (if any)
- 8) The unit can be converted from 120 to 240 50-60 Hz operation by adjusting the voltage selector card in the rear panel fused voltage selector-cable connector assembly.
- 9) For additional assistance:
- Tel: 613-226-5772
Fax: 613-226-2802

FIG. 2: FRONT PANEL CONTROL

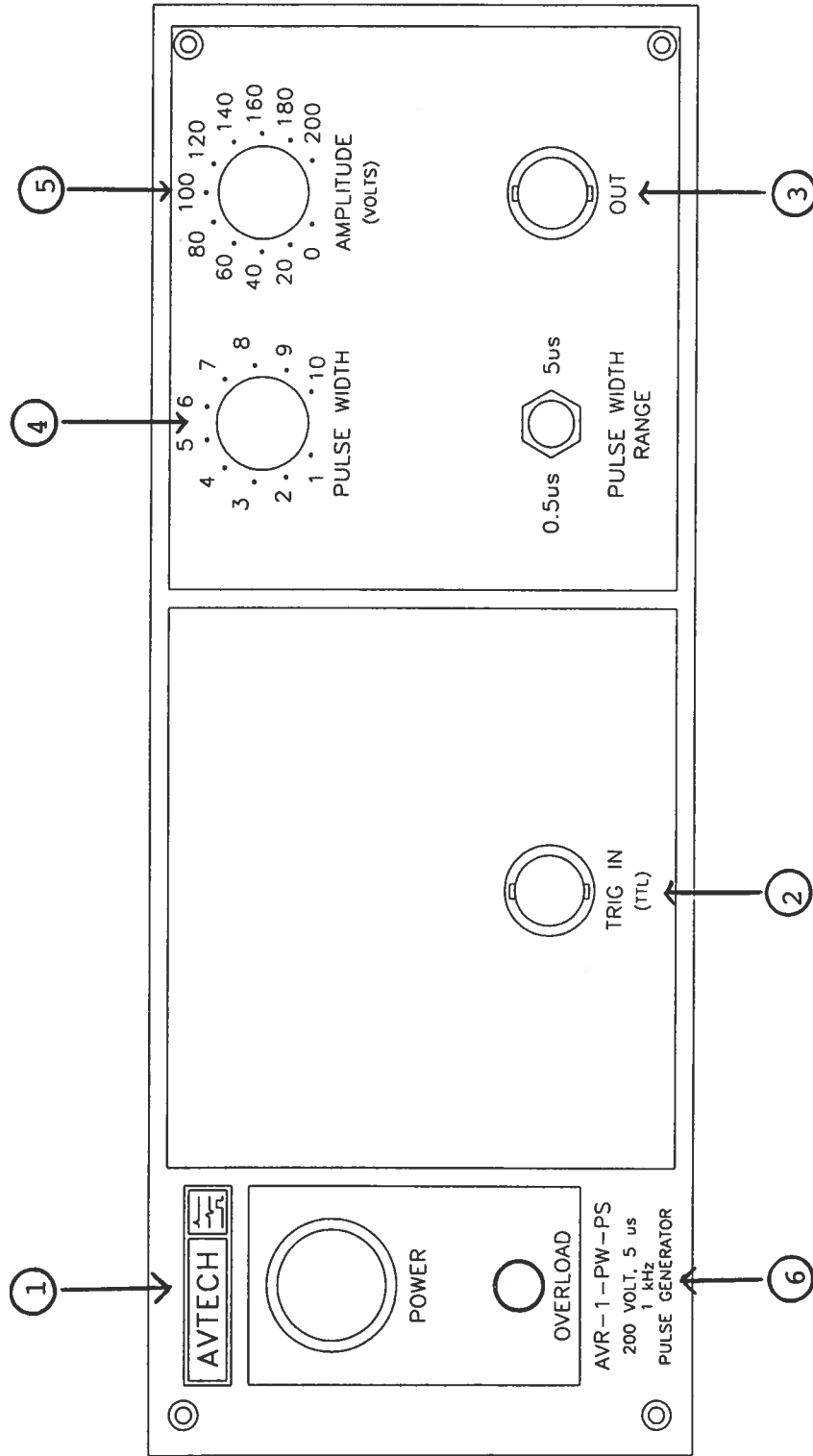

FRONT PANEL CONTROLS

- 1) ON-OFF Switch. Applies basic prime power to all stages.
- 2) The AVR unit requires a 50 ns (or wider) TTL level pulse applied at the TRIG input in order to trigger the output stages.
- 3) OUT Connector. BNC connector provides output to a fifty Ohm load (or higher).
- 4) PW Control. A one turn control which varies the output pulse width from 50 ns to 5 us (50 ns to 0.5 us and 0.5 us to 5.0 us).
- 5) AMP Control. A one turn control which varies the output pulse amplitude from 0 to 200V to a fifty Ohm load.
- 6) Units with a serial number higher than 5600 are protected by an automatic overload protective circuit which controls the front panel overload light. If the unit is overloaded (by operating at an exceedingly high duty cycle or by operating into a short circuit), the protective circuit will turn the output of the instrument OFF and turn the indicator light ON. The light will stay ON (i.e. output OFF) for about 5 seconds after which the instrument will attempt to turn ON (i.e. light OFF) for about 1 second. If the overload condition persists, the instrument will turn OFF again (i.e. light ON) for another 5 seconds. If the overload condition has been removed, the instrument will turn on and resume normal operation. Overload conditions may be removed by:
 - 1) Reducing PRF (i.e. switch to a lower range)
 - 2) Reducing pulse width (i.e. switch to a lower range)
 - 3) Removing output load short circuit (if any)

FIG. 3: BACK PANEL CONTROLS

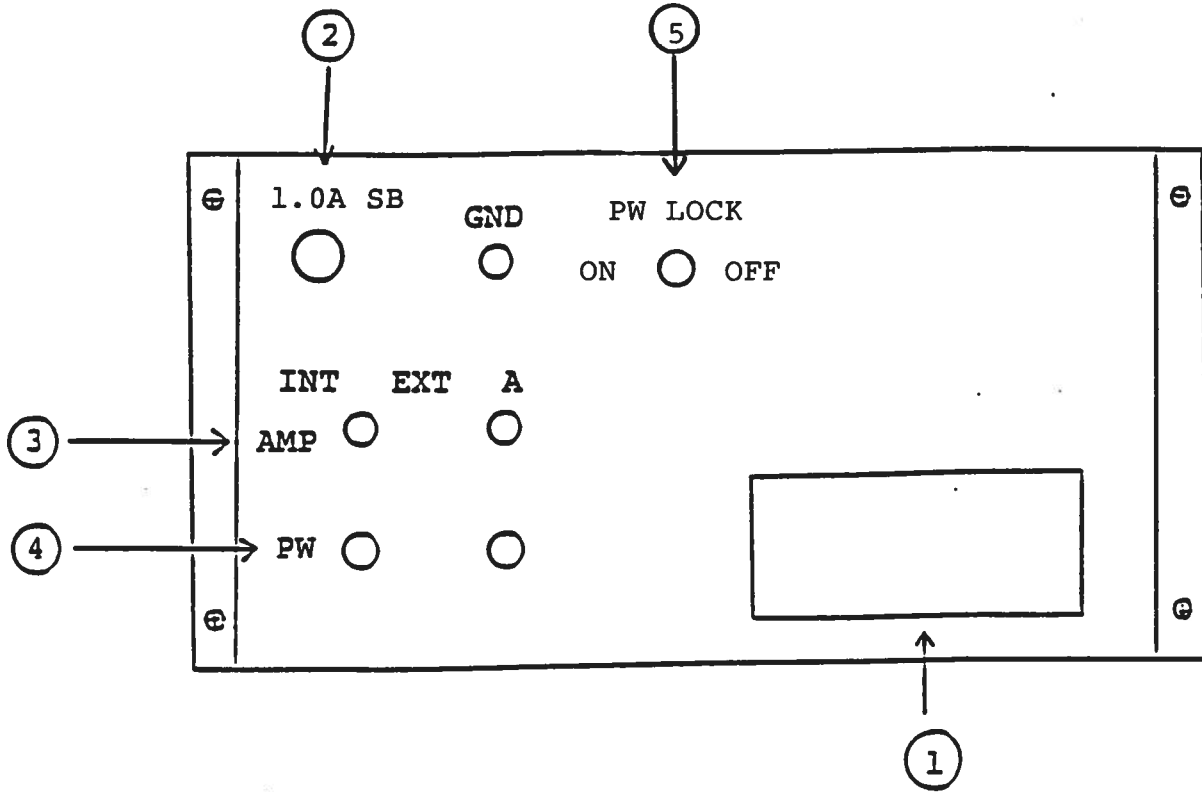

BACK PANEL CONTROLS

- 1) FUSED CONNECTOR, VOLTAGE SELECTOR. The detachable power cord is connected at this point. In addition, the removable cord is adjusted to select the desired input operating voltage. The unit also contains the main power fuse (0.5 A SB).
- 2) 1.0 A SB. Fuse which protects the output stage if the output duty cycle rating is exceeded.
- 3) EA. To voltage control the output amplitude, set the switch in the EXT position and apply 0 to +10 Volts to BNC connector A ($R_{IN} \geq 10K$). (option).
- 4) EW. To voltage control the output pulse width, set the switch in the EXT position and apply 0 to +10 Volts to BNC connector A ($R_{IN} \geq 10K$). (option).
- 5) PW LOCK: Due to the digital nature of the EW option, some pulse width jitter may be observed at certain settings of the PW pot. This jitter may be removed by setting the rear panel PW LOCK switch in the ON position. When in the ON position, the pulse becomes frozen and will not change (as the PW pot is adjusted) until the switch is placed in the OFF position. (option)

FIG. 4: SYSTEM DESCRIPTION AND REPAIR PROCEDURE

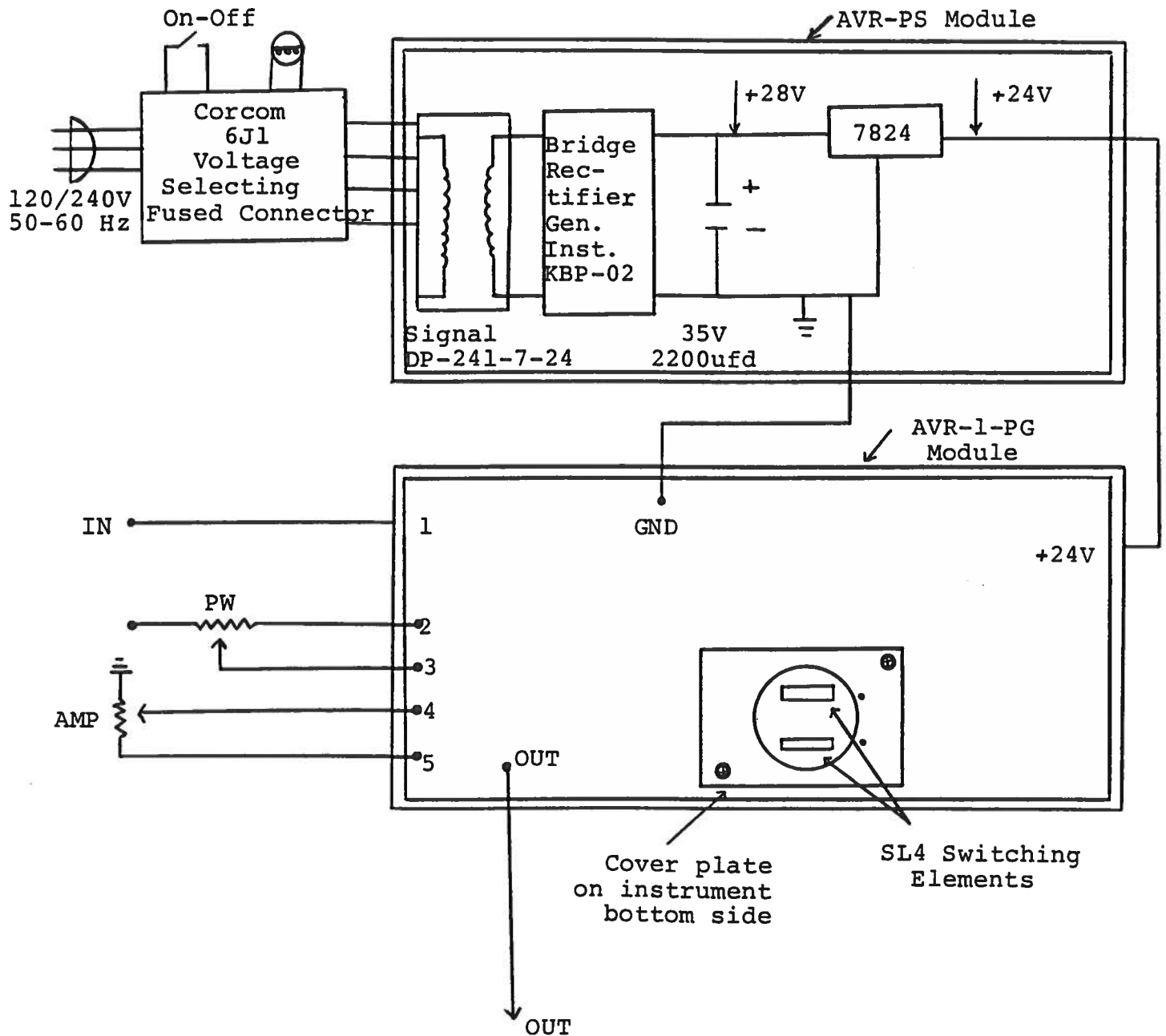

SYSTEM BLOCK DIAGRAM AND REPAIR PROCEDURE

The AVR-PS consists of the following basic modules:

- 1) AVR-PG pulse generator module
- 2) +24V power supply board

The modules are interconnected as shown in Fig. 4.

In the event of an instrument malfunction, it is most likely that the rear panel 1.0 SB fuse or some of the output switching elements (SL4) may have failed due to an output short circuit condition or to a high duty cycle condition. The switching elements may be accessed by removing the cover plate on the bottom side of the instrument. NOTE: First turn off the prime power. The elements may be removed from their sockets by mean of a needle-nosed pliers. The SL4 is a selected VMOS power transistor in a TO 220 packages and may be checked on a curve tracer. If defective, replacement units should be ordered directly from Avtech. When replacing the SL4 switching elements, take care to insure that the short lead (of the three leads) is adjacent to the black dot on the chassis. If the switching elements are not defective, then the four Phillips screws on the back panel should be removed. The top cover may then be slid off and operation of the power supply module should be checked. The power supply board generates +24V DC to power the other modules. If the voltage is less than +24V, turn off the prime power and unsolder the lead from the 7824 regulator chip on the power supply board. Solder a 100 Ohm 5 Watt resistor to the 7824 output to ground and turn on the prime power. A voltage of +24 Volts should be read. If the voltage is less then the power supply board is defective and should be repaired or replaced.

Feb 8/99

Edition C

aur/aur-1-pw-ps-edc.doc