

AVTECH ELECTROSYSTEMS LTD.

NANOSECOND WAVEFORM ELECTRONICS
ENGINEERING . MANUFACTURING

□ P.O. BOX 265
OGDENSBURG
NEW YORK
13669
(315) 472.5270

BOX 5120 STN. "F"
OTTAWA, ONTARIO
CANADA K2C 3H4
TELEX 053-4591
(613) 226-5772

INSTRUCTIONS

MODEL AVR-1-P-AS3 PULSE GENERATOR

S.N. :

WARRANTY

Avtech Electrosystems Ltd. warrants products of its manufacture to be free from defects in material and workmanship under conditions of normal use. If, within one year after delivery to the original owner, and after prepaid return by the original owner, this Avtech product is found to be defective, Avtech shall at its option repair or replace said defective item. This warranty does not apply to units which have been disassembled, modified or subjected to conditions exceeding the applicable specifications or ratings. This warranty is the extent of the obligation or liability assumed by Avtech with respect to this product and no other warranty or guarantee is either expressed or implied.

A.

TEST ARRANGEMENT

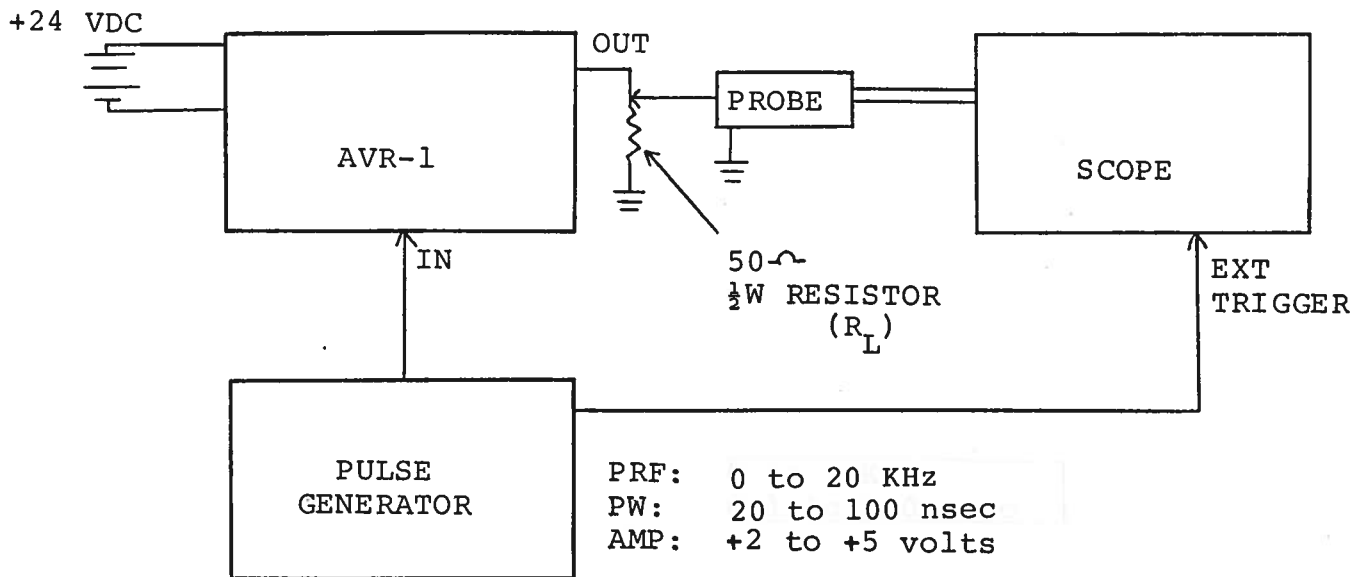

GENERAL OPERATING INSTRUCTIONS

- 1) The equipment should be connected in the general fashion shown above. Since the AVR unit provides an output pulse rise time as low as 10 nsec a fast oscilloscope (at least 50 MHz and preferably 200 MHz) should be used to display the waveform. Also, if a load of other than 50 ohm is employed, the length of coaxial cable between the AVR unit and the load should not exceed about 5 feet or the output waveform may be degraded by the resulting reflections.
- 2) The magnitude of the output pulse is controlled by the front panel one turn pot (AMP). Maximum clockwise rotation of the pot provides the maximum output.
- 3) The output pulse width and PRF are equal to the input trigger pulse values.
- 4) Care should be taken to not operate with an input pulse width greater than 200 nsec as prolonged operation in this mode may very well result in equipment failure. Also, the maximum PRF of 20 KHz must not be exceeded for the same reason. Under simultaneous conditions of wide pulse width, high PRF and high load current, the bias voltage applied to the output power stage decreases and as a result the attainable output peak voltage decreases to less than 200 volts, and in severe cases, the output stage of the unit may be damaged.
- 5) In the event of severe overloading, the output switching elements (Avtech Part No. SL9H) may fail. The SL9H units are readily replaced by removing the four screws which affix the small cover plate to the bottom of the AVR chassis. The SL9H units may then be extracted from their sockets using needle nose pliers. When replacing the SL9H units take care to ensure that the short lead is placed adjacent to the black dot on the AVR chassis.

