



AVTECH ELECTROSYSTEMS LTD.

NANOSECOND WAVEFORM ELECTRONICS
SINCE 1975

□ P.O. BOX 265
OGDENSBURG, NY
U.S.A. 13669-0265
TEL: (315) 472-5270
FAX: (613) 226-2802

TEL: 1-800-265-6681
FAX: 1-800-561-1970

e-mail: info@avtechpulse.com
<http://www.avtechpulse.com>

□ P.O. BOX 5120 STN. F
OTTAWA, ONTARIO
CANADA K2C 3H4
TEL: (613) 226-5772
FAX: (613) 226-2802

INSTRUCTIONS

MODEL AVR-3-PW-PS-PN PULSE GENERATOR

S.N.:

WARRANTY

Avtech Electrosystems Ltd. warrants products of its manufacture to be free from defects in material and workmanship under conditions of normal use. If, within one year after delivery to the original owner, and after prepaid return by the original owner, this Avtech product is found to be defective, Avtech shall at its option repair or replace said defective item. This warranty does not apply to units which have been disassembled, modified or subjected to conditions exceeding the applicable specifications or ratings. This warranty is the extent of the obligation assumed by Avtech with respect to this product and no other warranty or guarantee is either expressed or implied.

TECHNICAL SUPPORT

Phone: 613-226-5772 or 1-800-265-6681

Fax: 613-226-2802 or 1-800-561-1970

E-mail: info@avtechpulse.com

World Wide Web: <http://www.avtechpulse.com>

TABLE OF CONTENTS

WARRANTY.....	2
TABLE OF CONTENTS	3
FIG. 1: PULSE GENERATOR TEST ARRANGEMENT	4
GENERAL OPERATING INSTRUCTIONS	5
FIG. 2: FRONT PANEL CONTROLS	7
FRONT PANEL CONTROLS	8
FIG. 3: BACK PANEL CONTROLS.....	10
BACK PANEL CONTROLS.....	11
FIG. 3A: POWER SUPPLY.....	12
SYSTEM DESCRIPTION AND REPAIR PROCEDURE.....	14
PERFORMANCE CHECK SHEET	15

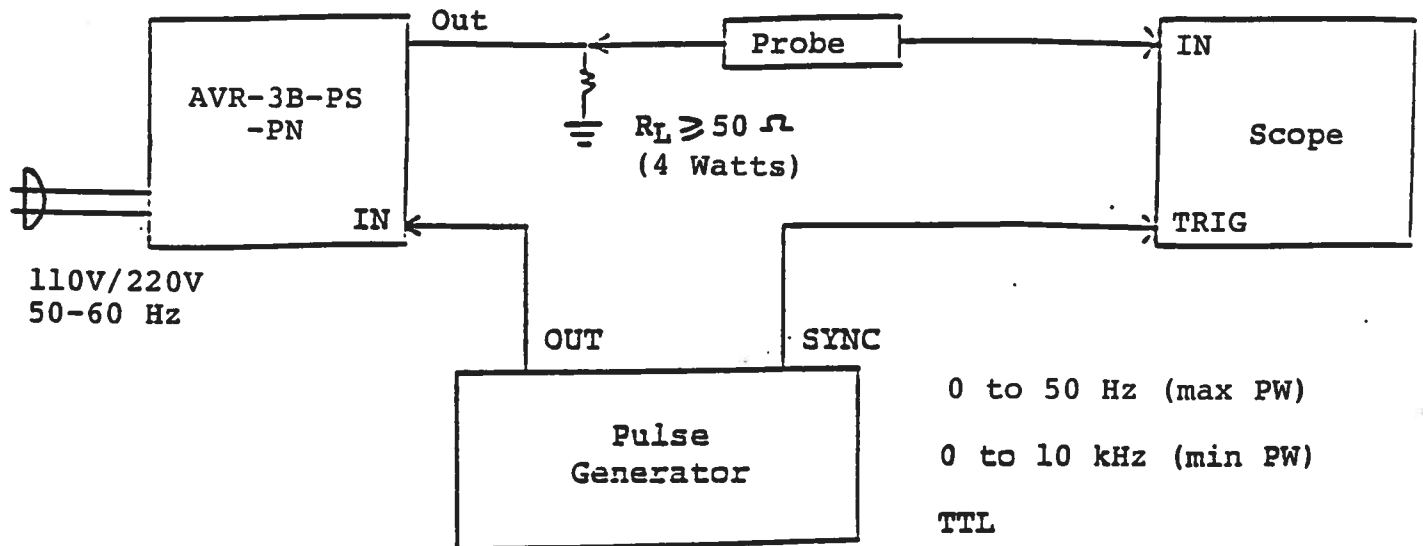
FIG. 1: PULSE GENERATOR TEST ARRANGEMENT

GENERAL OPERATING INSTRUCTIONS

- 1) The bandwidth capability of components and instruments used to display the pulse generator output signal (attenuators, cables, connectors, etc.) should exceed 100 MHz.
- 2) With the AB mode switch in the A position, the output pulse width is controlled by the 3 position PW range switch and the one turn PW control (10 turn control for units with the -PWT option). The minimum and maximum PW for each range and the corresponding maximum PRF are as follows. Note that the unit may fail if operated at duty cycles exceeding 0.5%.

	PW min	PW max
1)	0.1 us PRF max 10 kHz	1.0 us PRF max 5 kHz
2)	1.0 us PRF max 5 kHz	10 us PRF max 500 Hz
3)	10 us PRF max 500 Hz	100 us PRF max 50 Hz

- 3) With the AB mode switch in the B position, the output pulse width is equal to the input trigger pulse width.
- 4) The output pulse amplitude is controlled by means of the front panel one turn AMP control. To voltage control the output amplitude, set the rear panel switch in the EXT position and apply 0 to +10 Volts to connector A ($R_{IN} \geq 10K$). (-EA option).
- 5) The output polarity is controlled by the two-position polarity switch. Note that to avoid stressing the output stage the amplitude should be turned down to zero before changing the position of the polarity switch.
- 6) The AVR-3-PS features an output impedance of the order of several Ohms (rather than 50 Ohms). The following consequences of this feature should be noted:
 - a) When used to switch some semiconductor devices (eg. bipolar and VMOS power transistors), the AVR unit will yield much faster switching times than those provided by 50 Ohm pulse generators.

- b) The output switching elements may fail if the unit is inadvertently operated into a short circuit. The switching elements are easily replaced in the field following the procedure outlined in the REPAIR Section.
- 7) **CAUTION:** The output stage is protected against overload condition by a 1.0 A slow blow fuse on the main frame back panel. However, the output switching elements may fail if the unit is triggered at a PRF exceeding 10 kHz or at duty cycles resulting in an average output power in excess of 4 Watts. Heating and subsequent likely failure of the output stage is reduced if the following action is taken where possible:
- a) PRF is kept to a minimum, i.e. operate in a low PRF range when possible rather than in a high PRF range.
 - b) Keep the output PW to a minimum.
- 8) **OVERLOAD INDICATOR.** AVR-3 units with a serial number higher than 5600 are protected by an automatic overload protective circuit which controls the front panel overload light. If the unit is overloaded (by operating at an exceedingly high duty cycle or by operating into a short circuit), the protective circuit will turn the output of the instrument OFF and turn the indicator light ON. The light will stay ON (i.e. output OFF) for about 5 seconds after which the instrument will attempt to turn ON (i.e. light OFF) for about 1 second. If the overload condition persists, the instrument will turn OFF again (i.e. light ON) for another 5 seconds. If the overload condition has been removed, the instrument will turn on and resume normal operation. Overload conditions may be removed by:
- 1) Reducing PRF (i.e. switch to a lower range)
 - 2) Reducing pulse width (i.e. switch to a lower range)
 - 3) Removing output load short circuit (if any)
- Note that the overload light may illuminate when the prime power is first applied. The light will extinguish after a few seconds and the instrument will then function normally.
- Note that the output stage will safely withstand a short circuited load condition.
- 9) The unit can be converted from 110 to 220V 50-60 Hz operation by adjusting the voltage selector card in the rear panel fused voltage selector cable connector assembly.
- 10) For additional assistance:
Tel: (613) 226-5772
Fax: (613) 226-2802

FIG. 2: FRONT PANEL CONTROLS

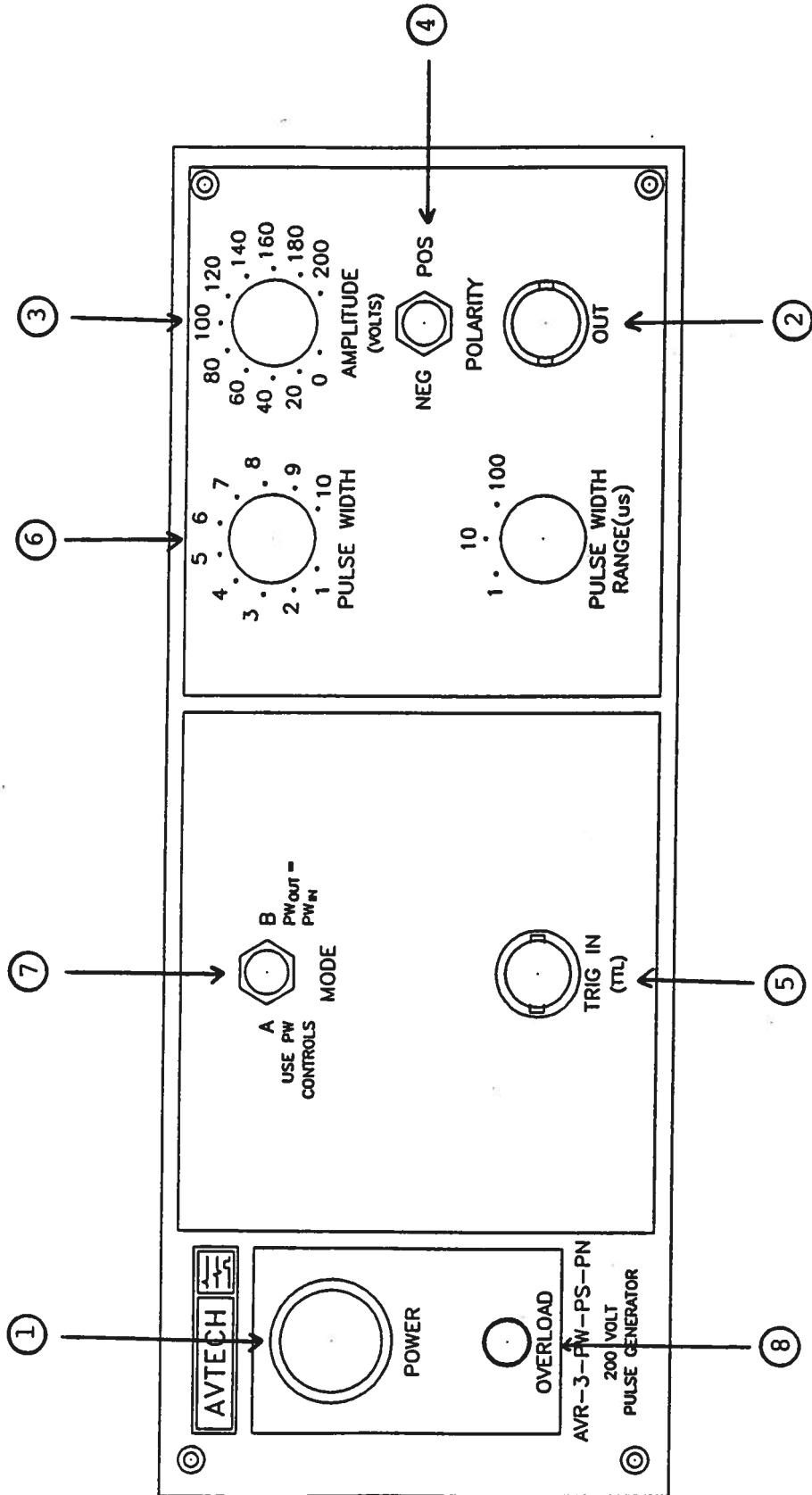

FRONT PANEL CONTROLS

- (1) ON-OFF Switch. Applies basic prime power to all stages.
- (2) OUT Connector. BNC connector provides output to the load ($R_L \geq 50 \text{ Ohm}$).
- (3) AMP Control. A one turn control which varies the output pulse amplitude from 0 to 200 V (ten turn control for -AT option units).
- (4) POLARITY. The output polarity is controlled by the two-position polarity switch. Note that to avoid stressing the output stage the amplitude should be turned down to zero before changing the position of the polarity switch.
- (5) TRIG Input. The external trigger signal is applied at this input (TTL).
- (6) PW Control. A one turn control (ten turn control for -PWT option units) and 3 position range switch which varies the output pulse width from 0.1 us to 100 us. The minimum and maximum PW for each range and the corresponding maximum PRF are as follows. Note that the unit may fail if operated at duty cycles exceeding 0.5%.

	PW min	PW max
Range 1	0.1 us PRF max 10 kHz	1.0 us PRF max 5 kHz
Range 2	1.0 us PRF max 5 kHz	10 us PRF max 500 Hz
Range 3	10 us PRF max 500 Hz	100 us PRF max 50 Hz

- (7) AB MODE. When switch is in the A position output pulse width is controlled by PW controls (6) while if switch is in the B position, the output pulse width equals the input trigger pulse width.
- (8) OVERLOAD INDICATOR. AVR-3 units with a serial number higher than 5600 are protected by an automatic overload protective circuit which controls the front panel overload light. If the unit is overloaded (by operating at an exceedingly high duty cycle or by operating into a short circuit), the protective circuit will turn the output of the instrument OFF and turn the indicator light ON. The light will stay ON (i.e. output OFF) for about 5 seconds after which the instrument will attempt to turn ON (i.e. light OFF) for about 1 second. If the overload condition persists, the instrument will turn OFF again (i.e. light ON) for another 5 seconds.

If the overload condition has been removed, the instrument will turn on and resume normal operation. Overload conditions may be removed by:

- 1) Reducing PRF (i.e. switch to a lower range)
- 2) Reducing pulse width (i.e. switch to a lower range)
- 3) Removing output load short circuit (if any)

Note that the overload light may illuminate when the prime power is first applied. The light will extinguish after a few seconds and the instrument will then function normally.

Note that the output stage will safely withstand a short circuited load condition.

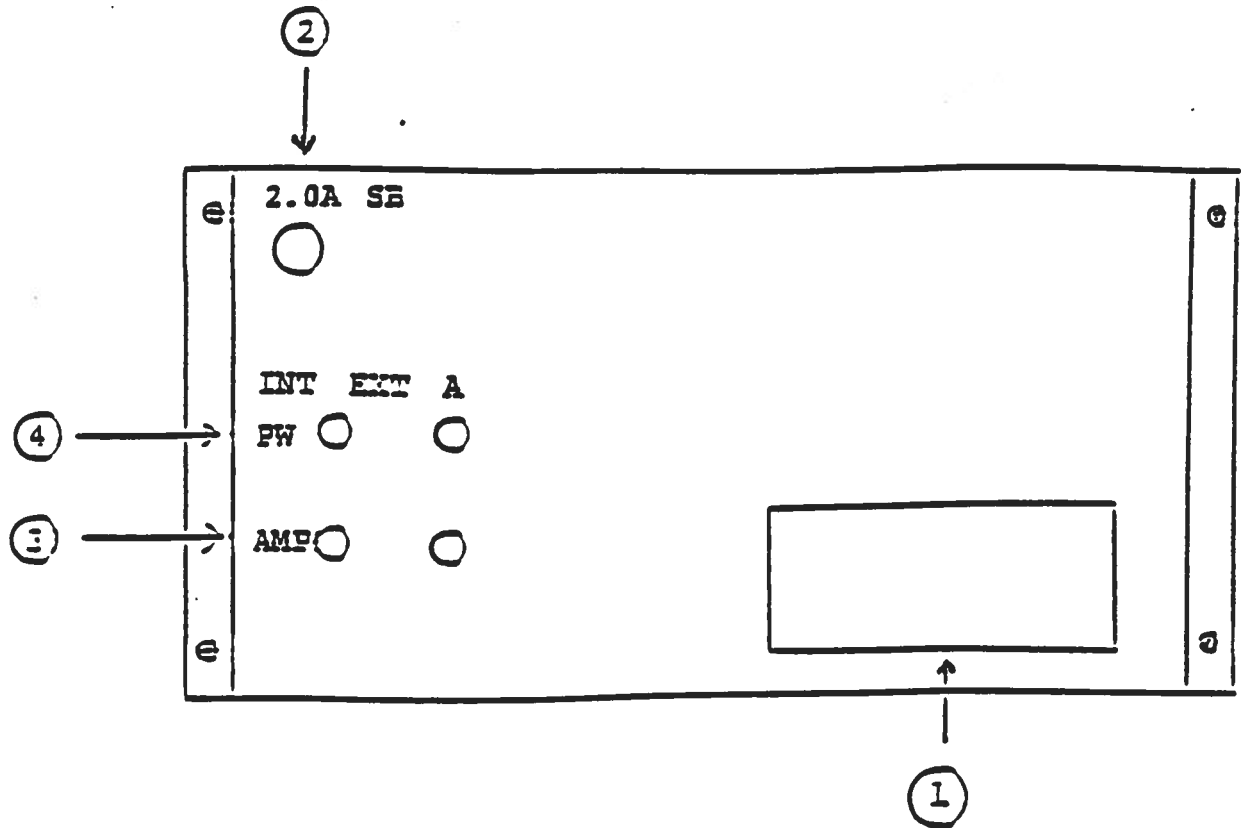
FIG. 3: BACK PANEL CONTROLS (EA, EW OPTION UNITS)

BACK PANEL CONTROLS

- (1) FUSED CONNECTOR, VOLTAGE SELECTOR. The detachable power cord is connected at this point. In addition, the removable cord is adjusted to select the desired input operating voltage. The unit also contains the main power fuse (1.0 A SB).
- (2) 1.0A SB. Fuse which protects the output stage if the output duty cycle rating is exceeded.
- (3) EA. To voltage control the output amplitude, set the switch in the EXT position and apply 0 to +10 Volts to connector A ($R_{IN} \geq 10K$). (option).
- (4) EW. To voltage control the output pulse width, set the switch in the EXT position and apply 0 to +10 Volts to connector A ($R_{IN} \geq 10K$). (option).

FIG. 3A: POWER SUPPLY

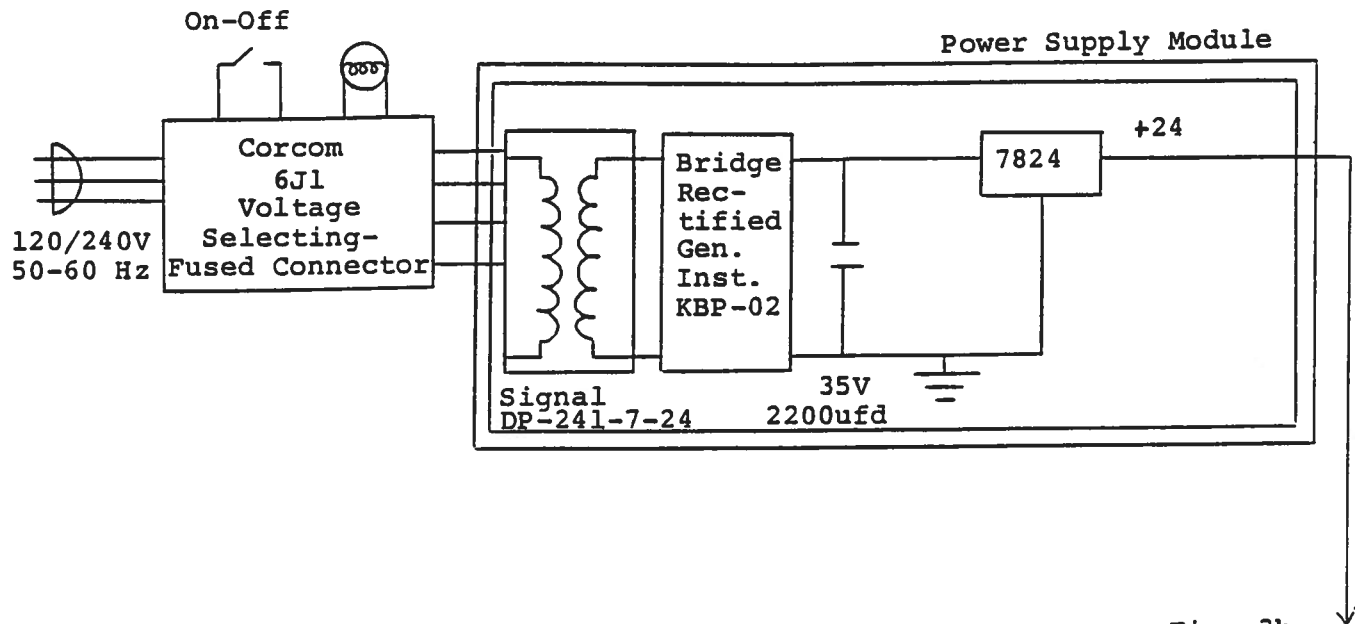
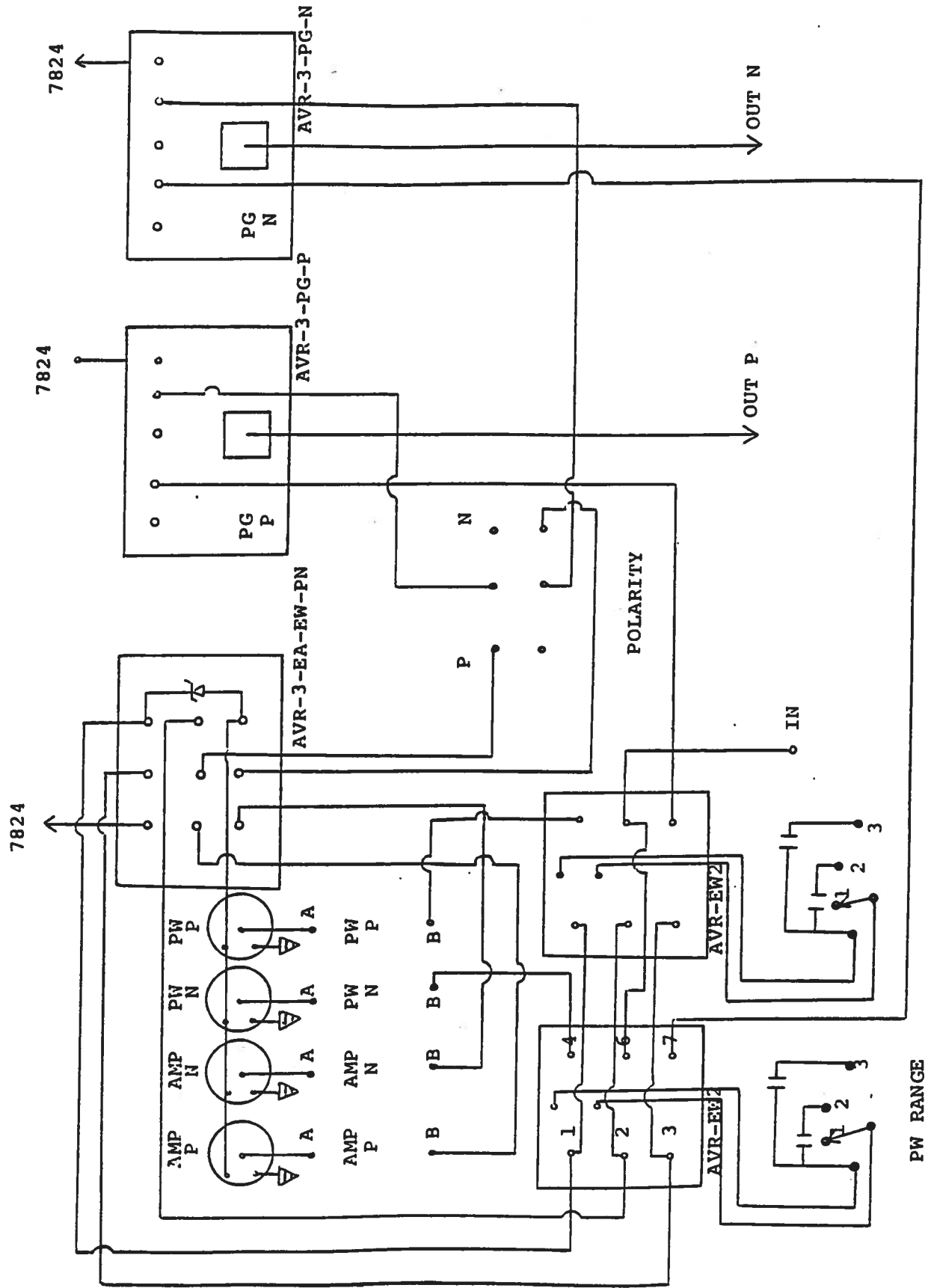

Fig. 3b



AVR-3-PW-PS-PN-EA-EW

PW RANGE

SYSTEM DESCRIPTION AND REPAIR PROCEDURE

The AVR-3-PW-PN consists of the following basic modules:

- 1) AVR-3-PW-PG pulse generator modules (-P and -N)
- 2) +24V power supply board
- 3) AVR-3-PS power supply modules (-P and -N)

In the event of an instrument malfunction, it is most likely that one of the rear panel fuses or some of the output switching elements (SL4T) may have failed due to an output short circuit condition or to a high duty cycle condition. The switching elements may be accessed by removing the cover plates on the bottom side of the instrument.

NOTE: First turn off the prime power. The elements may be removed from their sockets by means of a needle nosed pliers. The SL4T is a selected VMOS power transistor in a TO 220 packages and may be checked on a curve tracer. If defective, replacement units should be ordered directly from Avtech. When replacing the SL4T switching elements, take care to insure that the short lead (of the three leads) is adjacent to the black dot on the chassis.

PERFORMANCE CHECK SHEET

June 17/96

Edition B

-PWT

instructword\avr-3\avr-3-PW-PS-PN.doc

-EA

Word '97

-EW