

AVTECH ELECTROSYSTEMS LTD.

NANOSECOND WAVEFORM ELECTRONICS
ENGINEERING . MANUFACTURING

□ P.O. BOX 265
OGDENSBURG
NEW YORK
13669
(315) 472-5270

✠ BOX 5120 STN. "F"
OTTAWA, ONTARIO
CANADA K2C 3H4
(613) 226-5772
TELEX 053-4591

INSTRUCTIONS

MODEL AVR-3-PW-C PULSE GENERATOR

S.N.: 4093 MOD MAY 1988

WARRANTY

Avtech Electrosystems Ltd. warrants products of its manufacture to be free from defects in material and workmanship under conditions of normal use. If, within one year after delivery to the original owner, and after prepaid return by the original owner, this Avtech product is found to be defective, Avtech shall at its option repair or replace said defective item. This warranty does not apply to units which have been disassembled, modified or subjected to conditions exceeding the applicable specifications or ratings. This warranty is the extent of the obligation or liability assumed by Avtech with respect to this product and no other warranty or guarantee is either expressed or implied.

Fig. 1

PULSE GENERATOR TEST ARRANGEMENT

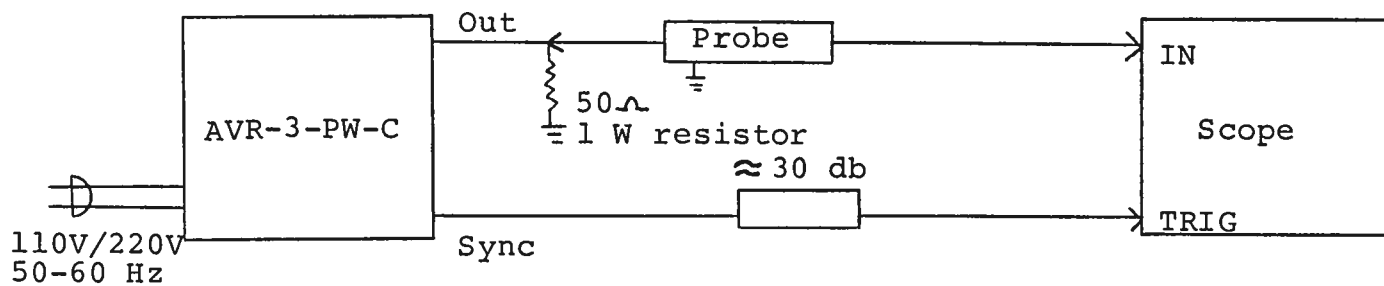

GENERAL OPERATING INSTRUCTIONS

- 1) The equipment should be connected in the general fashion shown above. Since the AVR unit provides an output pulse rise time as low as 10 nsec a fast oscilloscope (at least 50 MHz and preferably 200 MHz) should be used to display the waveform. Also, if a load of other than 50 ohm is employed, the length of coaxial cable between the AVR unit and the load should not exceed about 5 feet or the output waveform may be degraded by the resulting reflections.
- 2) The sync output channel provides TTL level signals. To avoid overdriving the TRIG input channel of some scopes, a 30 db attenuator should be placed at the input to the scope trigger channel.
- 3) The output pulse width is controlled by means of the front panel one turn PW and by the PW RANGE control. The minimum and maximum PW for each range and the corresponding maximum PRF are as follows. Note that the unit may fail if operated at duty cycles exceeding the above.

	PW min	PW max
Range 1	0.1 usec PRF max 1 KHz	1.0 usec PRF max 1 KHz
Range 2	1.0 usec PRF max 1 KHz	10 usec PRF max 500 Hz
Range 3	10 usec PRF max 500 Hz	100 usec PRF max 50 Hz

- 4) To obtain a stable output display the PRF control on the front panel should be set mid range. The front panel TRIG toggle switch should be in the INT position. The DELAY controls and the scope triggering controls are then adjusted to obtain a stable output. The scope may then be used to set the desired PRF by rotating the PRF and PRF FINE controls.
- 5) The output pulse amplitude is controlled by means of the front panel one turn AMP control.
- 6) To voltage control the output amplitude, remove the jumper wire between banana plugs A and B on the back panel and apply 0 to +10V to connector B ($R_{IN} \geq 10K$). (option).

- 7) An external clock may be used to control the output PRF of the AVR unit by setting the front panel TRIG toggle switch in the EXT position and applying a 0.2 usec (approx.) TTL level pulse to the TRIG BNC connector input. For operation in this mode, the scope time base must also be triggered by the external clock rather than from the SYNC output.
- 8) The AVR-3-PW features an output impedance of the order of several ohms (rather than 50 ohms). The following consequences of this feature should be noted:
 - a) When used to switch some semiconductor devices (eg. bipolar and VMOS power transistors), the AVR unit will yield much faster switching times than those provided by 50 ohm pulse generators.
 - b) The AVR unit will safely operate in to load impedances in the range of 50 ohms to an open circuit. However, the fall time may degrade for load impedances higher than fifty ohms.
 - c) The AVR unit may be effectively converted to a fifty ohm output impedance generator by placing a fifty ohm 1/2 watt carbon composition resistor in series with the output of the unit and the load. The maximum available load voltage will then decrease to 100 volts (from 200 volts).
 - d) The output switching elements may fail if the unit is inadvertently operated into a short circuit. The switching elements are easily replaced in the field following the procedure outlined in the REPAIR Section.
- 9) S.N. 4093 MOD MAY 1988.

This unit was modified to include a rear panel two position switch which controls the power supply bypass capacitance on the output stage. With the switch in the low position, the output amplitude will fall about 10 times more rapidly (when the AMP knob is turned counter clockwise) than when the switch is in the high position. However, the output droop is about 10 times higher when the switch is in the low position. For operation at 100 Hz PRF and PW of 1.0 nsec, the output decay time in the low position is about 3 sec and about 30 sec in the high position.

Fig. 2

FRONT PANEL CONTROLS

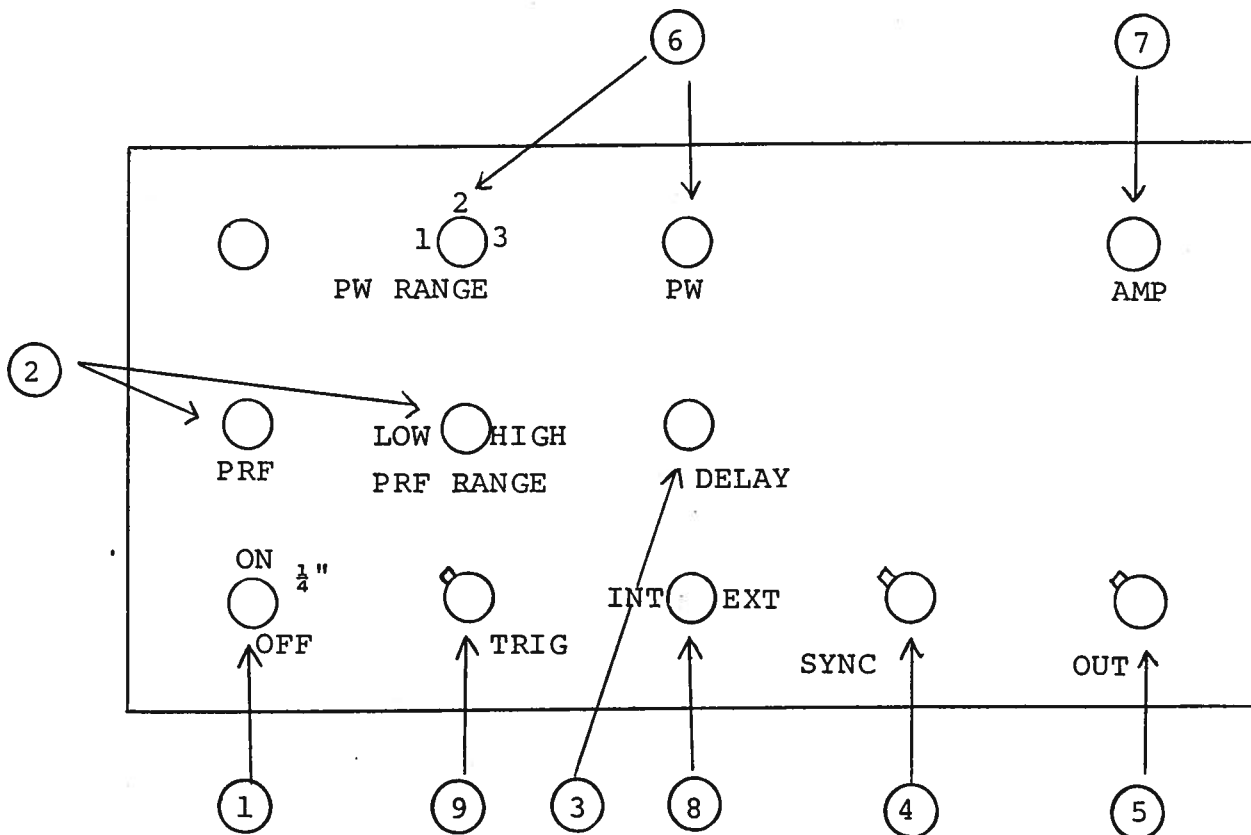

- (1) ON-OFF Switch. Applies basic prime power to all stages.
- (2) PRF Control. Varies PRF from 50 Hz to 1 KHz (HIGH) and 5 Hz to 100 Hz (LOW).
- (3) DELAY Control. Controls the relative delay between the reference output pulse provided at the SYNC output (4) the main output (5). This delay is variable over the range of 0 to about 1.0 usec.
- (4) SYNC Output. This output precedes the main output (5) and (6) and is used to trigger the scope time base. The output is a TTL level 100 nsec (approx.) pulse capable of driving a fifty ohm load.
- (5) OUT Connector. BNC connector provides output to a fifty ohm load.
- (6) PW Control. A one turn control and 3 position range switch which varies the positive output pulse width from 0.1 usec to 10 usec. The minimum and maximum PW for each range and the corresponding maximum PRF are as follows. Note that the unit may fail if operated at duty cycles exceeding the above.

	PW min	PW max
Range 1	0.1 usec PRF max 1 KHz	1.0 usec PRF max 1 KHz
Range 2	1.0 usec PRF max 1 KHz	10 usec PRF max 500 Hz
Range 3	10 usec PRF max 500 Hz	100 usec PRF max 50 Hz

- (7) AMP P Control. A one turn control which varies the positive output pulse amplitude from 0 to 200 V to a fifty ohm load.
- (8) EXT-INT Control. With this toggle switch in the INT position, the PRF of the AVR unit is controlled via an internal clock which in turn is controlled by the PRF and PRF FINE controls. With the toggle switch in the EXT position, the AVR unit requires a 0.2 usec TTL level pulse applied at the TRIG input in order to trigger the output stages. In addition, in this mode, the scope time base must be triggered by the external trigger source.
- (9) TRIG Input. The external trigger signal is applied at this input when the EXT-INT toggle switch is in the EXT position.

Fig. 3

BACK PANEL CONTROLS

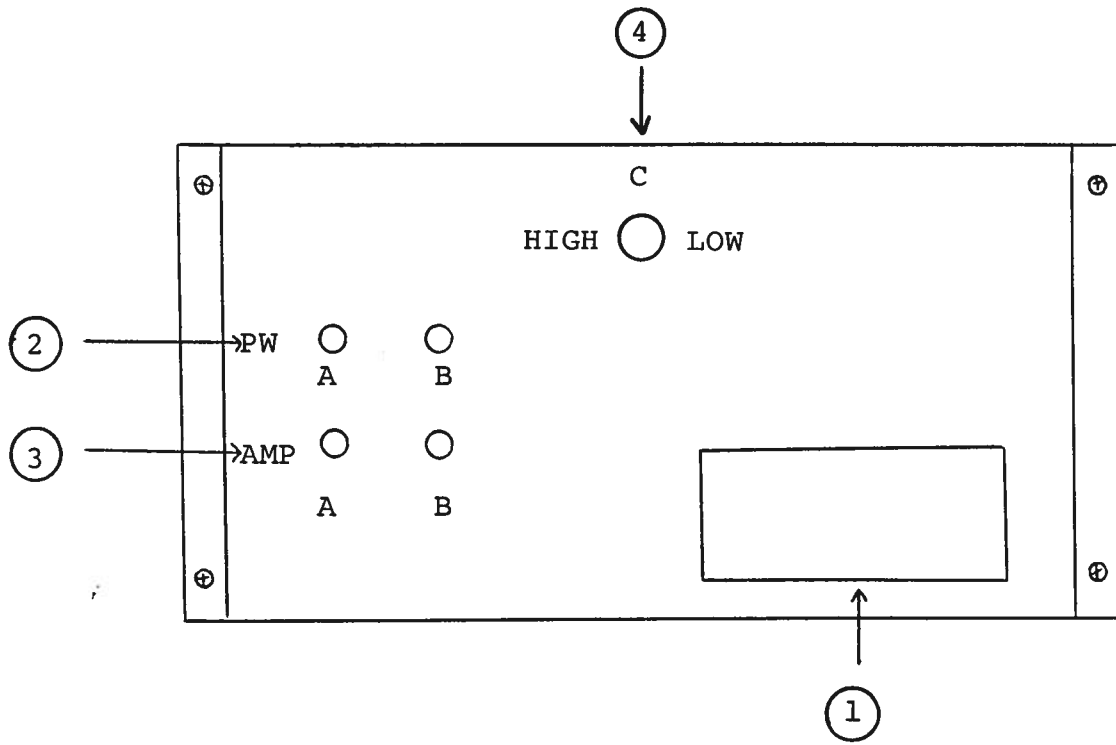

- (1) FUSED CONNECTOR, VOLTAGE SELECTOR. The detachable power cord is connected at this point. In addition, the removable cord is adjusted to select the desired input operating voltage. The unit also contains the main power fuse.
- (2) To voltage control the output pulse width, remove the jumper wire between banana plugs A and B and apply 0 to +10V to connector B ($R_{IN} \gg 10K$). (option).
- (3) To voltage control the output amplitude, remove the jumper wire between banana plugs A and B and apply 0 to +10V to connector B ($R_{IN} \gg 10K$). (option).
- (4) S.N. 4093 MOD MAY 1988.
This unit was modified to include a rear panel two position switch which controls the power supply bypass capacitance on the output stage. With the switch in the low position, the output amplitude will fall about 10 times more rapidly (when the AMP knob is turned counter clockwise) than when the switch is in the high position. However, the output droop is about 10 times higher when the switch is in the low position. For operation at 100 Hz PRF and PW of 1.0 nsec, the output decay time in the low position is about 3 sec and about 30 sec in the high position.

SYSTEM DESCRIPTION AND REPAIR PROCEDURE

The AVR-3-PW-C consists of the following basic modules:

- 1) AVR-3-PW-PG pulse generator module
- 2) AVR-3-CL clock module
- 3) +24V power supply board
- 4) AVR-3-PS power supply module
- 5) AVR-3-PW pulse width module

The modules are interconnected as shown in Fig. 4

The clock module controls the output PRF and the relative delay between the main output and the SYNC outputs. The PG pulse generator module generates the output pulse. The PS module generates 0 to 210 volts to power the pulse generator module. The PW module controls the output pulse width. In the event of an instrument malfunction, it is most likely that some of the output switching elements (SL4H) may have failed due to an output short circuit condition or to a high duty cycle condition. The switching elements may be accessed by removing the cover plate on the bottom side of the instrument. NOTE: First turn off the prime power. The elements may be removed from their sockets by means of a needle nosed pliers. The SL4H is a selected VMOS power transistor in a TO 220 packages and may be checked on a curve tracer. If defective, replacement units should be ordered directly from Avtech. When replacing the SL4H switching elements, take care to insure that the short lead (of the three leads) is adjacent to the black dot on the chassis. If the switching elements are not defective, then the four Phillips screws on the back panel should be removed. The top cover may then be slid off and operation of the clock and power supply modules should be checked. The clock module is functioning properly if:

- a) 0.1 usec TTL level outputs are observed at pins 2 and 3.
- b) The PRF of the outputs can be varied over the range of 50 Hz to 1.0 KHz using the PRF controls.
- c) The relative delay between the pin 2 and 3 outputs can be varied by at least 1.0 usec by the DELAY controls.

The sealed clock module must be returned to Avtech for repair or replacement if the above conditions are not observed. The power supply board generates +24V DC to power the other modules. If the voltage is less than +24V, turn off the prime power and unsolder the lead from the 7824 regulator chip on the power supply board. Solder a 100 ohm 5 watt resistor to the 7824 output to ground and turn on the prime power. A voltage of +24 volts should be read. If the voltage is less then the power supply board is defective and should be repaired or replaced.

Fig. 4a

POWER SUPPLY

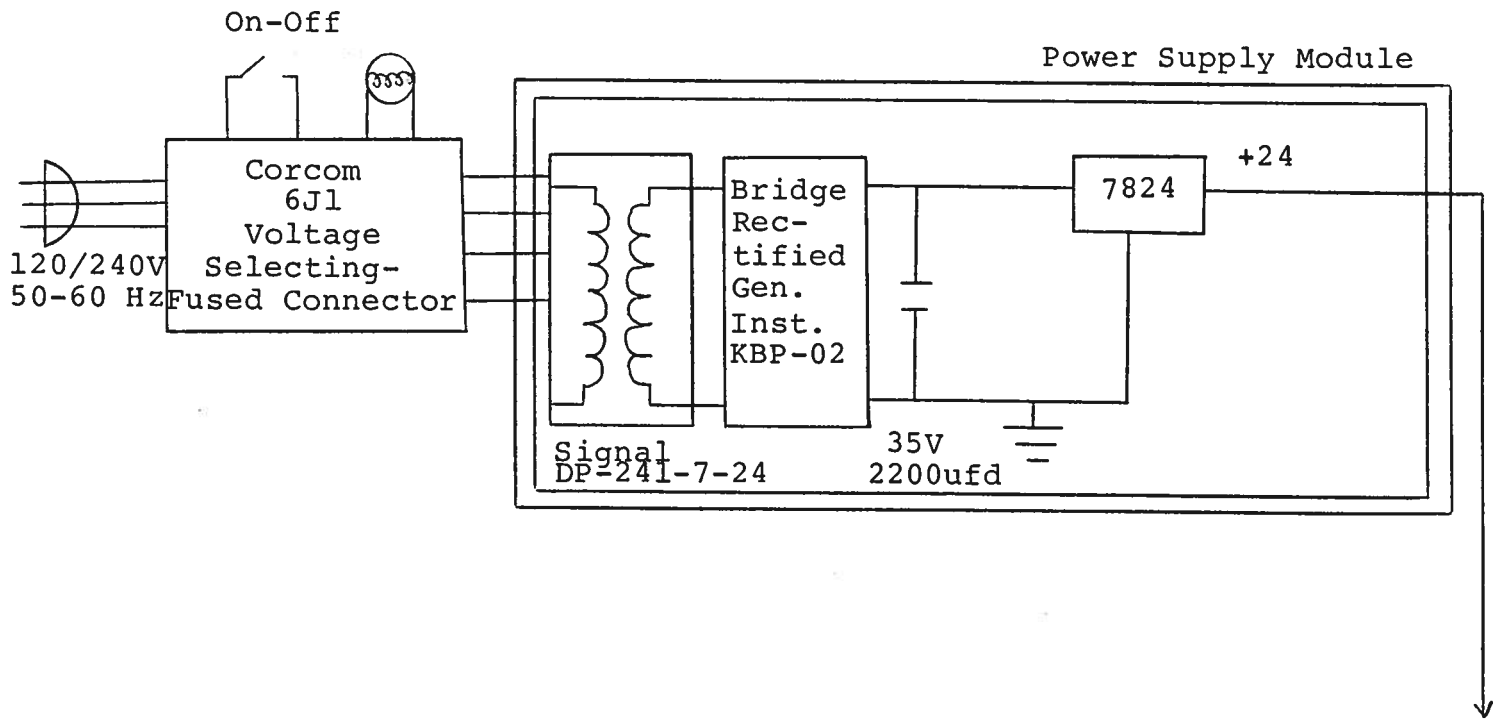
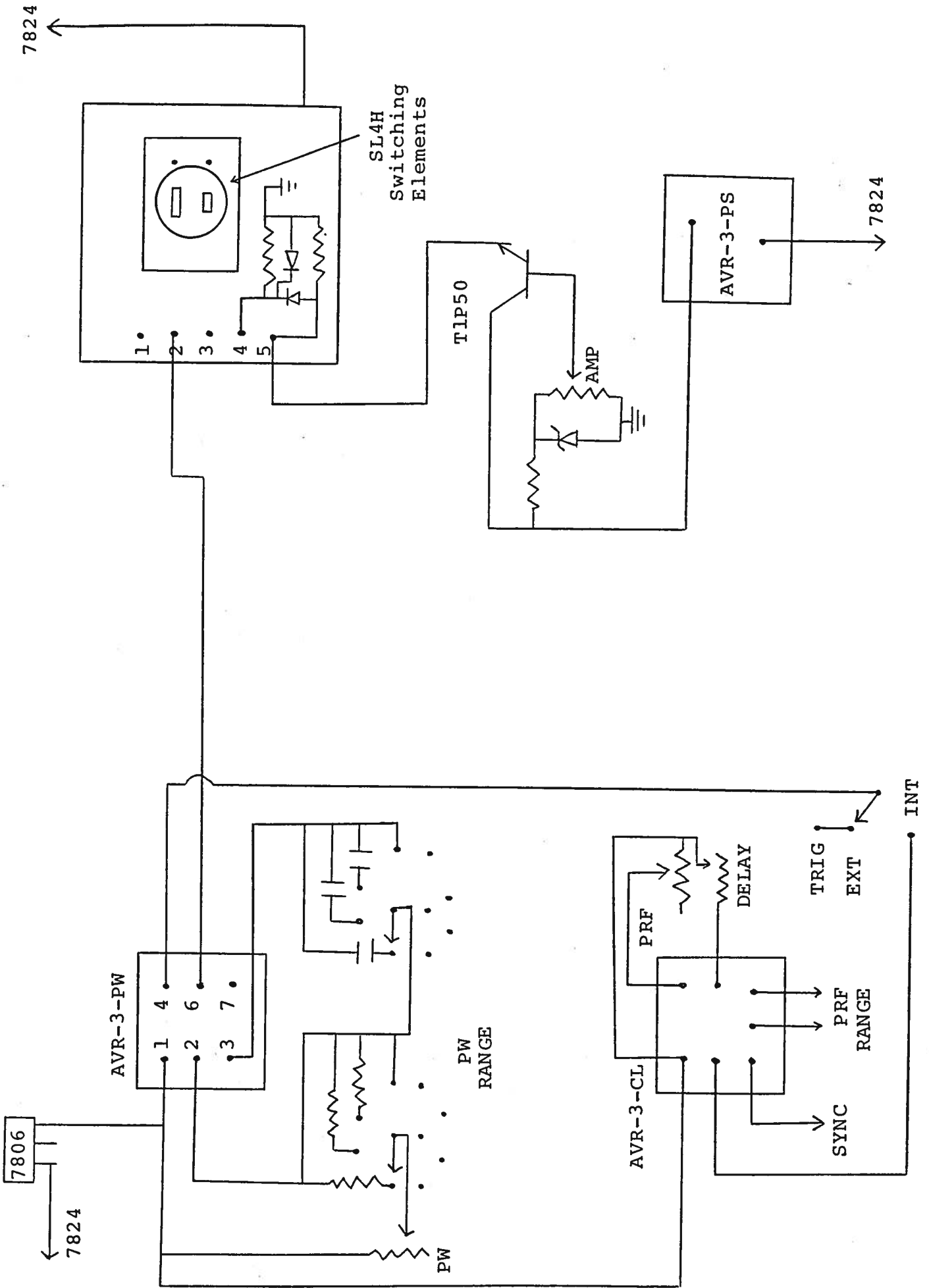

Fig. 4b

Fig. 4b SYSTEM BLOCK DIAGRAM



Schroff 05.13.88

-ER

-EW