

AVTECH ELECTROSYSTEMS LTD.

NANOSECOND WAVEFORM ELECTRONICS
ENGINEERING - MANUFACTURING

P.O. BOX 265
OGDENSBURG
NEW YORK
13669
(315) 472-5270

BOX 5120, STN. "F"
OTTAWA, ONTARIO
CANADA K2C 3H4
TEL: (613) 226-5772
FAX: (613) 226-2802
TELEX: 053-4591

INSTRUCTIONS

MODEL AVR-3-C-N-WSU1 PULSE GENERATOR

S.N.:

WARRANTY

Avtech Electrosystems Ltd. warrants products of its manufacture to be free from defects in material and workmanship under conditions of normal use. If, within one year after delivery to the original owner, and after prepaid return by the original owner, this Avtech product is found to be defective, Avtech shall at its option repair or replace said defective item. This warranty does not apply to units which have been disassembled, modified or subjected to conditions exceeding the applicable specifications or ratings. This warranty is the extent of the obligation or liability assumed by Avtech with respect to this product and no other warranty or guarantee is either expressed or implied.

Fig. 1

PULSE GENERATOR TEST ARRANGEMENT

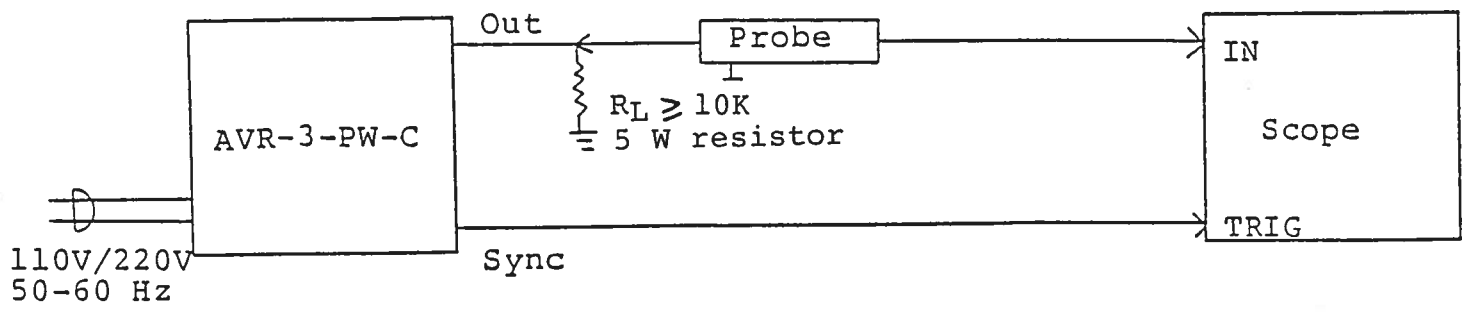

GENERAL OPERATING INSTRUCTIONS

- 1) The equipment should be connected in the general fashion shown above. Since the AVR unit provides an output pulse rise time as low as 10 nsec a fast oscilloscope (at least 50 MHz and preferably 200 MHz) should be used to display the waveform.
- 2) The sync output channel provides TTL level signals.
- 3) The unit provides a square wave output (50% duty cycle) of the form shown in Fig. 2. CAUTION: This unit is designed to drive a high impedance load (eg. $R_L \gg 10K$) and may fail if operated into a low-impedance load (eg. 50 ohms).
- 4) The output PRF (or PW) is controlled by the 3 position range switch and one turn PRF control from 1 KHz to 1 MHz (or 0.5 msec to 0.5 usec).
- 5) The output amplitude is controlled by the one turn amp control (0 to 200 volts to 10K or larger).
- 6) The PRF is controlled by the internal clock when the INT-EXT switch is in the INT position. With the switch in the INT position and the DELAY switch in the LEAD position, a TTL level coincident replica of the main output pulse is provided at the TRIG output. This TTL signal may be used for scope triggering purposes. When the DELAY switch is in the LAG position, the TRIG output provides a 0.2 usec wide TTL level pulse which is delayed with respect to the rising edge of the output square wave. The amount of delay is variable from approximately 100 nsec to 1 msec and is controlled by the 3 position DELAY RANGE switch and the one turn delay control.
- 7) The unit may be triggered externally by setting the INT-EXT switch in the EXT position and applying a TTL level 50% duty cycle square wave to the TRIG input. The output will then have the same PRF as the TTL input but delayed by approximately 100 nsec.
- 8) The output switching elements may fail if the unit is inadvertently operated into a short circuit or low impedance. The switching elements are easily replaced in the field following the procedure outlined in the REPAIR Section.

Fig. 2

FRONT PANEL CONTROLS

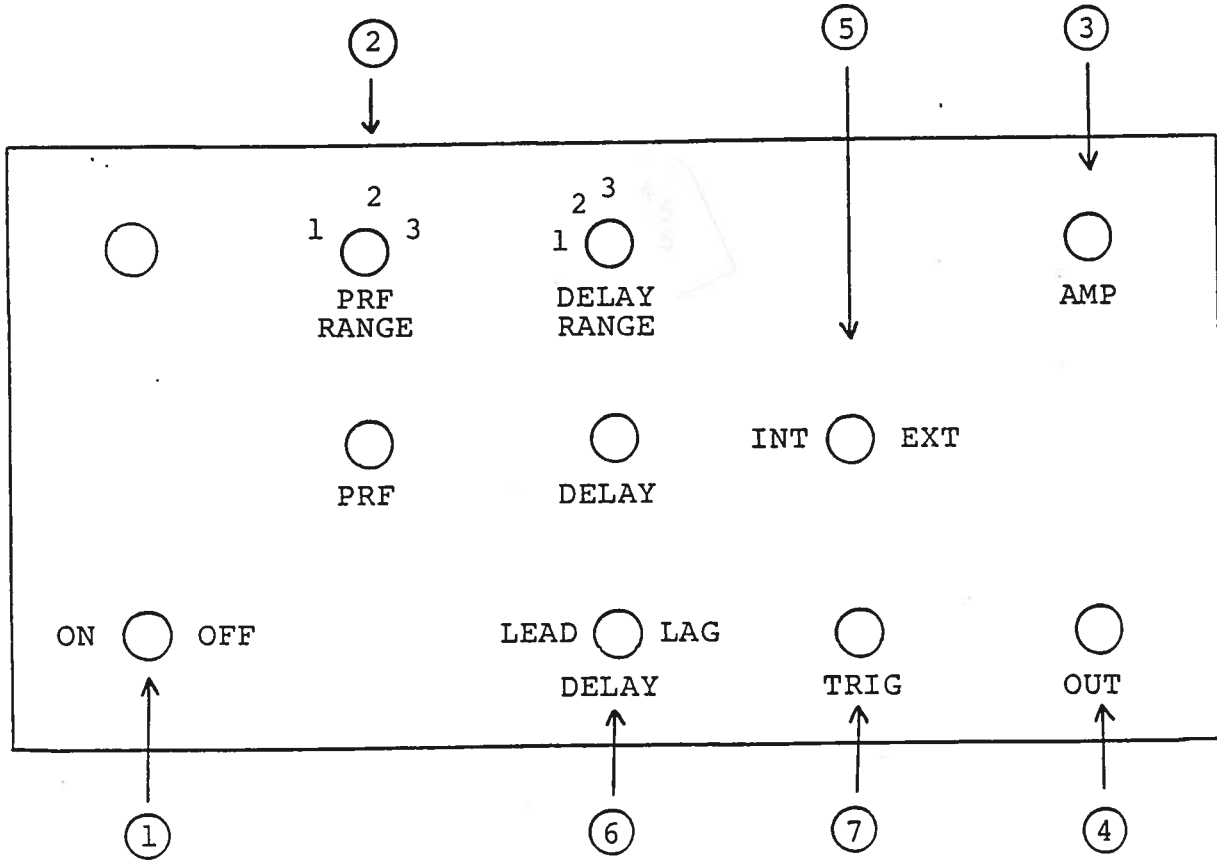

- (1) ON-OFF Switch. Applies basic prime power to all stages.
- (2) PRF Control. Varies PRF from 1 KHz to 1 MHz.
- (3) AMP Control. A one turn control which varies the output pulse amplitude from 0 to 200V to 10K or higher.
- (4) OUT. SMA connector provides output to high impedance load.
- (5) INT-EXT. The PRF is controlled by the internal clock when the INT-EXT switch is in the INT position. With the switch in the INT position and the DELAY switch (6) in the LEAD position, a TTL level coincident replica of the main output pulse is provided at the TRIG output (7). This TTL signal may be used for scope triggering purposes. When the DELAY switch (6) is in the LAG position, the TRIG output (7) provides a 0.2 usec wide TTL level pulse which is delayed with respect to the rising edge of the output square wave. The amount of delay is variable from approximately 100 nsec to 10 usec and is controlled by the 3 position DELAY RANGE switch and the one turn delay control as follows:

Range	MIN	MAX
1	100 nsec	10 usec
2	1 usec	100 usec
3	10 usec	1 msec

- (6) DELAY. See (5) above.
- (7) TRIG. The unit may be triggered externally by setting the INT-EXT switch (5) in the EXT position and applying a TTL level 50% duty cycle square wave to the TRIG input. The output will then have the same PRF as the TTL input but delayed by approximately 100 nsec. When the INT-EXT switch (5) is in the INT position, a coincident TTL level replica of the main output is provided at the TRIG output (see 5 above).

Fig. 3

BACK PANEL CONTROLS

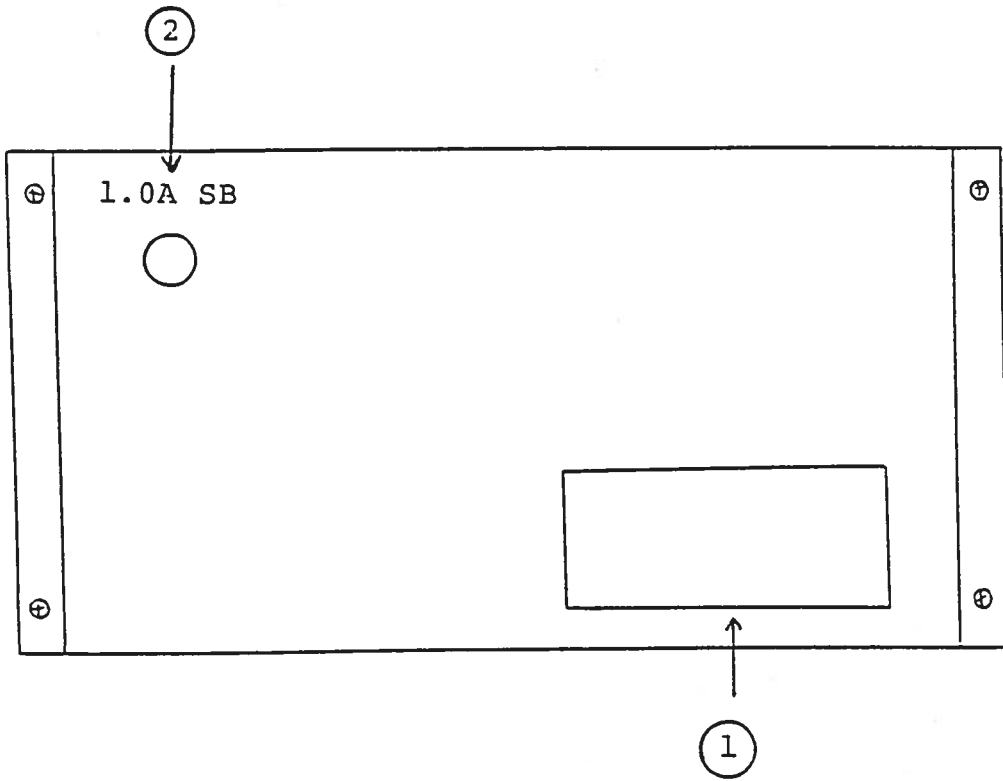

- (1) FUSED CONNECTOR, VOLTAGE SELECTOR. The detachable power cord is connected at this point. In addition, the removable cord is adjusted to select the desired input operating voltage. The unit also contains the main power fuse (0.5A).
- (2) 1.0A SB. This fuse limits the DC prime power supplied to the output stage and will blow in the case of severe overloading.

SYSTEM DESCRIPTION AND REPAIR PROCEDURE

The AVR-3-PW-C consists of the following basic modules:

- 1) AVR-3-PW-PG-P pulse generator module
- 2) AVR-3-CL clock module
- 3) +24V power supply board
- 4) AVR-3-PS power supply module

In the event of an instrument malfunction, it is most likely that the 1.0 A slow blow fuse or the main power fuse on the rear panel has blown. Replace if necessary. If the unit still does not function, it is most likely that some of the output switching elements (SL9HT) may have failed due to an output short circuit condition or to a high duty cycle condition. The switching elements may be accessed by removing the cover plate on the bottom side of the instrument. The cover plate is removed by removing the two 2-56 Phillips screws. **NOTE:** First turn off the prime power. **CAUTION:** Briefly ground the SL9HT tabs to discharge the 200 volts power supply potential. The elements may be removed from their sockets by means of a needle nosed pliers after removing the four 2-56 Phillips screws which attach the small copper heat sink to the body of the instrument. The SL9HT is a selected VMOS power transistor in a TO 220 package and may be checked on a curve tracer. If defective, replacement units should be ordered directly from Avtech. When replacing the SL9HT switching elements, take care to insure that the short lead (of the three leads) is adjacent to the back of the chassis. (See following Fig.). The SL9HT elements are electrically isolated from the small copper heat sink but are bonded to the heat sink using WAKEFIELD TYPE 155 HEAT SINK ADHESIVE.

SL9T HEAT SINKING

BACK

155
HEAT SINK
ADHESIVE*

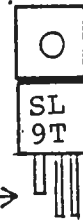
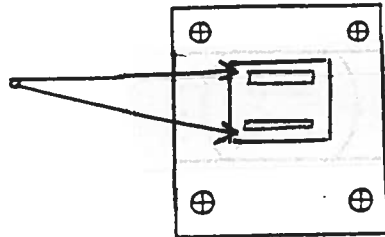

SHORT LEAD →

Schroff

04.30.90

