



AVTECH ELECTROSYSTEMS LTD.

NANOSECOND WAVEFORM ELECTRONICS
SINCE 1975

□ P.O. BOX 265
OGDENSBURG, NY
U.S.A. 13669-0265
TEL: (315) 472-5270
FAX: (613) 226-2802

TEL: 1-800-265-6681
FAX: 1-800-561-1970
U.S.A. & CANADA

e-mail: info@avtechpulse.com

□ BOX 5120 STN. F
OTTAWA, ONTARIO
CANADA K2C 3H4
TEL: (613) 226-5772
FAX: (613) 226-2802

INSTRUCTIONS

MODEL AVR-3-PW-C-PN-PWT-AT-OP2 PULSE GENERATOR

S.N. :

WARRANTY

Avtech Electrosystems Ltd. warrants products of its manufacture to be free from defects in material and workmanship under conditions of normal use. If, within one year after delivery to the original owner, and after prepaid return by the original owner, this Avtech product is found to be defective, Avtech shall at its option repair or replace said defective item. This warranty does not apply to units which have been disassembled, modified or subjected to conditions exceeding the applicable specifications or ratings. This warranty is the extent of the obligation or liability assumed by Avtech with respect to this product and no other warranty or guarantee is either expressed or implied.

Fig. 1

PULSE GENERATOR TEST ARRANGEMENT

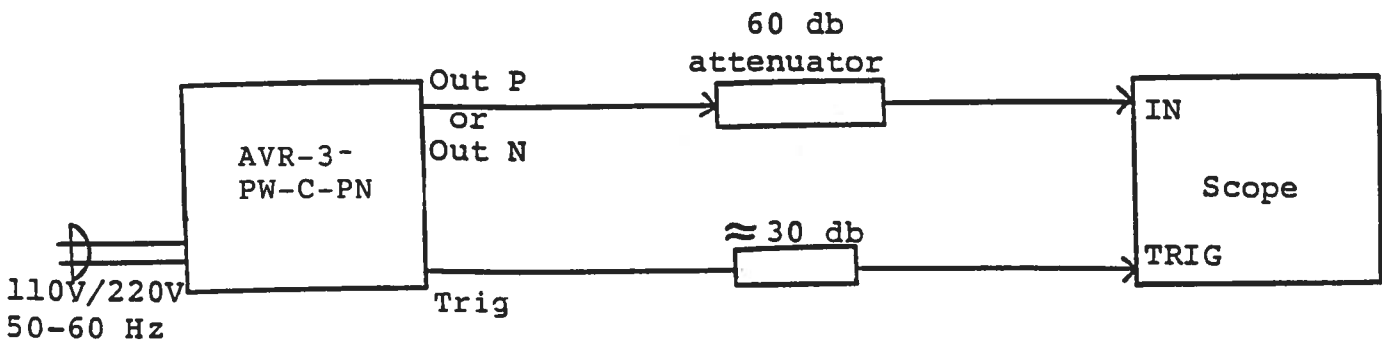

Notes:

- 1) For front panel manual control of the output parameters the rear panel LOCAL-REMOTE switch must be in the LOCAL position. For remote control using the PINNACLE INSTRUMENTS PC-1 controller, the switch should be in the REMOTE position. See the PC-1 instruction manual for this mode of operation.
- 2) The bandwidth capability of components and instruments used to display the pulse generator output signal (attenuators, cables, connectors, etc.) should exceed 100 MHz. The use of 60 db attenuator at the scope vertical input channel will insure a peak input signal to the scope of less than one volt (necessary only if sampling scope used). If a high impedance real time scope is used, the pulse generator should be terminated using a shunt 50 Ohm resistor (4 Watts).
- 3) The TRIG output channel provides TTL level signals. To avoid overdriving the TRIG input channel of some scopes, a 30 dB attenuator should be placed at the input to the scope trigger channel. The TRIG output precedes the main output when the front panel ADVANCE-DELAY switch is in the ADVANCE position. The TRIG output lags the main output when the switch is in the DELAY position.
- 4) To obtain a stable output display the PRF control on the front panel should be set mid range. The front panel TRIG switch should be in the INT position. The DELAY controls and the scope triggering controls are then adjusted to obtain a stable output. The scope may then be used to set the desired PRF by rotating the PRF controls.
- 5) The output pulse width is controlled by means of the front panel one turn PW control and by the PW RANGE control. The minimum and maximum PW for each range and the corresponding maximum PRF are as follows. Note that the unit may fail if operated at duty cycles exceeding 0.5%.

	PW min	PW max
Range 1	0.1 us PRF max 10 KHz	1.0 us PRF max 5 KHz
Range 2	1.0 us PRF max 5 KHz	10 us PRF max 500 Hz
Range 3	10 us PRF max 500 Hz	100 us PRF max 50 Hz

- 6) The output pulse amplitude is controlled by means of the front panel one turn AMP control (10 turn for -AT option).
- 7) The output pulse polarity is controlled by the front panel two-position polarity switch.

CAUTION: Reduce the output amplitude to zero before changing the polarity.
- 8) An external clock may be used to control the output PRF of the AVR unit by setting the front panel TRIG toggle switch in the EXT position and applying a 0.2 us (approx.) TTL level pulse to the TRIG BNC connector input. For operation in this mode, the scope time base must also be triggered by the external clock rather than from the TRIG output. When triggered externally, the output pulse width is controlled by the front panel PW controls provided the MODE A-B switch is in the A position. The MODE A-B switch is accessed by removing the top cover (by removing the four Phillips screws on the top panel and sliding the top cover back and off). When the MODE A-B switch is in the B position, the output pulse width equals the input trigger pulse width. The unit is shipped with the switch in the A position.
- 9) For single pulse manual operation, set the front panel INT-EXT-MAN switch in the MAN position and push the SINGLE PULSE button.
- 10) The DELAY control controls the relative delay between the reference output pulse provided at the TRIG output and the main output. This delay is variable over the range of 0.5 us to 5 ms. The TRIG output precedes the main output when the ADVANCE-DELAY switch is in the ADVANCE position and lags when the switch is in the DELAY position.

	MIN	MAX
Range 1	0.1 us	1 us
Range 2	1 us	10 us
Range 3	10 us	100 us

- 11) The AVR-3-PW-C features an output impedance of the order of several Ohms (rather than 50 Ohms). The following consequences of this feature should be noted:
- a) When used to switch some semiconductor devices (eg. bipolar and VMOS power transistors), the AVR unit will yield much faster switching times than those provided by 50 Ohm pulse generators.
 - b) The AVR unit will safely operate in to load impedances in the range of 50 Ohms to an open circuit. However, the fall time may degrade for load impedances higher than fifty Ohms.
 - c) The AVR unit may be effectively converted to a fifty Ohm output impedance generator by placing a fifty Ohm 1/2 Watt carbon composition resistor in series with the output of the unit and the load. The maximum available load voltage will then decrease to 100 Volts (from 200 Volts).
- 12) AVR-3-PW-C units with a serial number higher than 5600 are protected by an automatic overload protective circuit which controls the front panel overload light. If the unit is overloaded (by operating at an exceedingly high duty cycle or by operating into a short circuit), the protective circuit will turn the output of the instrument OFF and turn the indicator light ON. The light will stay ON (i.e. output OFF) for about 5 seconds after which the instrument will attempt to turn ON (i.e. light OFF) for about 1 second. If the overload condition persists, the instrument will turn OFF again (i.e. light ON) for another 5 seconds. If the overload condition has been removed, the instrument will turn on and resume normal operation. Overload conditions may be removed by:
- 1) Reducing PRF (i.e. switch to a lower range)
 - 2) Reducing pulse width (i.e. switch to a lower range)
 - 3) Removing output load short circuit (if any)
- 13) The unit can be converted from 120 to 240V 50-60 Hz operation by adjusting the voltage selector card in the rear panel fused voltage selector-cable connector assembly.
- 14) For additional information:
- Tel: (613) 226-5772
Fax: (613) 226-2802

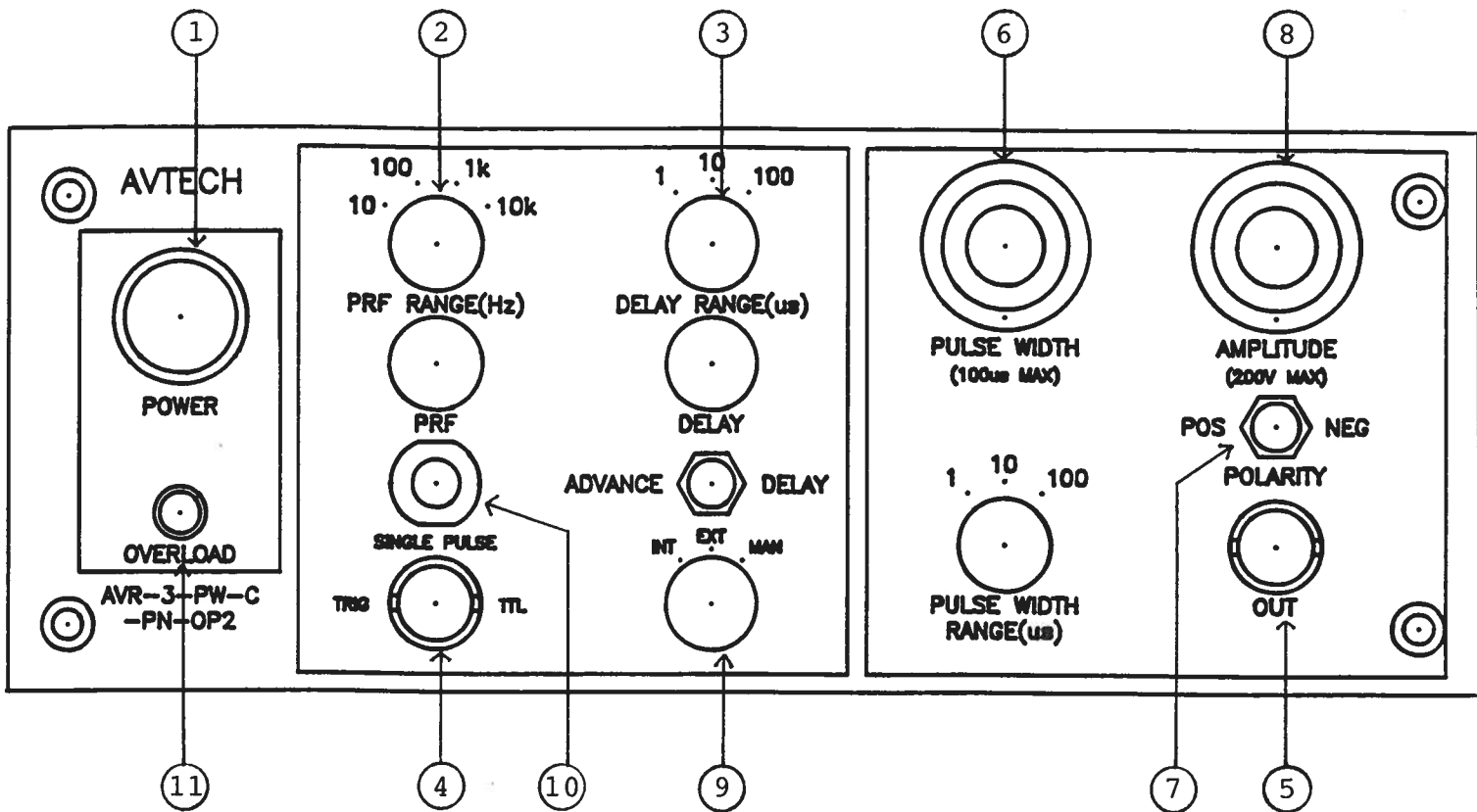

Fig. 2

FRONT PANEL CONTROLS

FRONT PANEL CONTROLS

(1) ON-OFF Switch. Applies basic prime power to all stages.

(2) PRF Control. Varies PRF from 1 Hz to 10 kHz as follows:

1 Hz	to	10 Hz
10 Hz	to	100 Hz
100 Hz	to	1 kHz
1 kHz	to	10 kHz

(3) DELAY Control. Controls the relative delay between the reference output pulse provided at the TRIG output (4) the main output (5). This delay is variable over the range of 0.1 to about 100 us. Delay LEADS or LAGS depending on the position of the ADVANCE-DELAY switch.

	MIN	MAX
Range 1	0.1 us	1.0 us
Range 2	1.0 us	10 us
Range 3	10 us	100 us

(4) TRIG Output. This output is used to trigger the scope time base. The output is a TTL level 100 ns (approx.) pulse capable of driving a fifty Ohm load. This output precedes the output at (5) if the two position ADVANCE-DELAY switch is in the ADVANCE position. This output follows the output at (5) if the switch is in the DELAY position. The delay range is variable from 0.1 us to 100 us. The external trigger signal is applied at this input when the EXT-INT toggle switch is in the EXT position.

(5) OUT Connector. BNC connector provides output to a 50 Ohm load (or higher).

(6) PW Control. A one turn control (ten turn for -PWT option) and three position range switch which varies the output pulse width as follows:

100 ns	to	1.0 us
1.0 us	to	10 us
10 us	to	100 us

- (7) POLARITY. This two-position switch controls the polarity of the output pulse provided at the OUT terminal (5).

CAUTION: Reduce output amplitude to zero before reversing the polarity.

- (8) AMP Control. A one turn control (ten turn for -AT option) which varies the output pulse amplitude from 0 to 200 V.
- (9) INT-EXT-MAN Control. With this toggle switch in the INT position, the PRF of the AVR unit is controlled via an internal clock which in turn is controlled by the PRF control. With the toggle switch in the EXT position, the AVR unit requires a 0.2 us TTL level pulse applied at the TRIG input in order to trigger the output stages. In addition, in this mode, the scope time base must be triggered by the external trigger source. When triggered externally, the output pulse width is controlled by the front panel PW controls provided the MODE A-B switch is in the A position. The MODE A-B switch is accessed by removing the top cover (by removing the four Phillips screws on the top panel and sliding the top cover back and off). When the MODE A-B switch is in the B position, the output pulse width equals the input trigger pulse width. The unit is shipped with the switch in the A position.
- (10) SINGLE PULSE. For single pulse manual operation, set the front panel INT-EXT-MAN switch in the MAN position and push the SINGLE PULSE button.
- (11) OVERLOAD INDICATOR. AVR-3-PW-C units with a serial number higher than 5600 are protected by an automatic overload protective circuit which controls the front panel overload light. If the unit is overloaded (by operating at an exceedingly high duty cycle or by operating into a short circuit), the protective circuit will turn the output of the instrument OFF and turn the indicator light ON. The light will stay ON (i.e. output OFF) for about 5 seconds after which the instrument will attempt to turn ON (i.e. light OFF) for about 1 second. If the overload condition persists, the instrument will turn OFF again (i.e. light ON) for another 5 seconds. If the overload condition has been removed, the instrument will turn on and resume normal operation. Overload conditions may be removed by:
- 1) Reducing PRF (i.e. switch to a lower range)
 - 2) Reducing pulse width (i.e. switch to a lower range)
 - 3) Removing output load short circuit (if any)

Fig. 3

BACK PANEL CONTROLS

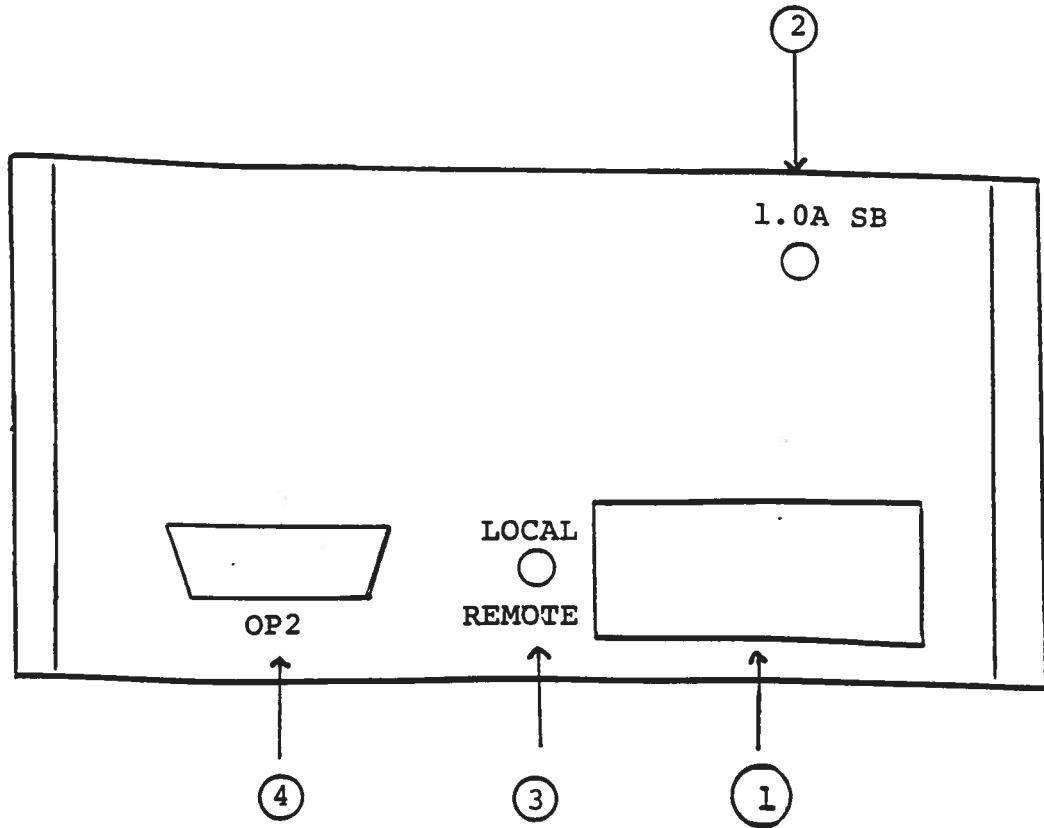

- (1) FUSED CONNECTOR, VOLTAGE SELECTOR. The detachable power cord is connected at this point. In addition, the removable cord is adjusted to select the desired input operating voltage. The unit also contains the main power fuse (0.5A SB).
- (2) 1.0A SB. Fuse which protects the output stage if the output duty cycle rating is exceeded.
- (3) LOCAL REMOTE SWITCH. This two-position switch must be in the LOCAL position to operate the instrument from the front panel controls. To control the instrument using the PINNACLE INSTRUMENTS Model PC-1, the switch must be in the REMOTE position.
- (4) OP2 CONNECTOR. 36 conductor CENTRONICS CAT. NO. 45-4395 cable (supplied) connects between this connector and the PINNACLE INSTRUMENTS Model PC-1.

TOP COVER REMOVAL AND RACK MOUNTING

- 1) The interior of the instrument may be accessed by removing the four Phillips screws on the top panel. With the four screws removed, the top cover may be slid back (and off).

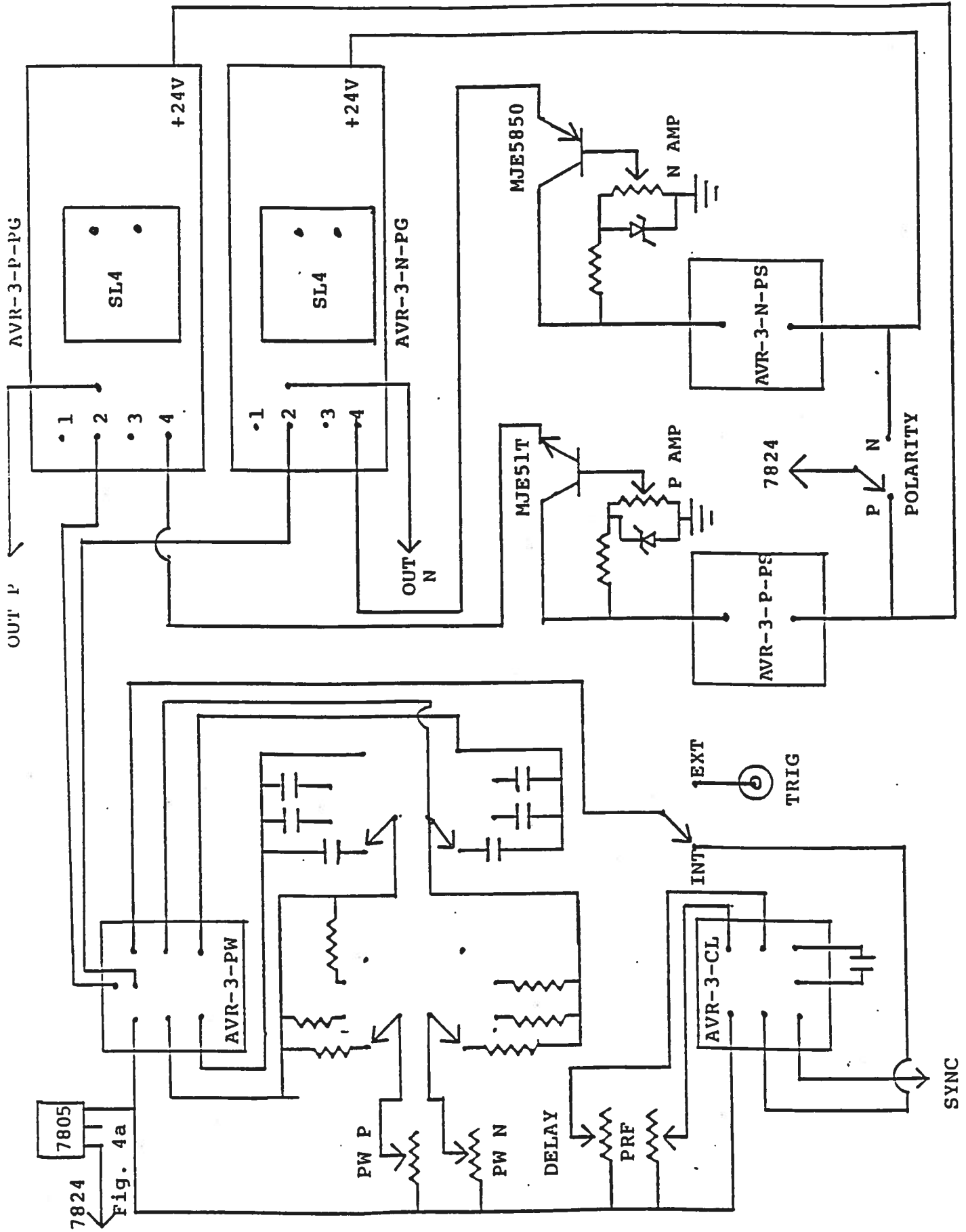

Fig. 4b SYSTEM BLOCK DIAGRAM (FOR NON EA, EW OPTION UNITS)

Fig. 4a

POWER SUPPLY

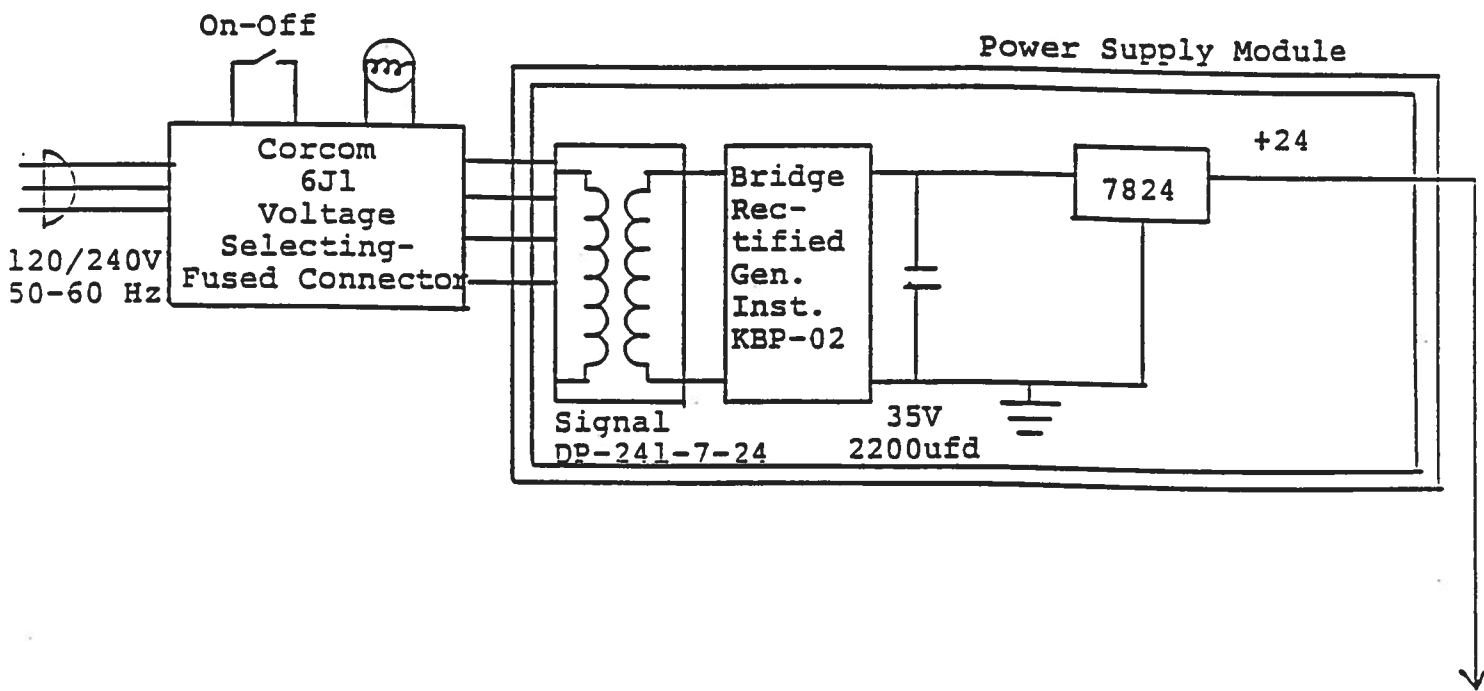

Fig. 4b

SYSTEM DESCRIPTION AND REPAIR PROCEDURE

The AVR-3-PW-C-OP2 consists of the following basic modules:

- 1) AVR-3-PW-PG pulse generator modules (P & N)
- 2) -OP2 control board
- 3) +24V power supply board
- 4) AVR-3-PS power supply module
- 5) AVR-3-PW pulse width module
- 6) -OL overload module

The modules are interconnected as shown in Fig. 4.

The -OP2 board controls the output pulse width, the output PRF and the relative delay between the main output and the TRIG output. The PG pulse generator modules generate the output pulse. In the event of an instrument malfunction, it is most likely that the rear panel 1.0A SB fuse or 0.5A line fuse may have failed due to an output short circuit condition or to a high duty cycle condition. If the fuse is not blown, then it is recommended that the unit be returned to Avtech for servicing.

Disk: AVR-3-C1 (current)

disk name: 3PWCPNOP.INS.

08.29.95.