

AVTECH ELECTROSYSTEMS LTD.

NANOSECOND WAVEFORM ELECTRONICS
ENGINEERING - MANUFACTURING

□ P.O. BOX 265
OGDENSBURG
NEW YORK
13669
(315) 472-5270

☒ BOX 5120, STN. "F"
OTTAWA, ONTARIO
CANADA K2C 3H4
TEL: (613) 226-5772
FAX: (613) 226-2802
TELEX: 053-4591

INSTRUCTIONS

MODEL AVR-4A-PW-C-PN-EA-EW-CNR1 PULSE GENERATOR

S.N. :

WARRANTY

Avtech Electrosystems Ltd. warrants products of its manufacture to be free from defects in material and workmanship under conditions of normal use. If, within one year after delivery to the original owner, and after prepaid return by the original owner, this Avtech product is found to be defective, Avtech shall at its option repair or replace said defective item. This warranty does not apply to units which have been disassembled, modified or subjected to conditions exceeding the applicable specifications or ratings. This warranty is the extent of the obligation or liability assumed by Avtech with respect to this product and no other warranty or guarantee is either expressed or implied.

Fig. 1

PULSE GENERATOR TEST ARRANGEMENT

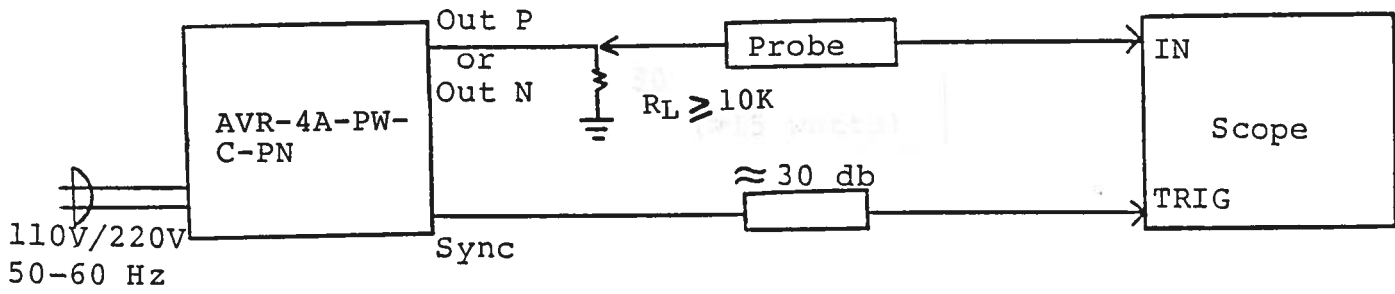

Notes:

- 1) The bandwidth capability of components and instruments used to display the pulse generator output signal (attenuators, cables, connectors, etc.) should exceed 100 MHz.
- 2) The sync output channel provides TTL level signals. To avoid overdriving the TRIG input channel of some scopes, a 30 db attenuator should be placed at the input to the scope trigger channel.
- 3) To obtain a stable output display the PRF control on the front panel should be set mid range. The front panel TRIG toggle switch should be in the INT position. The DELAY controls and the scope triggering controls are then adjusted to obtain a stable output. The scope may then be used to set the desired PRF by rotating the PRF and PRF FINE controls.
- 4) The desired output polarity is selected by means of the front panel POLARITY switch. With the POLARITY switch in the P position, the negative output pulse generator is rendered inactive. Likewise, with the POLARITY switch in the N position, the positive pulse generator is rendered inactive.
- 5) The output pulse widths for the positive and negative outputs are controlled by means of the front panel one turn PW control. To voltage control the pulse width, set the rear panel switch in the EXT position and apply 0 to +10 volts between terminal A and ground ($R_{IN} > 10K$).
- 6) The output pulse amplitudes for the positive and negative outputs are controlled by means of the front panel one turn AMP control. To voltage control the output, set the rear panel switch in the EXT position and apply 0 to +10 volts between terminal A and ground ($R_{IN} > 10K$).
- 7) An external clock may be used to control the output PRF of the AVR unit by setting the front panel TRIG toggle switch in the EXT position and applying a 0.2 usec (approx.) TTL level pulse to the TRIG BNC connector input. For operation in this mode, the scope time base must also be triggered by the external clock rather than from the SYNC output.
- 8) CAUTION: The output stage is protected against overload condition by a 1.0 A slow blow fuse on the main frame back panel. However, the output switching elements (SL22T) may fail if the unit is triggered at a PRF exceeding 20 KHz or if the load resistance is substantially less than 10K.

- 9) The unit can be converted from 110 to 220V 50-60 Hz operation by adjusting the voltage selector card in the rear panel fused voltage selector cable connector assembly.

Fig. 2

FRONT PANEL CONTROLS

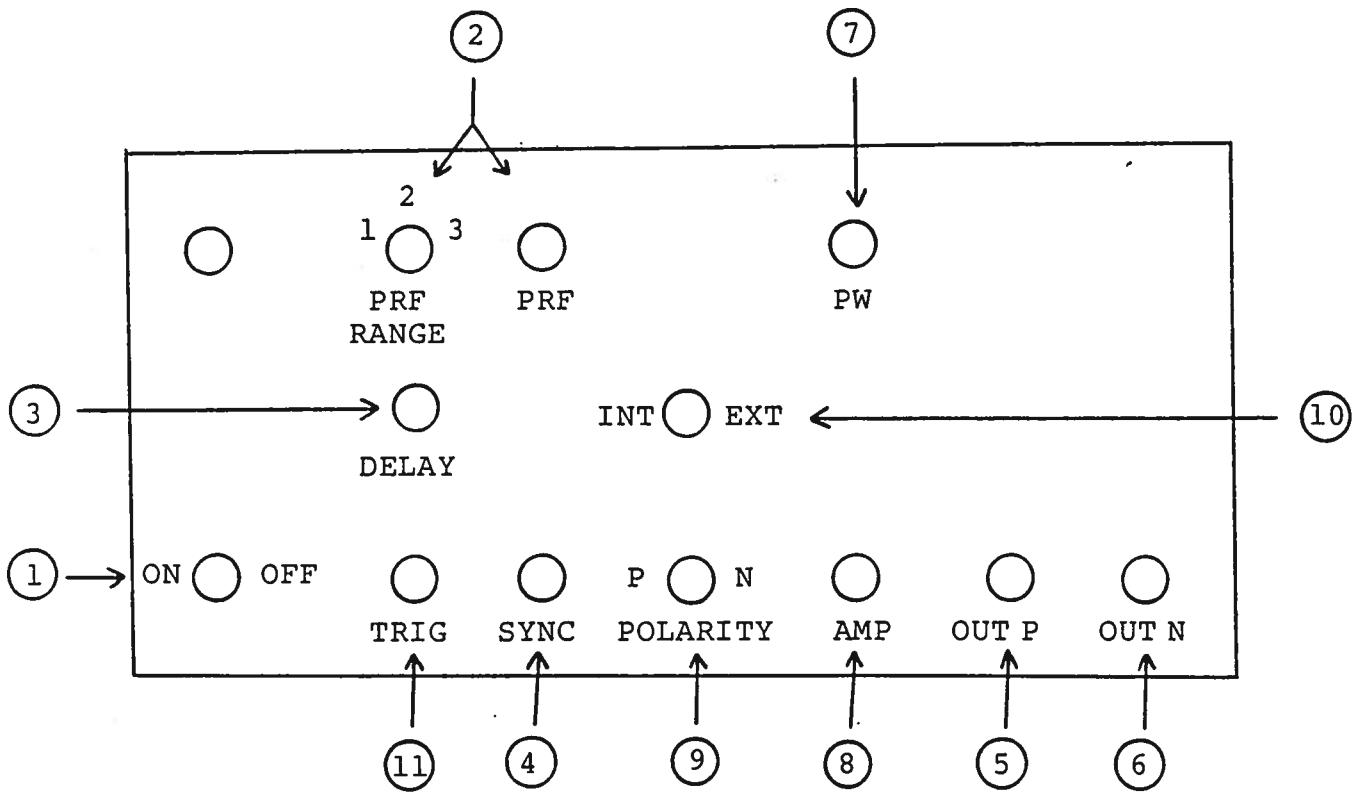

- (1) ON-OFF Switch. Applies basic prime power to all stages.
- (2) PRF Control. Varies PRF from 10 Hz to 1 KHz as follows:

Range 1	2 Hz	200 Hz
Range 2	20 Hz to	2 KHz
Range 3	200 Hz to	20 KHz
- (3) DELAY Control. Controls the relative delay between the reference output pulse provided at the SYNC output (4) the main output (5) and (6). This delay is variable over the range of 0 to about 1.0 usec.
- (4) SYNC Output. This output precedes the main output (5) and (6) and is used to trigger the scope time base. The output is a TTL level 100 nsec (approx.) pulse capable of driving a fifty ohm load.
- (5) OUT N Connector. BNC connector provides output to a high impedance load ($\geq 10K$).
- (6) OUT P Connector. BNC connector provides output to a high impedance load ($\geq 10K$).
- (7) PW Control. A one turn control which varies the positive output pulse width from 0.2 usec to 2 usec.
- (8) AMP Control. A one turn control which varies the output pulse amplitude from 0 to 400 V.
- (9) POLARITY Control. With the switch in the P position, the negative output pulse generator is rendered inactive. With the switch in the N position, the positive output pulse generator is rendered inactive.
- (10) EXT-INT Control. With this toggle switch in the INT position, the PRF of the AVR unit is controlled via an internal clock which in turn is controlled by the PRF and PRF FINE controls. With the toggle switch in the EXT position, the AVR unit requires a 0.2 usec TTL level pulse applied at the TRIG input in order to trigger the output stages. In addition, in this mode, the scope time base must be triggered by the external trigger source.
- (11) TRIG Input. The external trigger signal is applied at this input when the EXT-INT toggle switch is in the EXT position.

Fig. 3

BACK PANEL CONTROLS

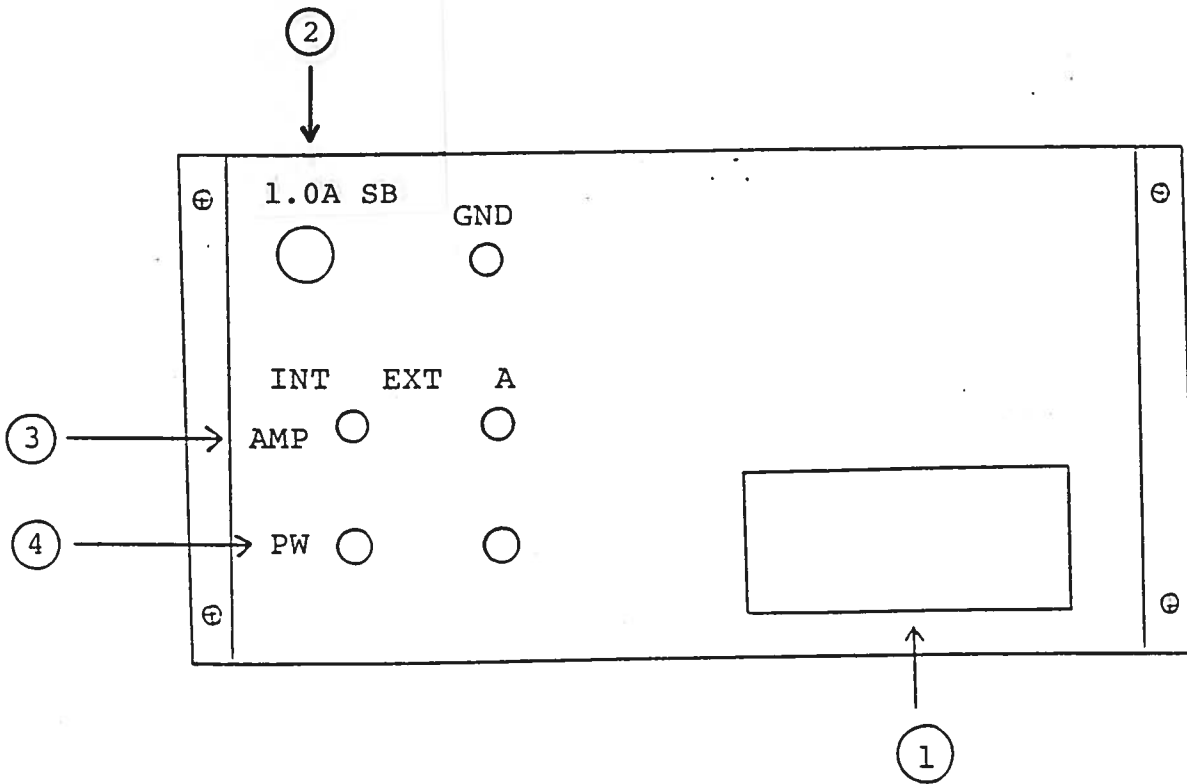

- (1) FUSED CONNECTOR, VOLTAGE SELECTOR. The detachable power cord is connected at this point. In addition, the removable cord is adjusted to select the desired input operating voltage. The unit also contains the main power fuse (0.5 A SB).
- (2) 1.0 A SB. Fuse which protects the output stage if the output duty cycle rating is exceeded.
- (3) EA. To voltage control the output amplitude, set the switch in the EXT position and apply 0 to +10 volts between terminal A and ground ($R_{IN} > 10K$). (option).
- (4) EW. To voltage control the output pulse width, set the switch in the EXT position and apply 0 to +10 volts between terminal A and ground ($R_{IN} > 10K$). (option).

AVR-4A-PW-PN-C BLOCK DIAGRAM

Fig. 4

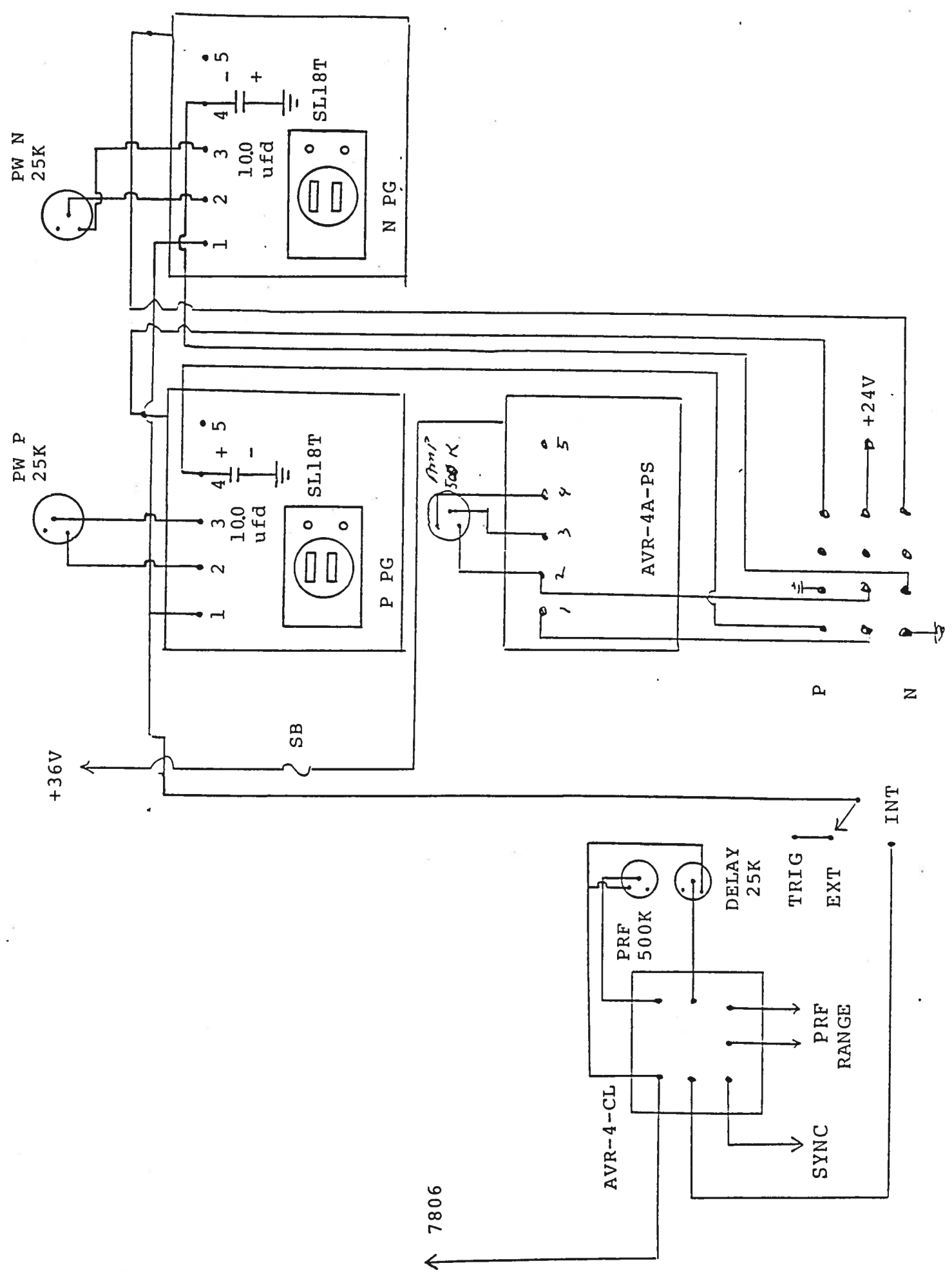

7806

Fig. 4a

POWER SUPPLY

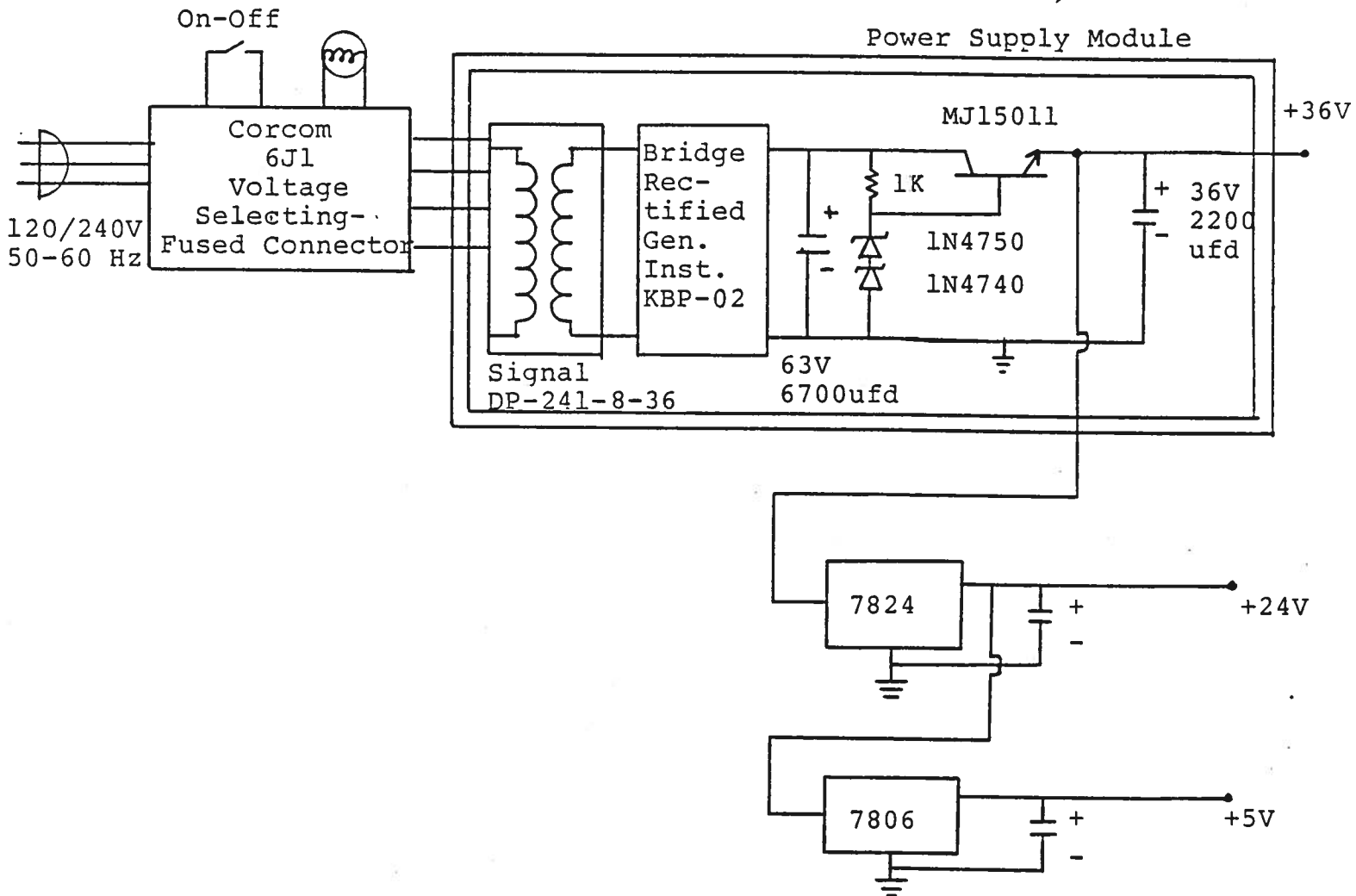

SYSTEM DESCRIPTION AND REPAIR PROCEDURE

The AVR-4-PW-C-PN consists of the following basic modules:

- 1) AVR-4-PW-PG pulse generator modules (-P and -N)
- 2) AVR-4-CL clock module
- 3) +36V, +24V, +5.8V power supply board
- 4) AVR-4-PS power supply module
- 5) AVR-4-PW pulse width module

The modules are interconnected as shown in Fig. 4.

In the event of an instrument malfunction, it is most likely that the 1.0 A slow blow fuse or the main power fuse on the rear panel has blown. Replace if necessary. If the unit still does not function, it is most likely that some of the output switching elements (SL22T) may have failed due to an output short circuit condition or to a high duty cycle condition. The switching elements may be accessed by removing the cover plates on the bottom side of the instrument. The cover plate is removed by removing the two 2-56 Phillips screws. **NOTE:** First turn off the prime power. **CAUTION:** Briefly ground the SL22T tabs to discharge the 400 volts power supply potential. The elements may be removed from their sockets by means of a needle nosed pliers. The SL22T is a selected VMOS power transistor in a TO 220 package and may be checked on a curve tracer. If defective, replacement units should be ordered directly from Avtech. When replacing the SL22T switching elements, take care to insure that the short lead (of the three leads) is adjacent to the black dot on the chassis. If the switching elements are not defective, then the four Phillips screws on the back panel should be removed. The top cover may then be slid off and the operation of the clock and power supply modules checked. The clock module is functioning properly if:

- a) 0.1 usec TTL level outputs are observed at pins 2 and 3.
- b) The PRF of the outputs can be varied over the range of 2 Hz to 20 KHz using the PRF controls.
- c) The relative delay between the pin 2 and 3 outputs can be varied by at least 1 usec by the DELAY control.

The sealed clock module must be returned to Avtech for repair or replacement if the above conditions are not observed.

Schroff

06.18.90

1. The first part of the report is devoted to a description of the work done during the period from the 1st of January to the 31st of December 1989. It is divided into two main sections: a) a general survey of the work done and b) a detailed account of the results obtained in the various fields of research.

2. In the first section, the general survey, the following points are mentioned: a) the number of persons employed in the Institute during the year; b) the number of persons who have been admitted to the Institute during the year; c) the number of persons who have left the Institute during the year; d) the number of persons who have been promoted during the year; e) the number of persons who have been awarded degrees during the year; f) the number of persons who have been awarded honours during the year; g) the number of persons who have been awarded medals during the year; h) the number of persons who have been awarded titles during the year; i) the number of persons who have been awarded decorations during the year; j) the number of persons who have been awarded orders during the year; k) the number of persons who have been awarded medals of honour during the year; l) the number of persons who have been awarded titles of nobility during the year; m) the number of persons who have been awarded titles of nobility during the year; n) the number of persons who have been awarded titles of nobility during the year; o) the number of persons who have been awarded titles of nobility during the year; p) the number of persons who have been awarded titles of nobility during the year; q) the number of persons who have been awarded titles of nobility during the year; r) the number of persons who have been awarded titles of nobility during the year; s) the number of persons who have been awarded titles of nobility during the year; t) the number of persons who have been awarded titles of nobility during the year; u) the number of persons who have been awarded titles of nobility during the year; v) the number of persons who have been awarded titles of nobility during the year; w) the number of persons who have been awarded titles of nobility during the year; x) the number of persons who have been awarded titles of nobility during the year; y) the number of persons who have been awarded titles of nobility during the year; z) the number of persons who have been awarded titles of nobility during the year.