

AVTECH ELECTROSYSTEMS LTD.

NANOSECOND WAVEFORM ELECTRONICS
ENGINEERING . MANUFACTURING

□ P.O. BOX 265
OGDENSBURG
NEW YORK
13669
(315) 472.5270

BOX 5120 STN. "F"
OTTAWA, ONTARIO
CANADA K2C 3H4
Y (613) 226-5772
TELEX 053-4591

INSTRUCTIONS

MODEL AVR-4A-PW-PS-N-CU1 PULSE GENERATOR

S.N.:

WARRANTY

Avtech Electrosystems Ltd. warrants products of its manufacture to be free from defects in material and workmanship under conditions of normal use. If, within one year after delivery to the original owner, and after prepaid return by the original owner, this Avtech product is found to be defective, Avtech shall at its option repair or replace said defective item. This warranty does not apply to units which have been disassembled, modified or subjected to conditions exceeding the applicable specifications or ratings. This warranty is the extent of the obligation or liability assumed by Avtech with respect to this product and no other warranty or guarantee is either expressed or implied.

A.

TEST ARRANGEMENT

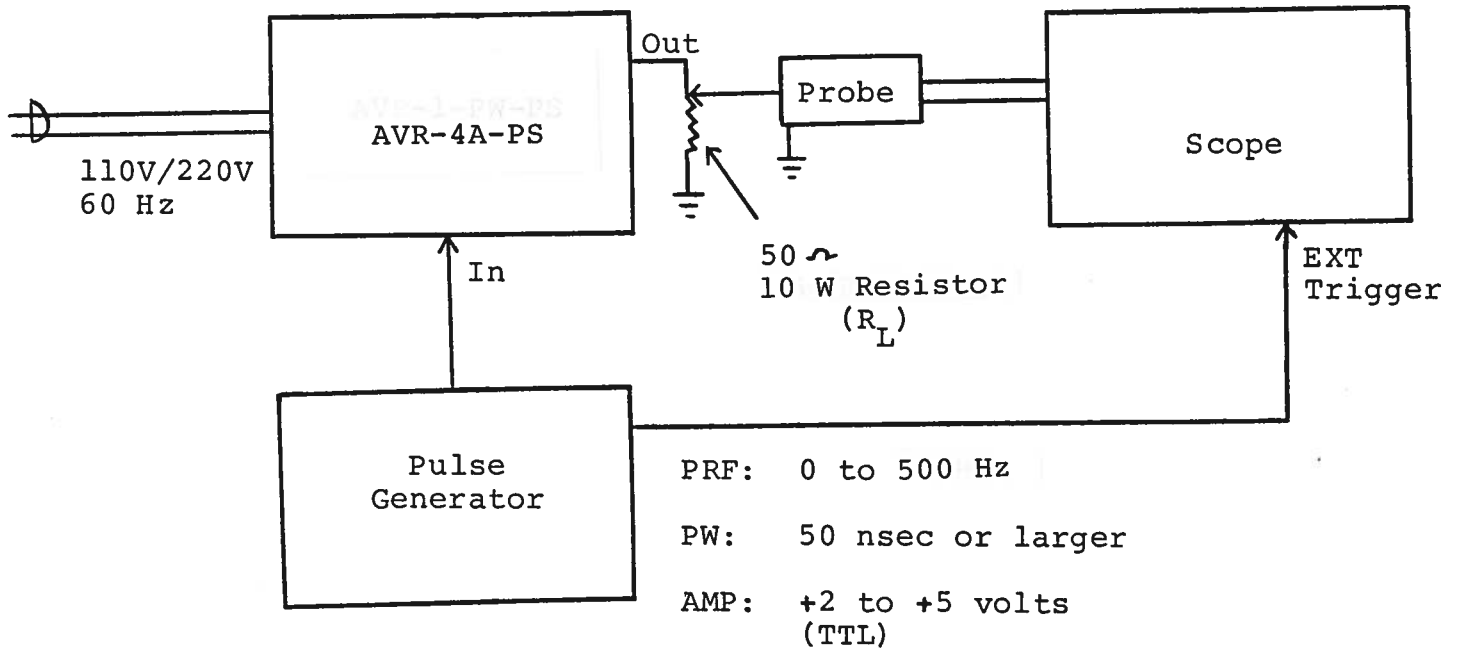

GENERAL OPERATING INSTRUCTIONS

- 1) The equipment should be connected in the general fashion shown above. Since the AVR unit provides an output pulse rise time as low as 20 nsec a fast oscilloscope (at least 50 MHz and preferably 200 MHz) should be used to display the waveform. Also, if a load of other than 50 ohm is employed, the length of coaxial cable between the AVR unit and the load should not exceed about 10 feet or the output waveform may be degraded by the resulting reflections.
- 2) The output PRF is equal to the input trigger pulse PRF.
- 3) The output pulse width is controlled by the one turn PW control.
- 4) The output amplitude is controlled by the one turn AMP control.
- 5) The maximum PRF or duty cycle must not be exceeded. Under simultaneous conditions of wide pulse width, high PRF and high load current, the bias voltage applied to the output power stage decreases and as a result the attainable output peak voltage decreases to less than 500 volts. Under conditions of severe loading the rear panel 0.1A fuse may blow or the output stage may be damaged. The output switching elements may be replaced following the instructions in the REPAIR section.

C.

SYSTEM BLOCK DIAGRAM AND REPAIR PROCEDURE

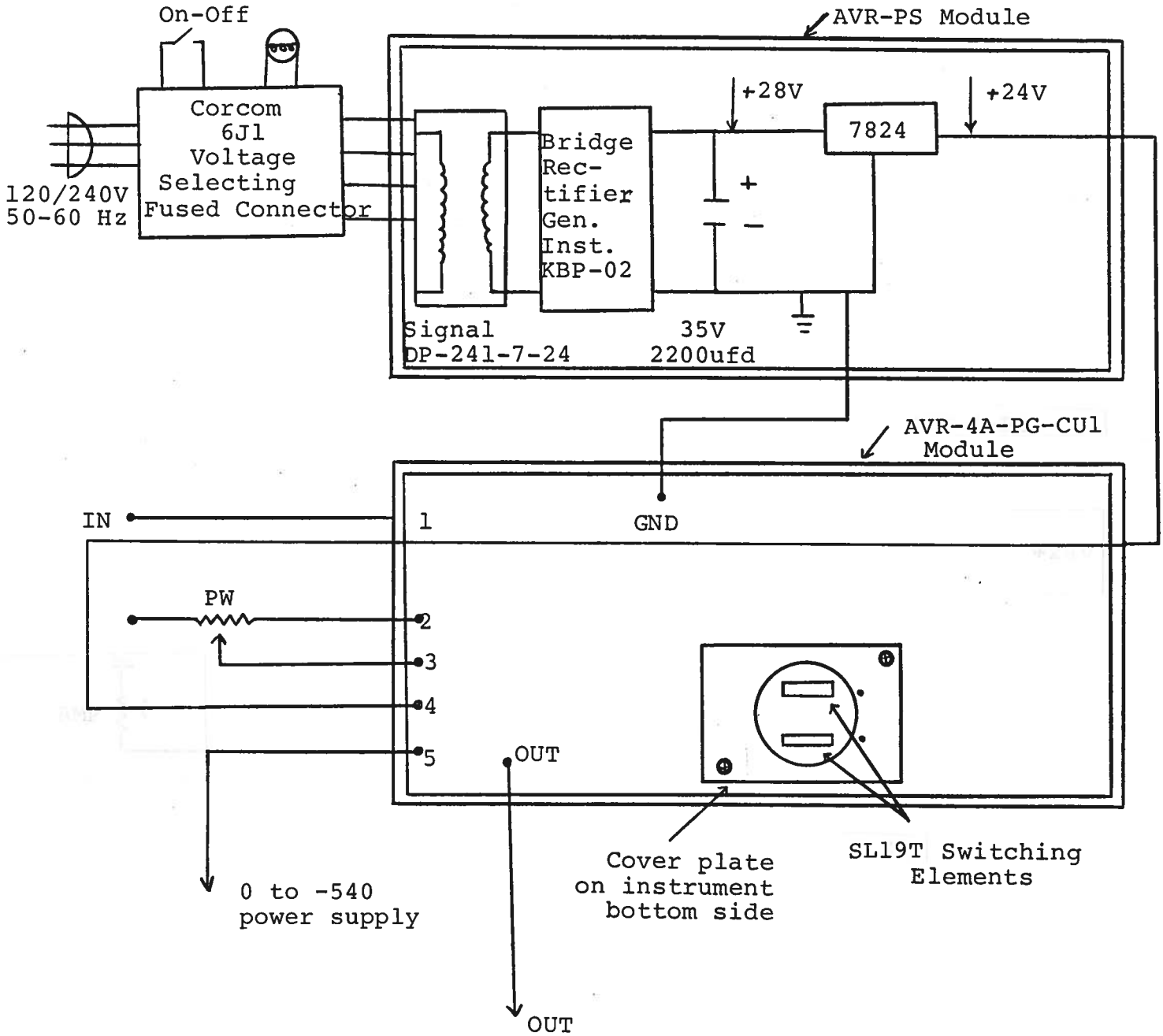

AVR 540 POWER SUPPLY

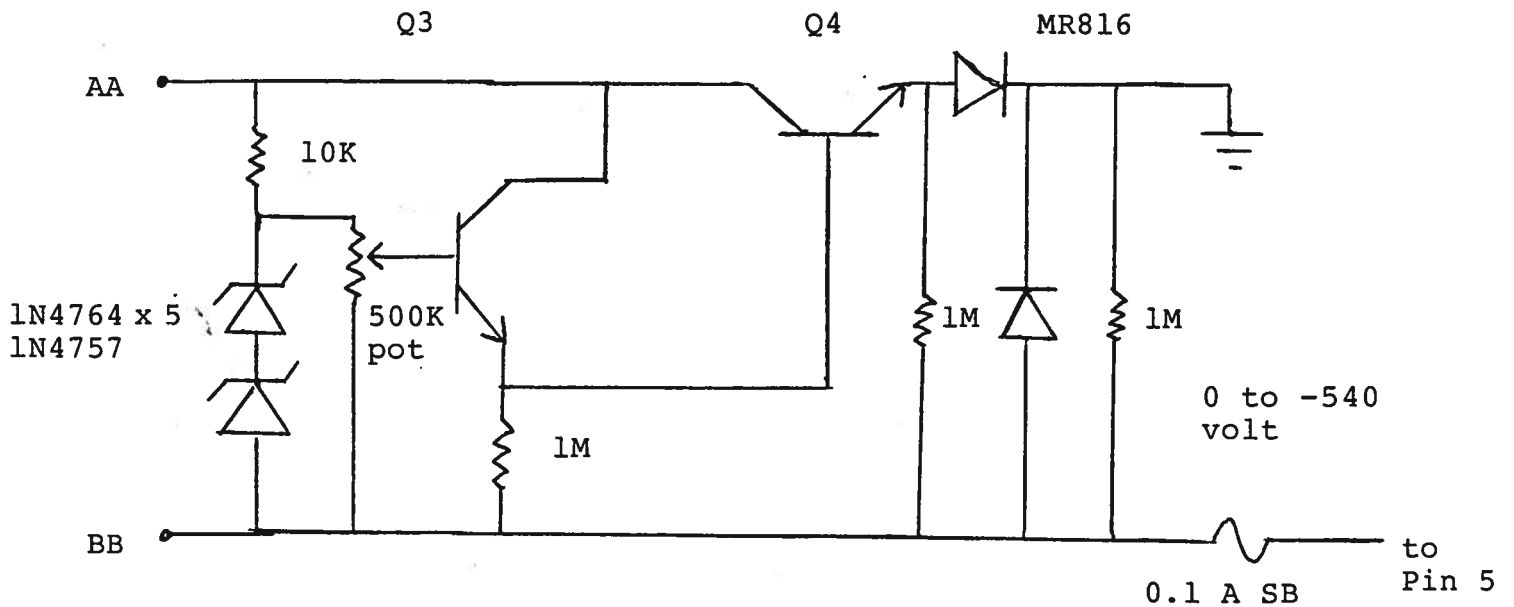
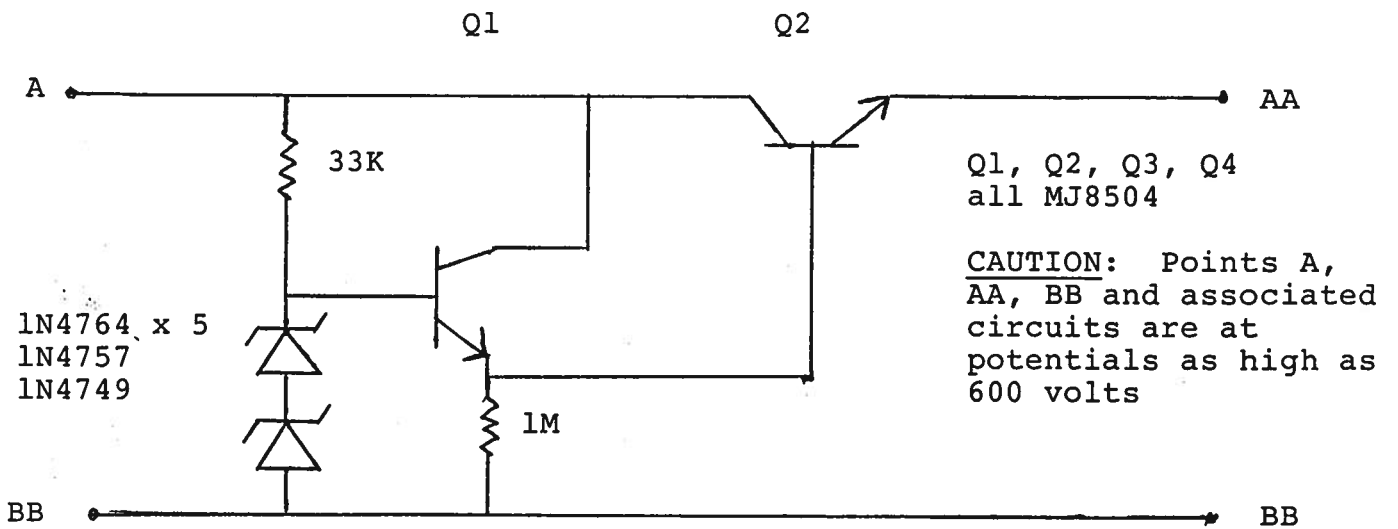
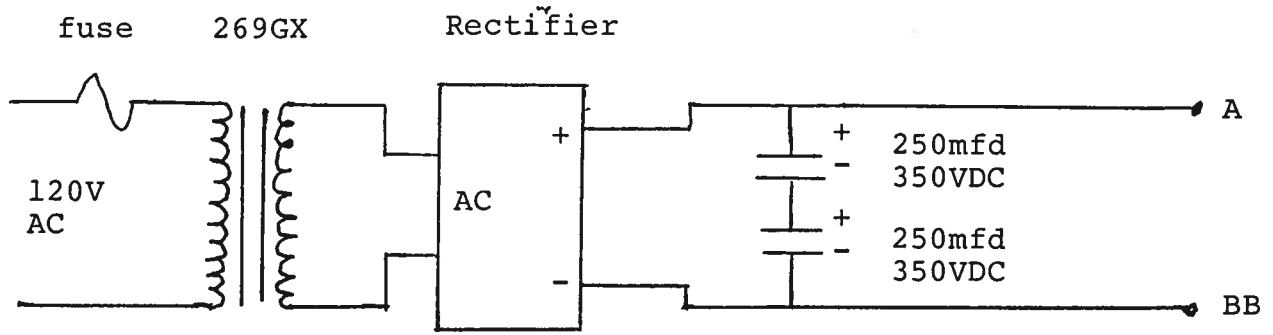

SYSTEM DESCRIPTION AND REPAIR PROCEDURE

The AVR-4-PS consists of the following basic modules:

- 1) AVR-4-PW-PG pulse generator module
- 2) 24V power supply module
- 3) 0 to 540 volts power supply module

The modules are interconnected as shown in Fig. 4.

In the event of an instrument malfunction, it is most likely that the 0.1 A slow blow fuse or the main power fuse on the rear panel has blown. Replace if necessary. If the unit still does not function, it is most likely that some of the output switching elements (SL19T) may have failed due to an output short circuit condition or to a high duty cycle condition. The switching elements may be accessed by removing the cover plate on the bottom side of the instrument. The cover plate is removed by removing the two 2-56 Phillips screws. NOTE: First turn off the prime power. CAUTION: Briefly ground the SL19T tabs to discharge the 540 volts power supply potential. The elements may be removed from their sockets by means of a needle nosed pliers after removing the four counter sunk 2-56 Phillips screws which attach the small aluminum heat sinks to the body of the instrument. The SL19T is a selected VMOS power transistor in a TO 220 packages and may be checked on a curve tracer. If defective, replacement units should be ordered directly from Avtech. When replacing the SL19T switching elements, take care to insure that the short lead (of the three leads) is adjacent to the back of the chassis. (See following Fig.). The SL19T elements are electrically isolated from the small aluminum heat sinks but are bonded to the heat sinks using WAKEFIELD TYPE 155 HEAT SINK ADHESIVE.

CAUTION: Potentials as high as 600 volts are present inside the instrument so extreme caution should be exercised if the instrument cover is removed.

SL19T HEAT SINKING

BACK

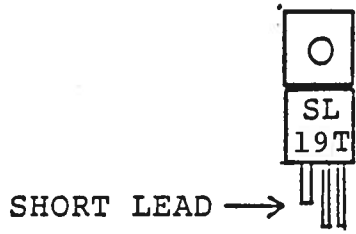
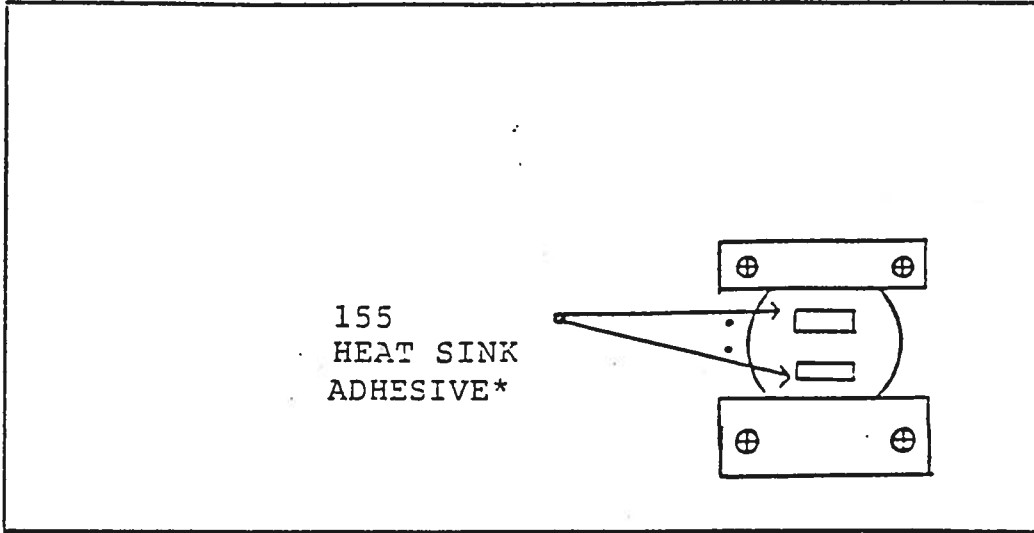

Schroff

10.27.88

11

