

# AVTECH ELECTROSYSTEMS LTD.

NANOSECOND WAVEFORM ELECTRONICS  
ENGINEERING - MANUFACTURING

□ P.O. BOX 265  
OGDENSBURG  
NEW YORK  
13669  
(315) 472-5270

BOX 5120, STN. "F"  
OTTAWA, ONTARIO  
CANADA K2C 3H4  
TEL: (613) 226-5772  
FAX: (613) 226-2802  
TELEX: 053-4591

## INSTRUCTIONS

MODEL AVR-4B-PW-C-PN-OU1 PULSE GENERATOR

S.N.:

## WARRANTY

Avtech Electrosystems Ltd. warrants products of its manufacture to be free from defects in material and workmanship under conditions of normal use. If, within one year after delivery to the original owner, and after prepaid return by the original owner, this Avtech product is found to be defective, Avtech shall at its option repair or replace said defective item. This warranty does not apply to units which have been disassembled, modified or subjected to conditions exceeding the applicable specifications or ratings. This warranty is the extent of the obligation or liability assumed by Avtech with respect to this product and no other warranty or guarantee is either expressed or implied.

Fig. 1

PULSE GENERATOR TEST ARRANGEMENT

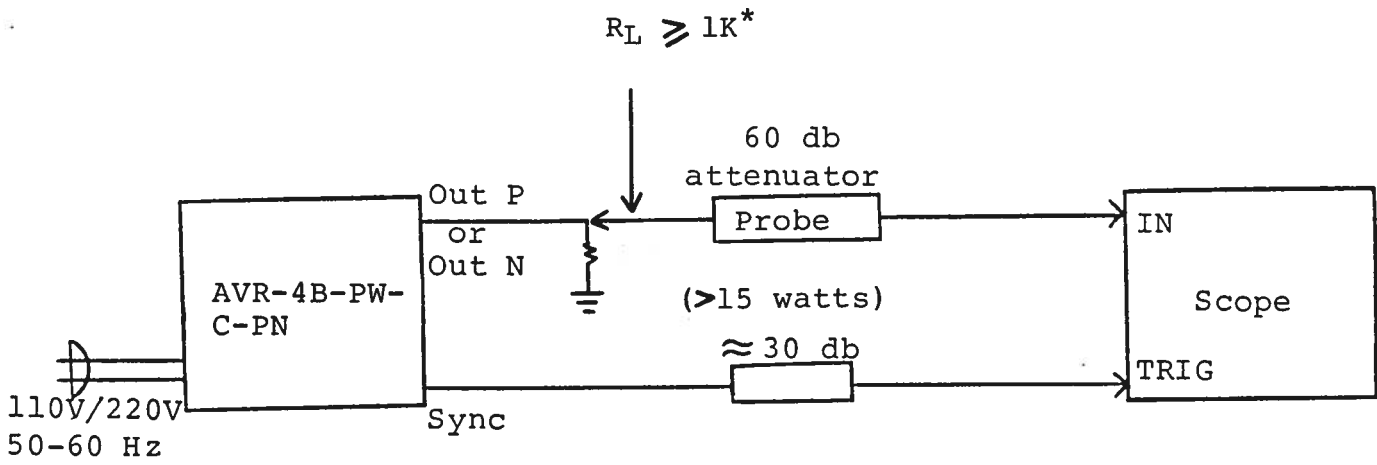

\*  $R_L$  as low as 50 ohm may be used by reducing max duty cycle by 50%

Notes:

- 1) The bandwidth capability of components and instruments used to display the pulse generator output signal (attenuators, cables, connectors, etc.) should exceed 100 MHz.
- 2) The sync output channel provides TTL level signals. To avoid overdriving the TRIG input channel of some scopes, a 30 db attenuator should be placed at the input to the scope trigger channel.
- 3) The output pulse widths for the positive and negative outputs are controlled by means of the front panel one turn PW control and by the PW RANGE control. The minimum and maximum PW for each range and the corresponding maximum PRF are as follows. Note that the unit may fail if operated at duty cycles exceeding the above.

	PW min	PW max
Range 1	0.1 usec PRF max 1 KHz	1.0 usec PRF max 1 KHz
Range 2	1.0 usec PRF max 1 KHz	10 usec PRF max 500 Hz
Range 3	10 usec PRF max 500 Hz	100 usec PRF max 50 Hz

To voltage control the output pulse width within each range, remove the jumper wire between banana plugs A and B on the back panel and apply 0 to +10V to connector B ( $R_{IN} \geq 10K$ ). (option).

- 4) To obtain a stable output display the PRF control on the front panel should be set mid range. The front panel TRIG toggle switch should be in the INT position. The DELAY controls and the scope triggering controls are then adjusted to obtain a stable output. The scope may then be used to set the desired PRF by rotating the PRF and PRF FINE controls.
- 5) The output pulse amplitudes for the positive and negative outputs are controlled by means of the front panel one turn AMP control. To voltage control the output amplitude, remove the jumper wire between banana plugs A and B on the back panel and apply 0 to +10V to connector B ( $R_{IN} \geq 10K$ ). (option).

- 6) An external clock may be used to control the output PRF of the AVR unit by setting the front panel TRIG toggle switch in the EXT position and applying a 0.2 usec (approx.) TTL level pulse to the TRIG BNC connector input. For operation in this mode, the scope time base must also be triggered by the external clock rather than from the SYNC output.
- 7) The AVR-4-PW features an output impedance of the order of several ohms (rather than 50 ohms). The following consequences of this feature should be noted:
  - a) When used to switch some semiconductor devices (eg. bipolar and VMOS power transistors), the AVR unit will yield much faster switching times than those provided by 50 ohm pulse generators.
  - b) The AVR unit will safely operate in to load impedances in the range of 50 ohms to an open circuit. However, the fall time may degrade for load impedances higher than fifty ohms.
  - c) The AVR unit may be effectively converted to a fifty ohm output impedance generator by placing a fifty ohm 1/2 watt carbon composition resistor in series with the output of the unit and the load. The maximum available load voltage will then decrease to 200 volts (from 400 volts).
  - d) The output switching elements may fail if the unit is inadvertently operated into a short circuit. The switching elements are easily replaced in the field following the procedure outlined in the REPAIR Section.
- 8) CAUTION: The output stage is protected against overload condition by a 0.5 A slow blow fuse on the main frame back panel. However, the output switching elements (SL18T) may fail if the unit is triggered at a PRF exceeding 1 KHz or at duty cycles resulting in an average output power in excess of 16 watts. Heating and subsequent likely failure of the output stage is reduced if the following action is taken where possible:
  - a) PRF is kept to a minimum, ie. operate in a low PRF range when possible rather than in a high PRF range.
  - b) Keep the output PW to a minimum.
- 9) The unit can be converted from 110 to 220V 50-60 Hz operation by adjusting the voltage selector card in the rear panel fused voltage selector cable connector assembly.

Fig. 2

FRONT PANEL CONTROLS

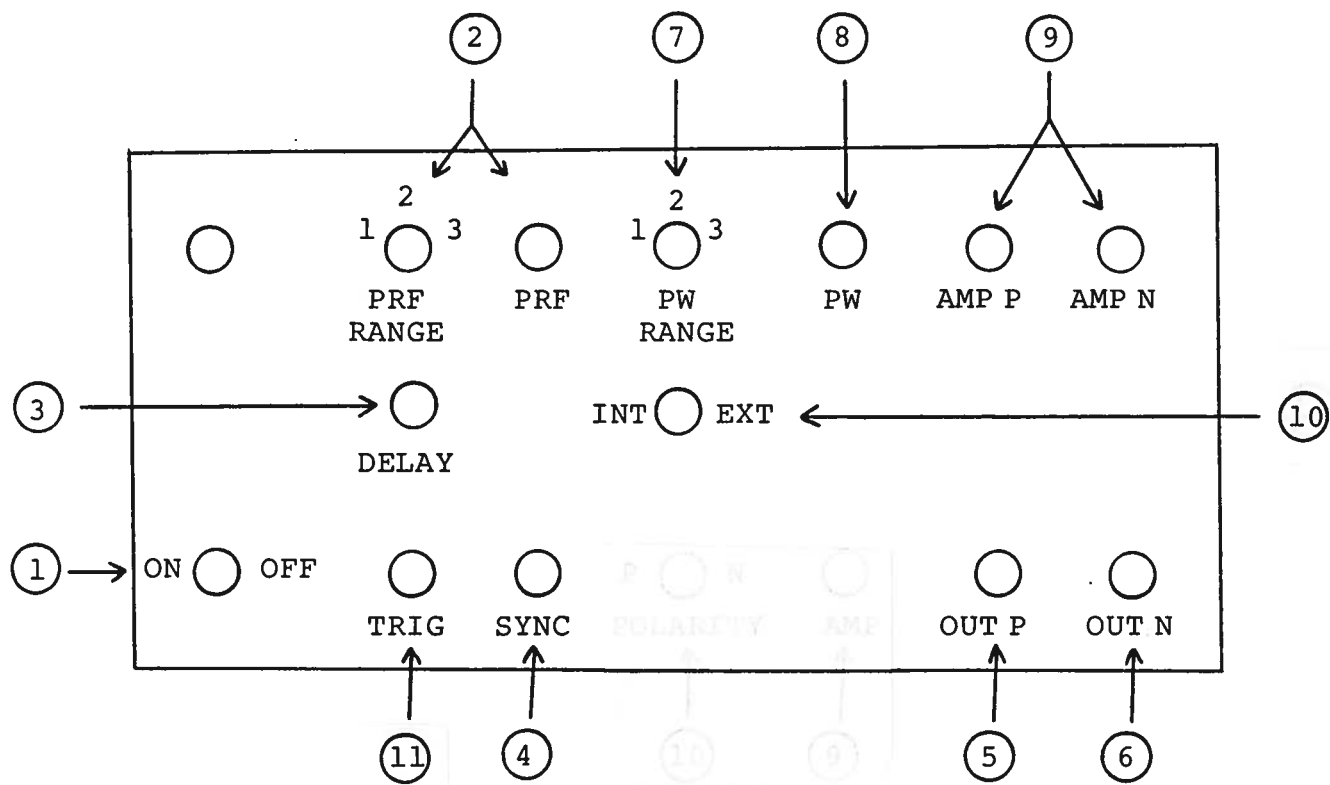

- (1) ON-OFF Switch. Applies basic prime power to all stages.
- (2) PRF Control. Varies PRF from 10 Hz to 1 KHz as follows:
 

Range 1	10 Hz	50 Hz
Range 2	10 Hz to 300 Hz	
Range 3	10 Hz to 1 KHz	
- (3) DELAY Control. Controls the relative delay between the reference output pulse provided at the SYNC output (4) the main output (5) and (6). This delay is variable over the range of 0 to about 1.0 usec.
- (4) SYNC Output. This output precedes the main output (5) and (6) and is used to trigger the scope time base. The output is a TTL level 100 nsec (approx.) pulse capable of driving a fifty ohm load.
- (5) OUT N Connector. BNC connector provides output to a fifty ohm load.
- (6) OUT P Connector. BNC connector provides output to a fifty ohm load.
- (7) PW Control. A one turn control and 3 position range switch which varies the positive output pulse width from 0.1 usec to 10 usec. The minimum and maximum PW for each range and the corresponding maximum PRF are as follows. Note that the unit may fail if operated at duty cycles exceeding the above.

	PW min	PW max
Range 1	0.1 usec PRF max 1 KHz	1.0 usec PRF max 1 KHz
Range 2	1.0 usec PRF max 1 KHz	10 usec PRF max 500 Hz
Range 3	10 usec PRF max 500 Hz	100 usec PRF max 50 Hz

- (9) AMP Control. A one turn control which varies the output pulse amplitude from 0 to 400 V to a fifty ohm load.
- (10) EXT-INT Control. With this toggle switch in the INT position, the PRF of the AVR unit is controlled via an internal clock which in turn is controlled by the PRF and PRF FINE controls. With the toggle switch in the EXT position, the AVR unit requires a 0.2 usec TTL level pulse applied at the TRIG input in order to trigger the output stages. In addition, in this mode, the scope time base must be triggered by the external trigger source.

- (11) TRIG Input. The external trigger signal is applied at this input when the EXT-INT toggle switch is in the EXT position.



Fig. 3

BACK PANEL CONTROLS

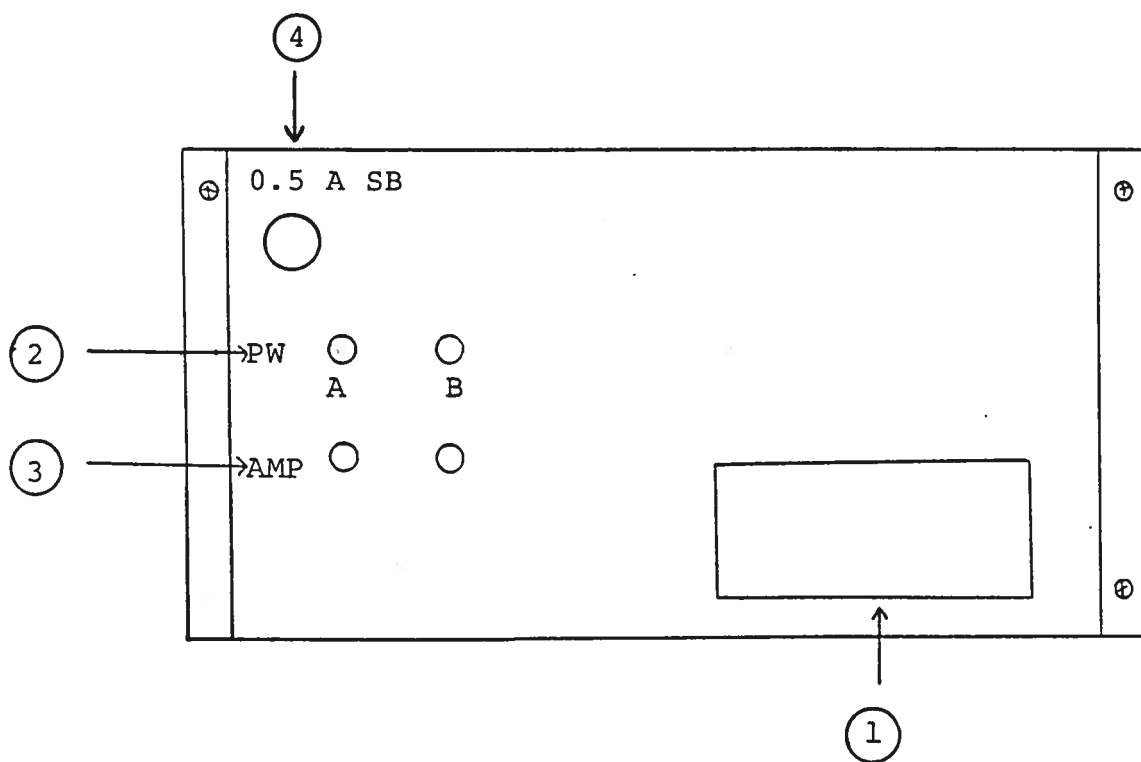

- (1) FUSED CONNECTOR, VOLTAGE SELECTOR. The detachable power cord is connected at this point. In addition, the removable cord is adjusted to select the desired input operating voltage. The unit also contains the main power fuse (0.5 A SB).
- (2) To voltage control the output pulse width, remove the jumper wire between banana plugs A and B and apply 0 to +10V to connector B ( $R_{IN} \geq 10K$ ). (option).
- (3) To voltage control the output amplitude, remove the jumper wire between banana plugs A and B and apply 0 to +10V to connector B ( $R_{IN} \geq 10K$ ). (option).
- (4) 0.5 A SB. Protects output stage against overload condition.

Fig. 4

AVR-4B-PW-PN-C BLOCK DIAGRAM

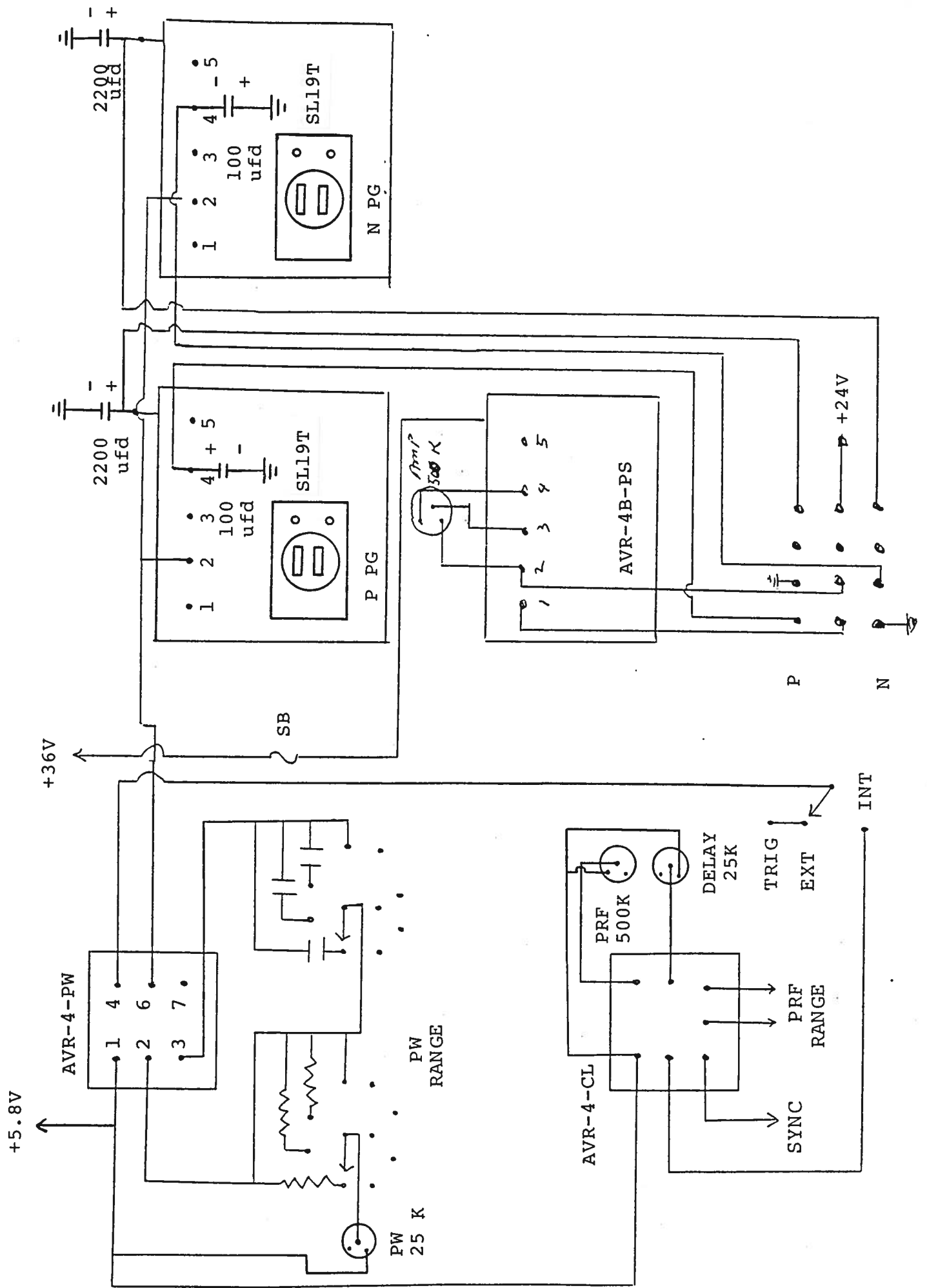
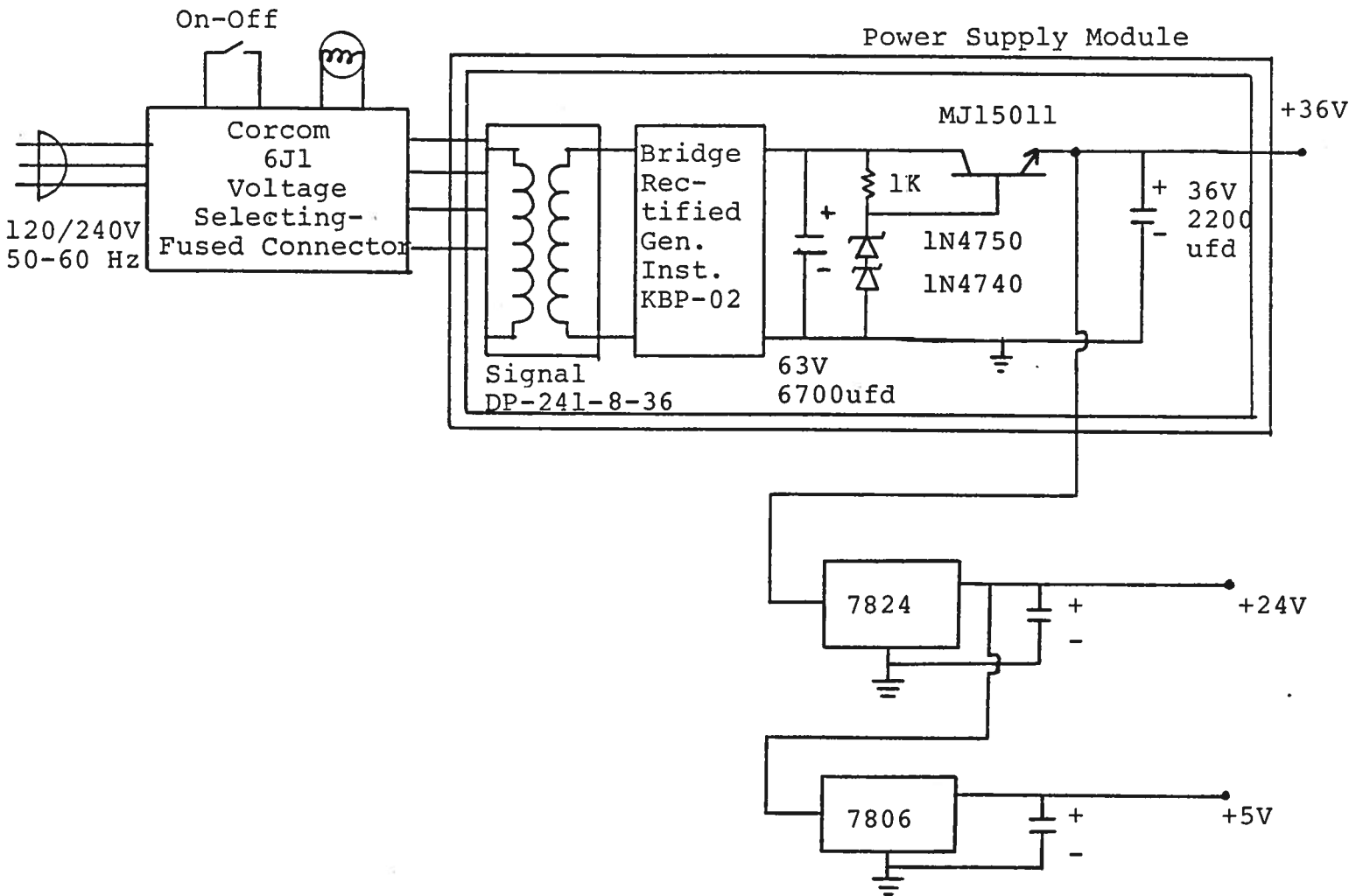

Fig. 4a

POWER SUPPLY



## SYSTEM DESCRIPTION AND REPAIR PROCEDURE

The AVR-4-PW-C-PN consists of the following basic modules:

- 1) AVR-4-PW-PG pulse generator modules (-P and -N)
- 2) AVR-4-CL clock module
- 3) +36V, +24V, +5.8V power supply board
- 4) AVR-4-PS power supply module
- 5) AVR-4-PW pulse width module

The modules are interconnected as shown in Fig. 4.

In the event of an instrument malfunction, it is most likely that the 0.5 A slow blow fuse or the main power fuse on the rear panel has blown. Replace if necessary. If the unit still does not function, it is most likely that some of the output switching elements (SL19T) may have failed due to an output short circuit condition or to a high duty cycle condition. The switching elements may be accessed by removing the cover plates on the bottom side of the instrument. The cover plate is removed by removing the two 2-56 Phillips screws. NOTE: First turn off the prime power. CAUTION: Briefly ground the SL19T tabs to discharge the 400 volts power supply potential. The elements may be removed from their sockets by means of a needle nosed pliers after removing the four counter sunk 2-56 Phillips screws which attach the small aluminum heat sinks to the body of the instrument. The SL19T is a selected VMOS power transistor in a TO 220 package and may be checked on a curve tracer. If defective, replacement units should be ordered directly from Avtech. When replacing the SL19T switching elements, take care to insure that the short lead (of the three leads) is adjacent to the back of the chassis. (See following Fig.). The SL19T elements are electrically isolated from the small aluminum heat sinks but are bonded to the heat sinks using WAKEFIELD TYPE 155 HEAT SINK ADHESIVE. If the switching elements are not defective, then the four Phillips screws on the back panel should be removed. The top cover may then be slid off and the operation of the clock and power supply modules checked. The clock module is functioning properly if:

- a) 0.1 usec TTL level outputs are observed at pins 2 and 3.
- b) The PRF of the outputs can be varied over the range of 10 Hz to 1 KHz using the PRF controls.
- c) The relative delay between the pin 2 and 3 outputs can be varied by at least 1 nsec by the DELAY control.

The sealed clock module must be returned to Avtech for repair or replacement if the above conditions are not observed.

SL19T HEAT SINKING

BACK

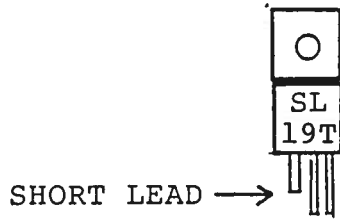
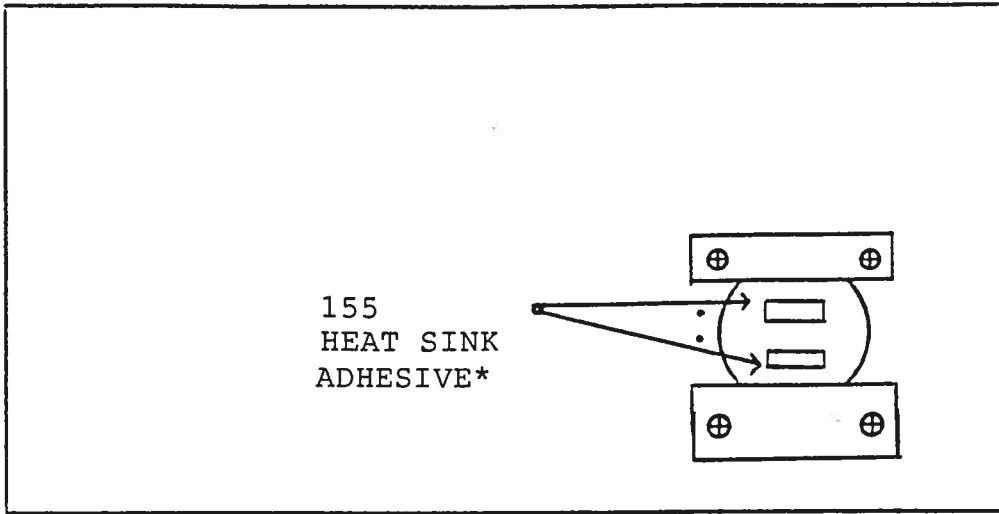

Schroff

06.22.89

-EW

-EA