



AVTECH ELECTROSYSTEMS LTD.
NANOSECOND WAVEFORM ELECTRONICS

P.O. BOX 265
OGDENSBURG, NY
U.S.A. 13669-0265
TEL: (315) 472-5270
FAX: (613) 226-2802

BOX 5120 STN. F
OTTAWA, ONTARIO
CANADA K2C 3H4
TEL: (613) 226-5772
FAX: (613) 226-2802

INSTRUCTIONS

MODEL AVR-5B-PW-PS PULSE GENERATOR

S.N. :

WARRANTY

Avtech Electrosystems Ltd. warrants products of its manufacture to be free from defects in material and workmanship under conditions of normal use. If, within one year after delivery to the original owner, and after prepaid return by the original owner, this Avtech product is found to be defective, Avtech shall at its option repair or replace said defective item. This warranty does not apply to units which have been disassembled, modified or subjected to conditions exceeding the applicable specifications or ratings. This warranty is the extent of the obligation or liability assumed by Avtech with respect to this product and no other warranty or guarantee is either expressed or implied.

Fig. 1

PULSE GENERATOR TEST ARRANGEMENT

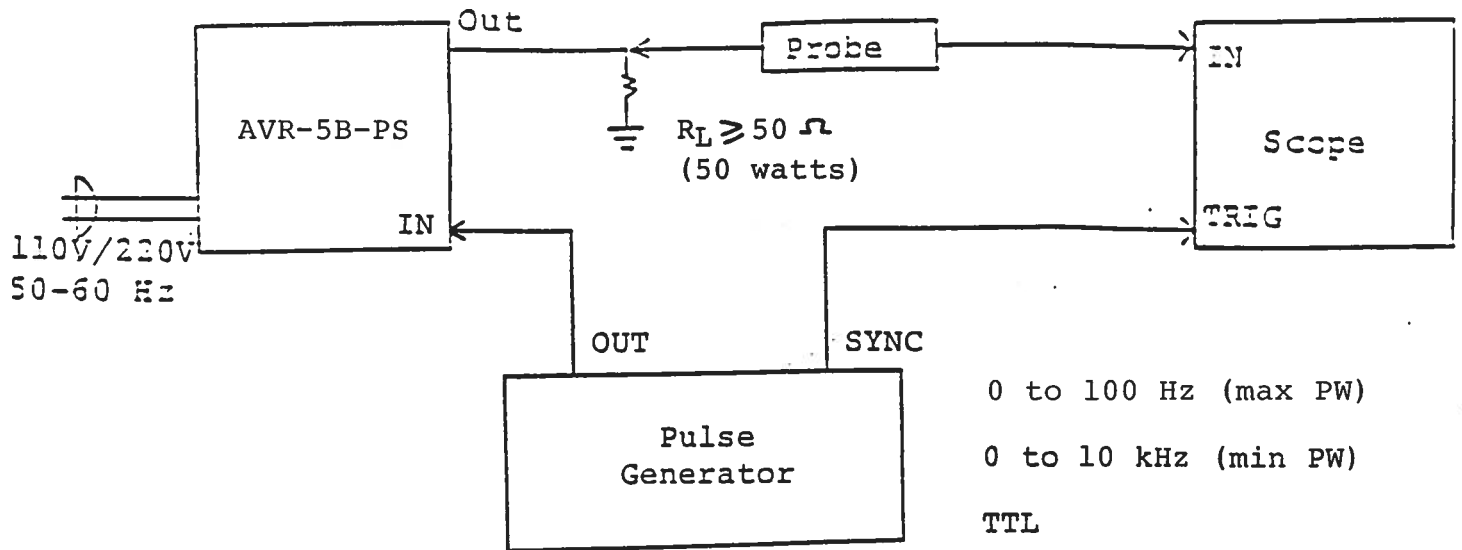

Notes:

- 1) The bandwidth capability of components and instruments used to display the pulse generator output signal (attenuators, cables, connectors, etc.) should exceed 100 MHz.
- 2) With the AB mode switch in the A position, the output pulse width is controlled by the 3 position PW range switch and the one turn PW control (10 turn control for units with the -PWT option). The minimum and maximum PW for each range and the corresponding maximum PRF are as follows. Note that the unit may fail if operated at duty cycles exceeding the above.

	PW min	PW max
1)	0.1 us PRF max 10 kHz	1.0 us PRF max 10 kHz
2)	1.0 us PRF max 10 kHz	10 us PRF max 1 kHz
3)	10 us PRF max 1 kHz	100 us PRF max 100 Hz

- 3) With the AB mode switch in the B position, the output pulse width is equal to the input trigger pulse width.
- 4) The output pulse amplitude is controlled by means of the front panel one turn AMP control (10 turn control for units with the -AT option). CAUTION: The AMP control should be rotated slowly (particularly when rotating CCW) so as to avoid over-stressing of the output stage.
- 5) The monitor output port provides an attenuated (x100) coincident replica to the main output (the monitor port must be terminated in 50 Ohms).
- 6) The AVR-5-PS features an output impedance of the order of several ohms (rather than 50 ohms). The following consequences of this feature should be noted:
 - a) When used to switch some semiconductor devices (eg. bipolar and VMOS power transistors), the AVR unit will yield much faster switching times than those provided by 50 ohm pulse generators.
 - b) The output switching elements may fail if the unit is inadvertently operated into a short circuit. The switching elements are easily replaced in the field following the procedure outlined in the REPAIR Section.

- 7) CAUTION: The output stage is protected against overload condition by a 2.0 A slow blow fuse on the main frame back panel. However, the output switching elements may fail if the unit is triggered at a PRF exceeding 10 kHz or at duty cycles resulting in an average output power in excess of 50 watts. Heating and subsequent likely failure of the output stage is reduced if the following action is taken where possible:
- a) PRF is kept to a minimum, ie. operate in a low PRF range when possible rather than in a high PRF range.
 - b) Keep the output PW to a minimum.
- 8) OVERLOAD INDICATOR. AVR-5 units with a serial number higher than 5600 are protected by an automatic overload protective circuit which controls the front panel overload light. If the unit is overloaded (by operating at an exceedingly high duty cycle or by operating into a short circuit), the protective circuit will turn the output of the instrument OFF and turn the indicator light ON. The light will stay ON (i.e. output OFF) for about 5 seconds after which the instrument will attempt to turn ON (i.e. light OFF) for about 1 second. If the overload condition persists, the instrument will turn OFF again (i.e. light ON) for another 5 seconds. If the overload condition has been removed, the instrument will turn on and resume normal operation. Overload conditions may be removed by:
- 1) Reducing PRF (i.e. switch to a lower range)
 - 2) Reducing pulse width (i.e. switch to a lower range)
 - 3) Removing output load short circuit (if any)
- 9) The unit can be converted from 110 to 220V 50-60 Hz operation by adjusting the voltage selector card in the rear panel fused voltage selector cable connector assembly.
- 10) For additional assistance:
- Tel: (613) 226-5772
Fax: (613) 226-2802

Fig. 2

FRONT PANEL CONTROLS

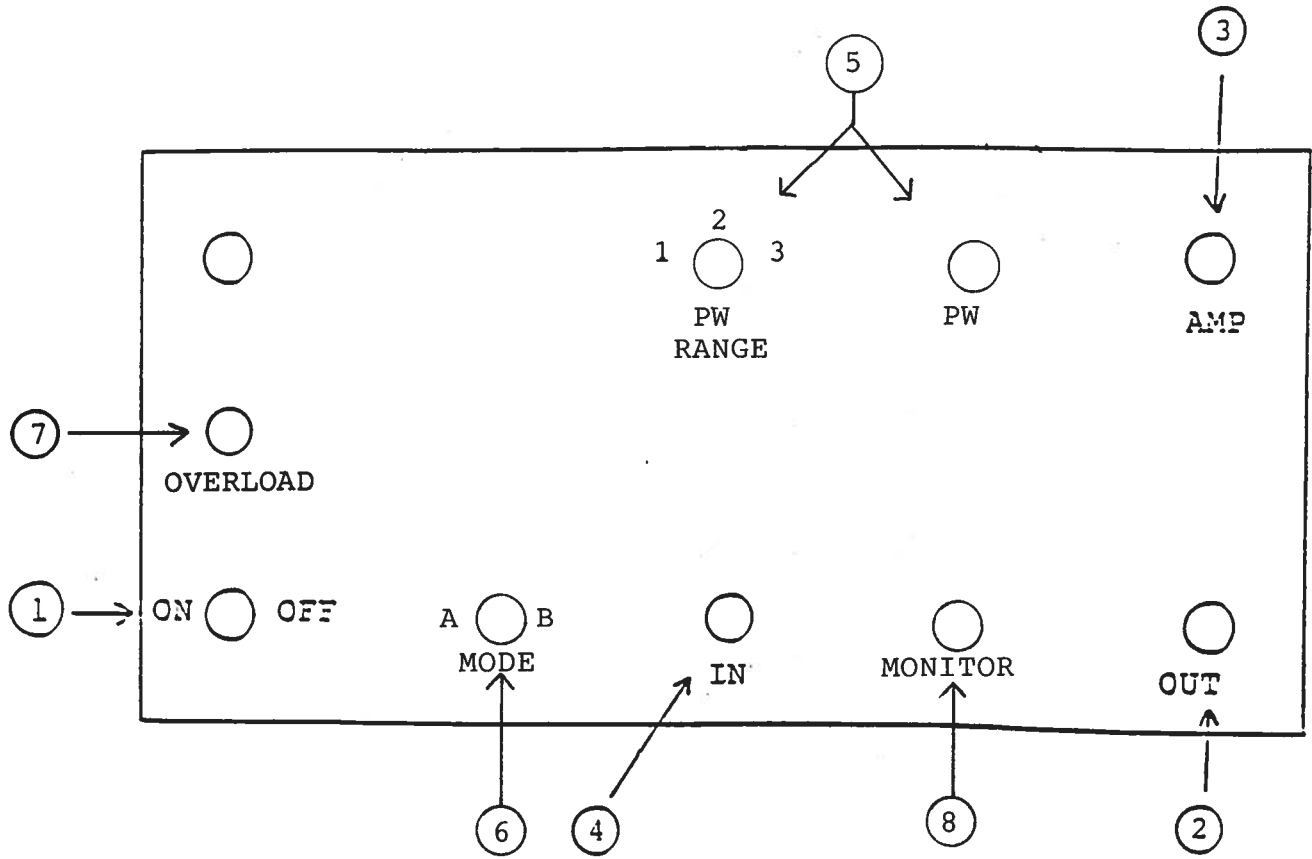

- (1) ON-OFF Switch. Applies basic prime power to all stages.
- (2) OUT Connector. N connector provides output to a 50 ohm load.
- (3) AMP Control. A one turn control which varies the output pulse amplitude from 0 to 500 V (ten turn control for -AT option units).
- (4) TRIG Input. The external trigger signal is applied at this input (TTL).
- (5) PW Control. A one turn control (ten turn control for -PWT option units) and 3 position range switch which varies the output pulse width from 0.1 usec to 100 usec. The minimum and maximum PW for each range and the corresponding maximum PRF are as follows. Note that the unit may fail if operated at duty cycles exceeding the above.

	PW min	PW max
Range 1	0.1 us PRF max 10 kHz	1.0 us PRF max 10 kHz
Range 2	1.0 us PRF max 10 kHz	10 us PRF max 1 kHz
Range 3	10 us PRF max 1 kHz	100 us PRF max 100 Hz

- (6) AB MODE. When switch is in the A position output pulse width is controlled by PW controls (5) while if switch is in the B position, the output pulse width equals the input trigger pulse width.
- (7) OVERLOAD INDICATOR. AVR-7 units with a serial number higher than 5600 are protected by an automatic overload protective circuit which controls the front panel overload light. If the unit is overloaded (by operating at an exceedingly high duty cycle or by operating into a short circuit), the protective circuit will turn the output of the instrument OFF and turn the indicator light ON. The light will stay ON (i.e. output OFF) for about 5 seconds after which the instrument will attempt to turn ON (i.e. light OFF) for about 1 second. If the overload condition persists, the instrument will turn OFF again (i.e. light ON) for another 5 seconds. If the overload condition has been removed, the instrument will turn on and resume normal operation. Overload conditions may be removed by:

- 1) Reducing PRF (i.e. switch to a lower range)
 - 2) Reducing pulse width (i.e. switch to a lower range)
 - 3) Removing output load short circuit (if any)
- (8) MONITOR. The monitor output provides an attenuated (x100) replica of the main output (to 50 Ohms).

Fig. 3

BACK PANEL CONTROLS

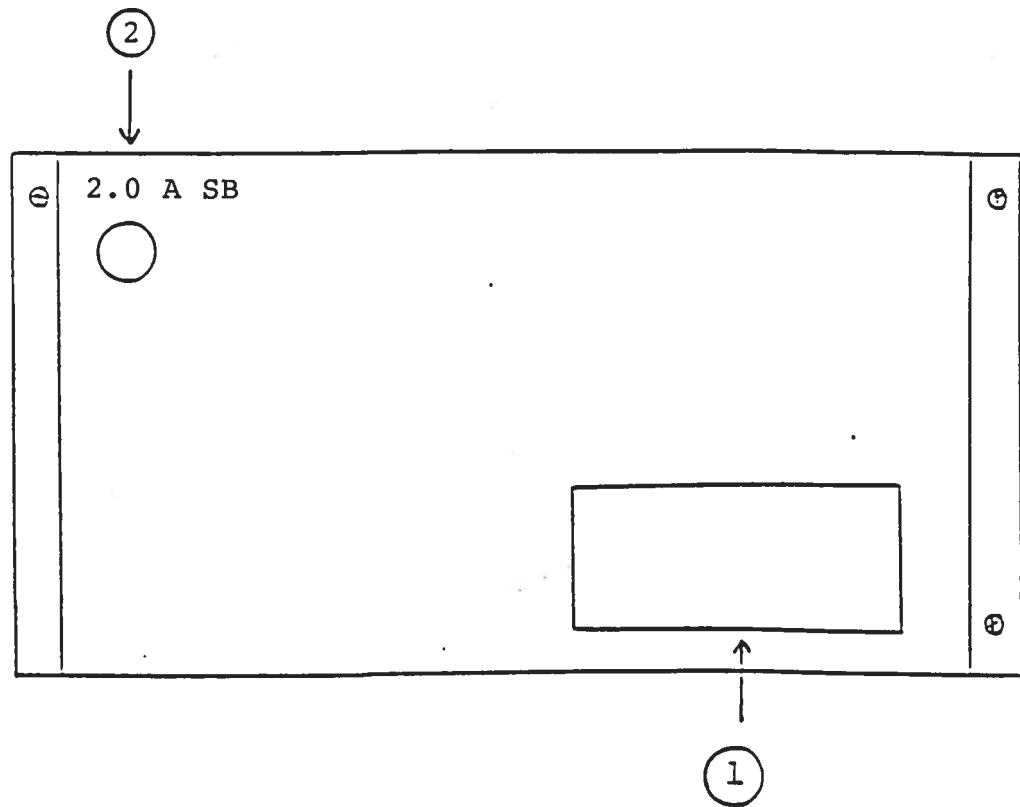

- (1) FUSED CONNECTOR, VOLTAGE SELECTOR. The detachable power cord is connected at this point. In addition, the removable cord is adjusted to select the desired input operating voltage. The unit also contains the main power fuse (1.0 A SB).
- (2) 2.0 A SB. Protects output stage against overload condition.

POWER SUPPLY

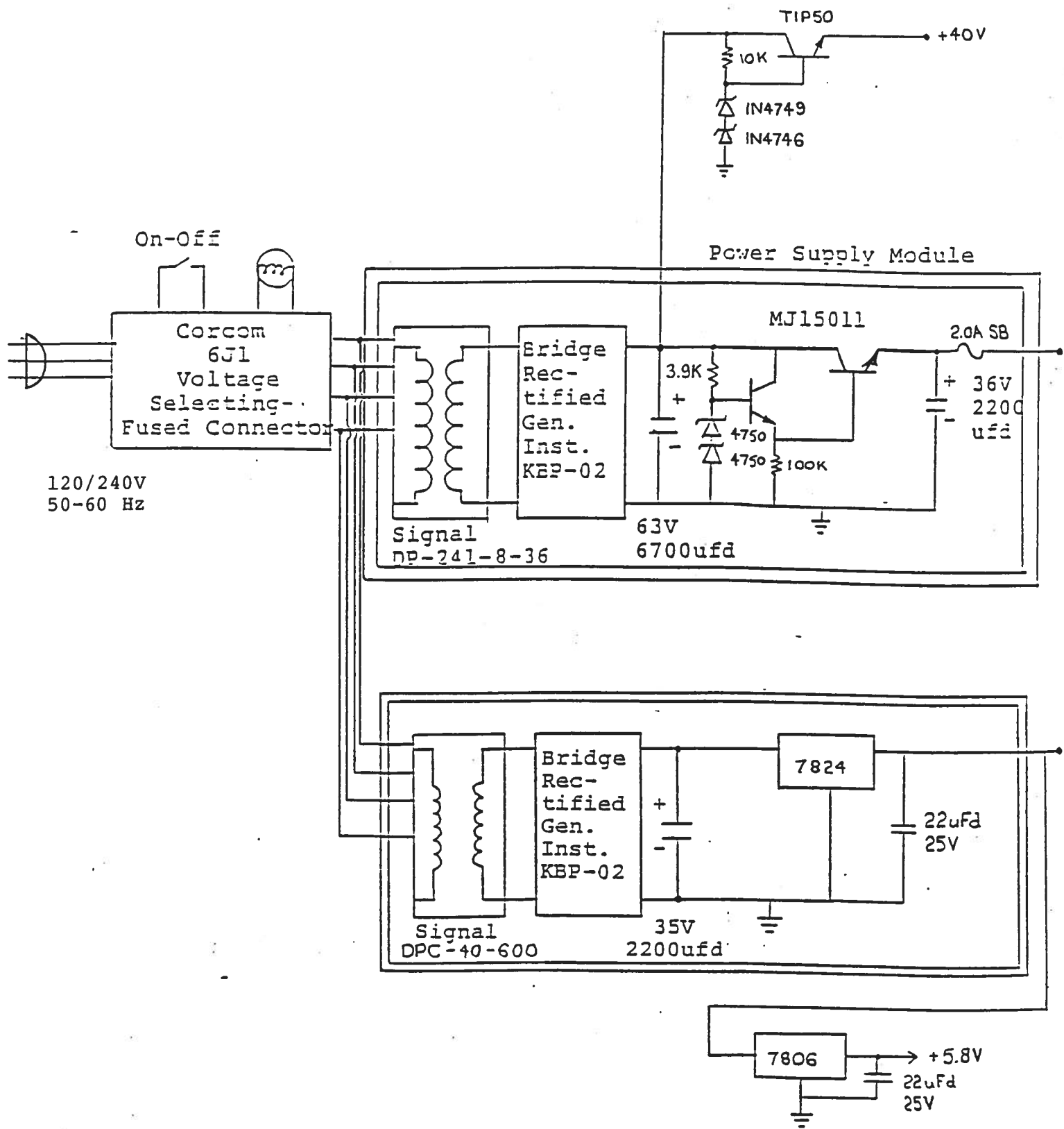

CAUTION!!

Points on this line are at a potential as high as 550 volts

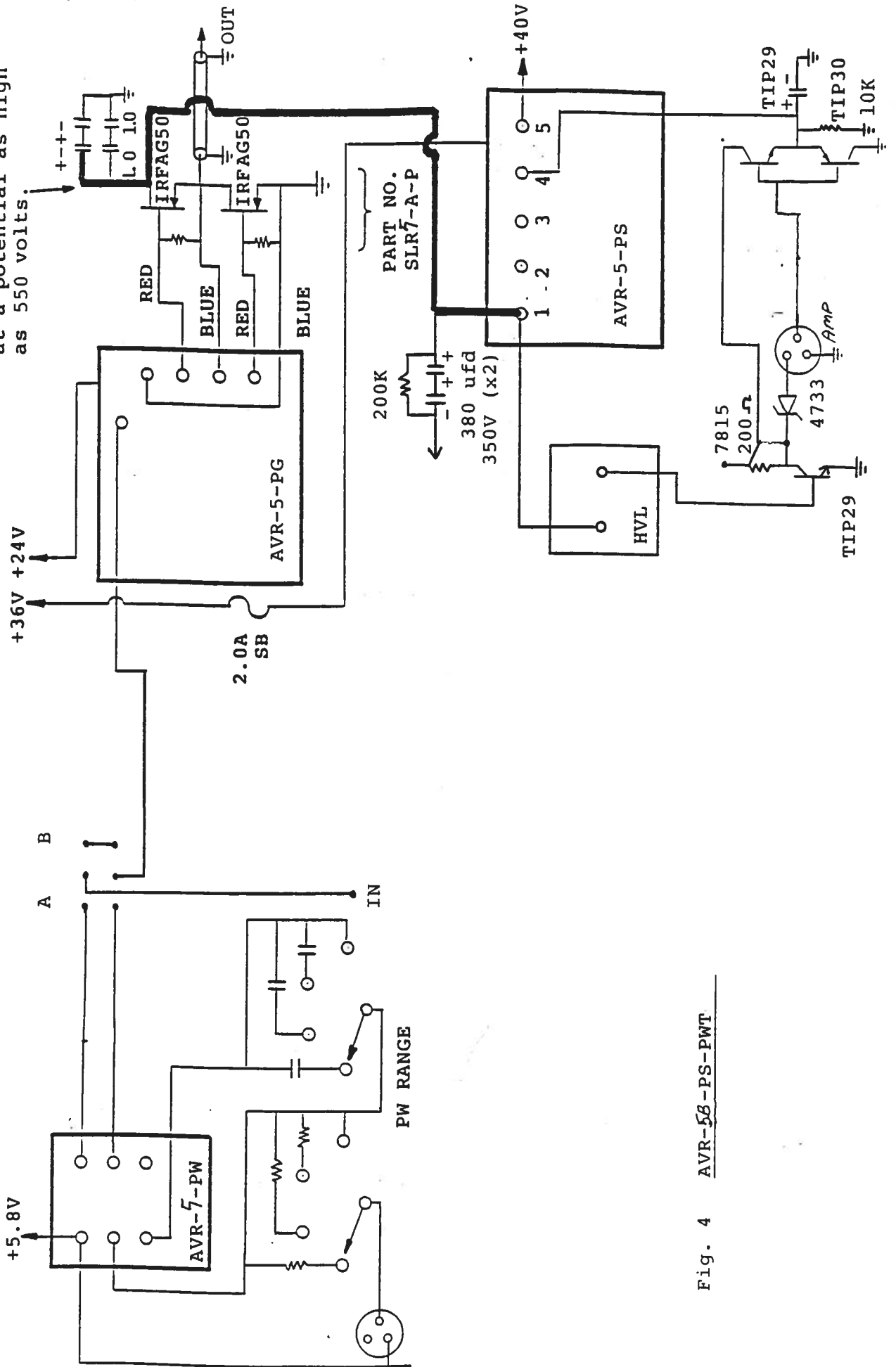

Fig. 4 AVR-56-PS-PWT

SYSTEM DESCRIPTION AND REPAIR PROCEDURE

CAUTION: Potentials as high as 550 volts DC are employed in the interior of this instrument so extreme caution must be exercised when attempting repairs. The following parts may be at high potential:

- a) Pin 2 of module AVR-5B-PG (including associated leads and capacitors and Part No. SLR5-A).
- b) Pin 1 on module AVR-5B-PS (and associated leads and capacitors).

The AVR-5B-PS consists of the following basic modules:

- 1) AVR-5B-PW-PG pulse generator module
- 2) AVR-5B-PS power supply module
- 3) AVR-5B-PW pulse width module

The modules are interconnected as shown in Fig. 4.

In the event of an instrument malfunction, it is most likely that the 2.0 A slow blow fuse or the main power fuse on the rear panel has blown. Replace if necessary. If the unit still does not function, it is most likely that some of the output switching elements (IRFAG50) may have failed due to an output short circuit condition or to a high duty cycle condition. The switching elements may be accessed by removing the top cover plate. The cover plate is removed by removing the 4 Phillips screws on the back panel. NOTE: First turn off the prime power. CAUTION: Thoroughly ground the IRFAG50 cases to discharge the 500 volts power supply potential. The IRFAG50 may be removed from the mounting bracket and checked on a curve tracer and replaced if necessary. AVTECH Part No. SLR5-A consists of the two transistors mounted on the bracket with insulating washers, 1 K resistors and output cable.

Schroff

08.24.92

- PWT

- AT

- M

- GEO2

- R4