



AVTECH ELECTROSYSTEMS LTD.

NANOSECOND WAVEFORM ELECTRONICS
SINCE 1975

□ P.O. BOX 265
OGDENSBURG, NY
U.S.A. 13669-0265
TEL: (315) 472-5270
FAX: (613) 226-2802

TEL: 1-800-265-6681
FAX: 1-800-561-1970

e-mail: info@avtechpulse.com
<http://www.avtechpulse.com>

□ P.O. BOX 5120 STN. F
OTTAWA, ONTARIO
CANADA K2C 3H4
TEL: (613) 226-5772
FAX: (613) 226-2802

INSTRUCTIONS

MODEL AVR-5B-PS-PN-EA-EW PULSE GENERATOR

S.N.:

WARRANTY

Avtech Electrosystems Ltd. warrants products of its manufacture to be free from defects in material and workmanship under conditions of normal use. If, within one year after delivery to the original owner, and after prepaid return by the original owner, this Avtech product is found to be defective, Avtech shall at its option repair or replace said defective item. This warranty does not apply to units which have been disassembled, modified or subjected to conditions exceeding the applicable specifications or ratings. This warranty is the extent of the obligation assumed by Avtech with respect to this product and no other warranty or guarantee is either expressed or implied.

TECHNICAL SUPPORT

Phone: 613-226-5772 or 1-800-265-6681

Fax: 613-226-2802 or 1-800-561-1970

E-mail: info@avtechpulse.com

World Wide Web: <http://www.avtechpulse.com>

TABLE OF CONTENTS

WARRANTY	2
TABLE OF CONTENTS	3
FIG. 1: PULSE GENERATOR TEST ARRANGEMENT.....	4
GENERAL OPERATING INSTRUCTIONS	5
FIG. 2: FRONT PANEL CONTROLS	7
FRONT PANEL CONTROLS	8
FIG. 3: BACK PANEL CONTROLS (EA, EW OPTION UNITS)	10
BACK PANEL CONTROLS.....	11
PERFORMANCE CHECK SHEET	12

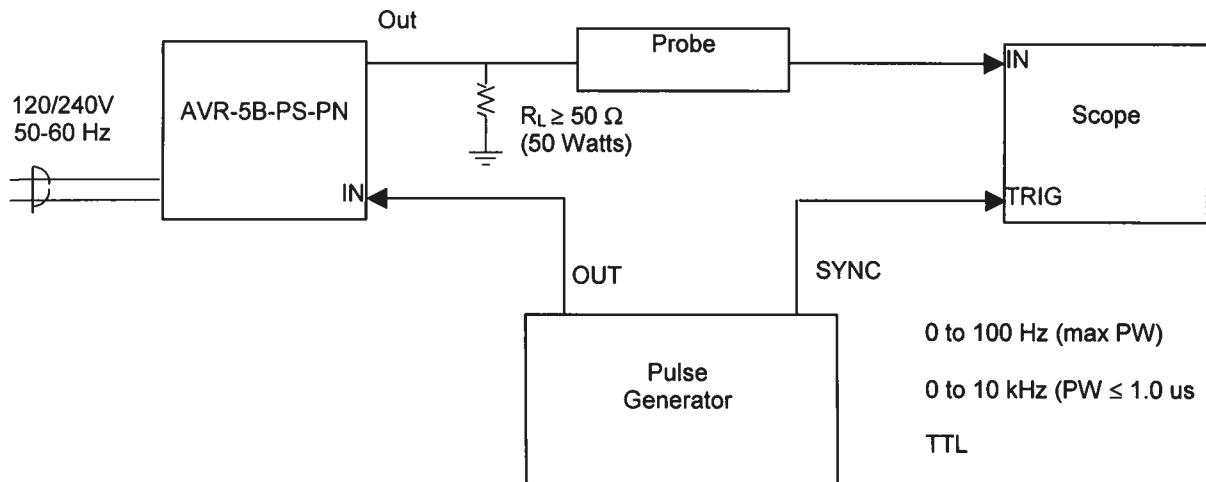
FIG. 1: PULSE GENERATOR TEST ARRANGEMENT

GENERAL OPERATING INSTRUCTIONS

- 1) The bandwidth capability of components and instruments used to display the pulse generator output signal (attenuators, cables, connectors, etc.) should exceed 100 MHz.
- 2) With the AB mode switch in the A position, the output pulse width is controlled by the 3 position PW range switch and the one turn PW control (10 turn control for units with the -PWT option). The minimum and maximum PW for each range and the corresponding maximum PRF are as follows. Note that the unit may fail if operated at duty cycles exceeding 1.0%.

	PW min	PW max
1)	0.1 us PRF max 10 kHz	1.0 us PRF max 10 kHz
2)	1.0 us PRF max 10 kHz	10 us PRF max KHz
3)	10 us PRF max 1 KHz	100 us PRF max 100 Hz

To voltage control the output pulse width within each range, set the rear panel switch in the EXT position and apply 0 to +1- Volts to BNC connector A. ($R_{IN} \geq 10K$).

- 3) With the AB mode switch in the B position, the output pulse width is equal to the input trigger pulse width.
- 4) The output pulse amplitude is controlled by means of the front panel ten-turn AMP control. To voltage control the output amplitude, set the rear panel switch in the EXT position and apply 0 to +10 Volts to BNC connector A ($R_{IN} \geq 10K$). (-EA option).
- 5) The output polarity is controlled by the two-position polarity switch. Note that to avoid stressing the output stage the amplitude should be turned down to zero before changing the position of the polarity switch.
- 6) The AVR-5B-PS features an output impedance of the order of several Ohms (rather than 50 Ohms). The following consequences of this feature should be noted:

- a) When used to switch some semiconductor devices (eg. bipolar and VMOS power transistors), the AVR unit will yield much faster switching times than those provided by 50-Ohm pulse generators.
- b) Ringing and overshoot will result when driving high impedance loads. To reduce the ringing, place a 50 Ohm resistor at the Pulser output. Also, keep the output cable length as short as possible.
- 8) **OVERLOAD INDICATOR.** AVR-5B units with a serial number higher than 5600 are protected by an automatic overload protective circuit, which controls the front panel overload light. If the unit is overloaded (by operating at an exceedingly high duty cycle or by operating into a short circuit), the protective circuit will turn the output of the instrument OFF and turn the indicator light ON. The light will stay ON (i.e. output OFF) for about 5 seconds after which the instrument will attempt to turn ON (i.e. light OFF) for about 1 second. If the overload condition persists, the instrument will turn OFF again (i.e. light ON) for another 5 seconds. If the overload condition has been removed, the instrument will turn on and resume normal operation. Overload conditions may be removed by:
 - 1) Reducing PRF (i.e. switch to a lower range)
 - 2) Reducing pulse width (i.e. switch to a lower range)
 - 3) Removing output load short circuit (if any)

Note that the overload light may illuminate when the prime power is first applied. The light will extinguish after a few seconds and the instrument will then function normally.

Note that the output stage will safely withstand a short-circuited load condition.

- 9) The unit can be converted from 120 to 230V 50-60 Hz operation by adjusting the voltage selector card in the rear panel fused voltage selector cable connector assembly.
- 10) For additional assistance:
 - Tel: (613) 226-5772
 - Fax: (613) 226-2802
 - E-mail: info@avtechpulse.com

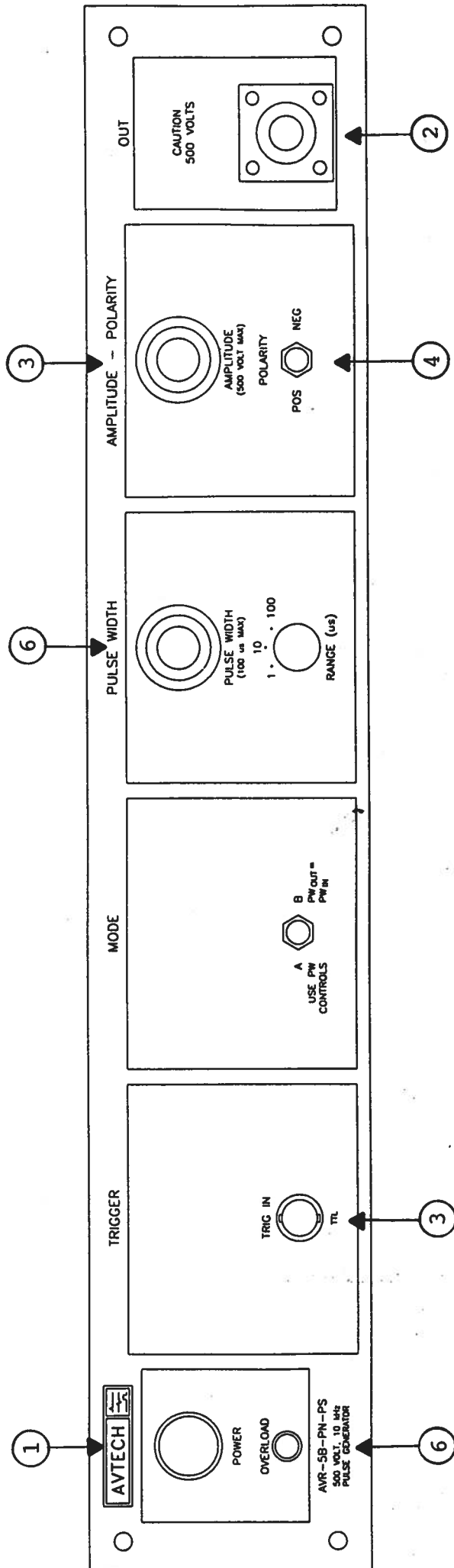

FIG. 2: FRONT PANEL CONTROLS

FRONT PANEL CONTROLS

- (1) ON-OFF Switch. Applies basic prime power to all stages.
- (2) OUT Connector. BNC connector provides output to the load ($R_L \geq 50 \text{ Ohm}$).
- (3) AMP Control. A ten-turn control, which varies the output pulse amplitude from 0 to 500 V.
- (4) POLARITY. The output polarity is controlled by the two-position polarity switch. Note that to avoid stressing the output stage the amplitude should be turned down to zero before changing the position of the polarity switch.
- (5) TRIG Input. The external trigger signal is applied at this input (TTL).
- (6) PW Control. A ten-turn control and 3-position range switch which varies the output pulse width from 0.1 μs to 100 μs . The minimum and maximum PW for each range and the corresponding maximum PRF are as follows. Note that the unit may fail if operated at duty cycles exceeding 0.5%.

	PW min	PW max
Range 1	0.1 μs PRF max 10 kHz	1.0 μs PRF max 10 kHz
Range 2	1.0 μs PRF max 10 kHz	10 μs PRF max 1 KHz
Range 3	10 μs PRF max 1 KHz	100 μs PRF max 100 Hz

- (7) AB MODE. When switch is in the A position output pulse width is controlled by PW controls (6) while if switch is in the B position, the output pulse width equals the input trigger pulse width.
- (8) OVERLOAD INDICATOR. AVR-5B units with a serial number higher than 5600 are protected by an automatic overload protective circuit which controls the front panel overload light. If the unit is overloaded (by operating at an exceedingly high duty cycle or by operating into a short circuit), the protective circuit will turn the output of the instrument OFF and turn the indicator light ON. The light will stay ON (i.e. output OFF) for about 5 seconds after which the instrument will attempt to turn ON (i.e. light OFF) for about 1 second. If the overload condition persists, the instrument will turn OFF again (i.e. light ON) for another 5 seconds.

If the overload condition has been removed, the instrument will turn on and resume normal operation. Overload conditions may be removed by:

- 1) Reducing PRF (i.e. switch to a lower range)
- 2) Reducing pulse width (i.e. switch to a lower range)
- 3) Removing output load short circuit (if any)

Note that the overload light may illuminate when the prime power is first applied. The light will extinguish after a few seconds and the instrument will then function normally.

Note that the output stage will safely withstand a short-circuited load condition.

FIG. 3: BACK PANEL CONTROLS (EA, EW OPTION UNITS)

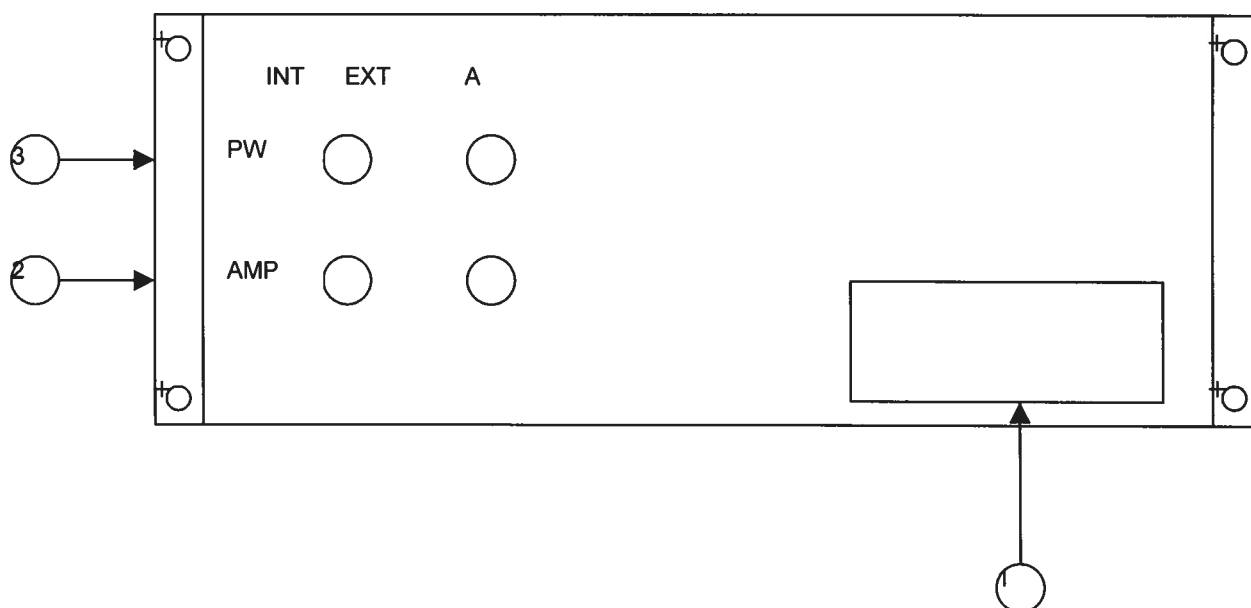

BACK PANEL CONTROLS

- (1) FUSED CONNECTOR, VOLTAGE SELECTOR. The detachable power cord is connected at this point. In addition, the removable cord is adjusted to select the desired input operating voltage. The unit also contains the main power fuse.

For AC line voltages of 110-120V, the power selector card should be installed so that the "120" marking is visible from the rear of the instrument.

For AC line voltages of 220-240V, the power selector card should be installed so that the "240" marking is visible from the rear of the instrument.

If it is not set for the proper voltage, remove the fuse and then grasp the card with a pair of pliers and remove it. Rotate horizontally through 180 degrees. Reinstall the card and the correct fuse.

In the 120V setting, a 1.0A slow blow fuse is required. In the 240V setting, a 0.5A slow blow fuse is required.

- (2) EA. To voltage control the output amplitude, set the switch in the EXT position and apply 0 to +10 Volts to BNC connector A ($R_{IN} \geq 10K$). (option).
- (3) EW. To voltage control the output pulse width, set the switch in the EXT position and apply 0 to +10 Volts to BNC connector A ($R_{IN} \geq 10K$). (option).