



AVTECH ELECTROSYSTEMS LTD.

NANOSECOND WAVEFORM ELECTRONICS
SINCE 1975

P.O. BOX 265
OGDENSBURG, NY
U.S.A. 13669-0265
TEL: (315) 472-5270
FAX: (613) 226-2802

TEL: 1-800-265-6681
FAX: 1-800-561-1970

e-mail: info@avtechpulse.com
<http://www.avtechpulse.com>

P.O. BOX 5120 STN. F
OTTAWA, ONTARIO
CANADA K2C 3H4
TEL: (613) 226-5772
FAX: (613) 226-2802

INSTRUCTIONS

MODEL AVR-7A-C-N-OP1B

0 TO -700 V, 10 kHz PULSE GENERATOR
WITH IEEE 488.2 AND RS-232 CONTROL

SERIAL NUMBER: _____

WARRANTY

Avtech Electrosystems Ltd. warrants products of its manufacture to be free from defects in material and workmanship under conditions of normal use. If, within one year after delivery to the original owner, and after prepaid return by the original owner, this Avtech product is found to be defective, Avtech shall at its option repair or replace said defective item. This warranty does not apply to units which have been disassembled, modified or subjected to conditions exceeding the applicable specifications or ratings. This warranty is the extent of the obligation assumed by Avtech with respect to this product and no other warranty or guarantee is either expressed or implied.

TECHNICAL SUPPORT

Phone: 613-226-5772 or 1-800-265-6681

Fax: 613-226-2802 or 1-800-561-1970

E-mail: info@avtechpulse.com

World Wide Web: <http://www.avtechpulse.com>

EC DECLARATION OF CONFORMITY

We

Avtech Electrosystems Ltd.
P.O. Box 5120, Stn. F
Ottawa, Ontario
Canada K2C 3H4

declare that the AVR-7A-C-N-OP1B pulse generator meets the intent of Directive 89/336/EEC for Electromagnetic Compatibility. Compliance pertains to the following specifications as listed in the official Journal of the European Communities:

EN 50081-1 Emission
EN 50082-1 Immunity



TABLE OF CONTENTS

WARRANTY	2
TECHNICAL SUPPORT	2
EC DECLARATION OF CONFORMITY	3
TABLE OF CONTENTS	4
INTRODUCTION	5
SPECIFICATIONS	6
INSTALLATION	7
VISUAL CHECK	7
PLUGGING IN THE INSTRUMENT	7
FRONT PANEL CONTROLS	8
REAR PANEL CONTROLS	10
GENERAL INFORMATION	11
BASIC PULSE CONTROL	11
TRIGGER MODES	13
PULSE WIDTH MODES	13
GATING MODES	13
OUTPUT IMPEDANCE	14
PREVENTING OUTPUT STAGE FAILURE	14
TOP COVER REMOVAL	14
ELECTROMAGNETIC INTERFERENCE	15
RACK MOUNTING	15
OPERATIONAL CHECK	16
PROGRAMMING YOUR PULSE GENERATOR	19
KEY PROGRAMMING COMMANDS	19
ALL PROGRAMMING COMMANDS	19
SYSTEM DESCRIPTION, SCHEMATICS, AND REPAIR PROCEDURE	21

INTRODUCTION

The AVR-7A-C-N-OP1B is a high performance, GPIB and RS232-equipped instrument capable of generating 0 to -700V at repetition rates up to 10 kHz into 50 Ω loads. The pulse delay is variable from 50 ns to 5 μ s, and the duty cycle may be as high as 0.5%. Rise and fall times are fixed at less than 50 ns. The AVR-7A-C-N-OP1B includes an internal trigger source, but it can also be triggered or gated by an external source. A front-panel pushbutton can also be used to trigger the instrument. The output pulse width can be set to follow an input trigger pulse width.

The AVR-7A-C-N-OP1B features front panel keyboard and adjust knob control of the output pulse parameters along with a four line by 40 character back-lit LCD display of the output amplitude, pulse width, pulse repetition frequency, and delay. The instrument includes memory to store up to four complete instrument setups. The operator may use the front panel or the computer interface to store a complete "snapshot" of all key instrument settings, and recall this setup at a later time.

The instrument is protected against overload conditions (such as short circuits) by an automatic control circuit. An internal power supply monitor removes the power to the output stage for five seconds if an average power overload exists. After that time, the unit operates normally for one second, and if the overload condition persists, the power is cut again. This cycle repeats until the overload is removed.

SPECIFICATIONS

Model:	AVR-7A-C-N-OP1B
Amplitude:	0 to -700 Volts, to $R_L \geq 50$ Ohms
Pulse width:	50 ns to 5 μ s
Rise time:	≤ 50 ns
Fall time:	≤ 50 ns
PRF:	1 Hz to 10 kHz
Max. duty cycle:	0.5%
Average power out (maximum):	50 W
Computer control:	GPIB and RS-232 interfaces included
Propagation delay:	≤ 100 ns (Ext trig in to pulse out)
Jitter:	± 100 ps (Ext trig in to pulse out)
Trigger required:	Internal Mode: +5 Volt, 50 ns or wider (TTL) External Mode: +5 Volt, $PW_{IN} = PW_{OUT}$ (TTL)
Sync delay:	Sync out to pulse out: Variable 0 to ± 100 μ s
Sync output:	+ 3 Volts, 200 ns, will drive 50 Ohm loads
Connectors:	Out: N type, Trig: BNC, Sync: BNC, Gate: BNC
Power, AC:	120/240 Volts (switchable) 50 - 60 Hz
Dimensions:	Mainframe: 100 mm x 430 mm x 375 mm (3.9" x 17" x 14.8")
Chassis material:	anodized aluminum, with blue plastic trim
Mounting:	Any
Temperature range:	+ 15° to + 40° C

INSTALLATION

VISUAL CHECK

After unpacking the instrument mainframe and the output module, examine to ensure that they have not been damaged in shipment. Visually inspect all connectors, knobs, liquid crystal displays (LCDs), and the handles. Confirm that a power cord and two instrumentation manuals (this manual and the "OP1B Interface Programming Manual") are with the instrument. If the instrument has been damaged, file a claim immediately with the company that transported the instrument.

PLUGGING IN THE INSTRUMENT

Examine the rear of the instrument. There will be a male power receptacle, a fuse holder and the edge of the power selector card visible. Confirm that the power selector is in the correct orientation - it should be marked either 120 or 240, indicating whether it expects 120V AC or 240V AC. If it is not set for the proper voltage, remove the fuse and then grasp the card with a pair of pliers and remove it. Rotate horizontally through 180 degrees. Reinstall the card and the correct fuse. In the 120V setting, a 1.0A slow blow fuse is required. In the 240V setting, a 1/2A slow blow fuse is required.

FRONT PANEL CONTROLS

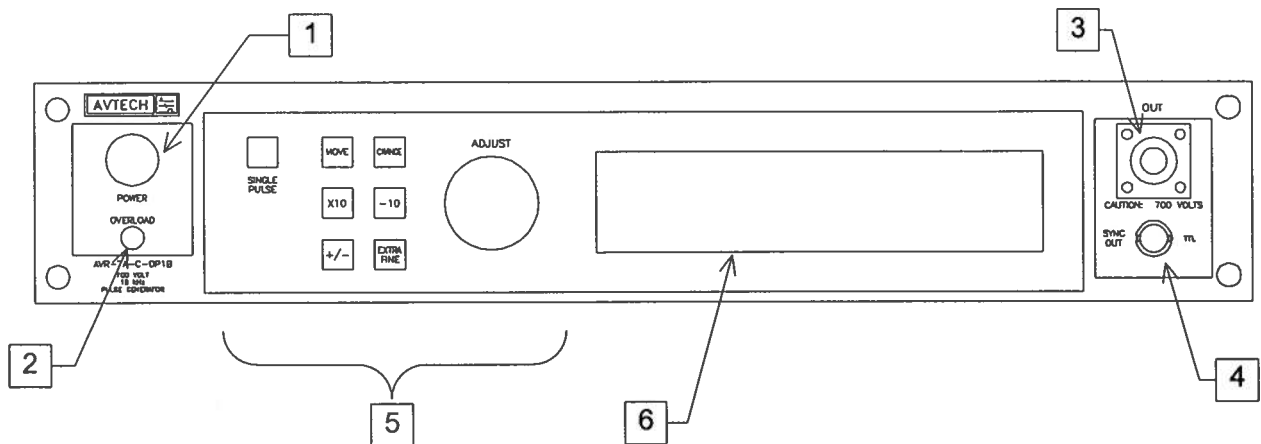

1. **POWER Switch**. The POWER push button switch applies AC prime power to the primaries of the transformer, turning the instrument on. The push button lamp (#382 type) is connected to the +15V DC supply.
2. **OVERLOAD**. The AVR-7A-C-N-OP1B is protected in its internal software against conflicting or dangerous settings. As an additional protective measure, an automatic overload circuit exists, which controls the front panel overload light. If the unit is overloaded (by operating at an exceedingly high duty cycle or by operating into a very low impedance), the protective circuit will turn the output of the instrument OFF and turn the indicator light ON. The light will stay ON (i.e. output OFF) for about 5 seconds after which the instrument will attempt to turn ON (i.e. light OFF) for about 1 second. If the overload condition persists, the instrument will turn OFF again (i.e. light ON) for another 5 seconds. If the overload condition has been removed, the instrument will turn on and resume normal operation.

This overload indicator is only likely to come on in two situations:

- Briefly at startup. This is not a cause for concern.
- When a low-impedance load ($R_L < 50\Omega$), or a short-circuit, is connected to the output. In this case, turn off the instrument and connect the proper load.

Note that the output stage will safely withstand a short circuited load condition.

3. **OUT CONNECTOR**. This N-type connector provides the output to a 50Ω (or higher) load.

- The arrow pointer should be pointing at the frequency menu item. If it is not, press the MOVE button until it is.
 - Press the CHANGE button. The frequency submenu will appear. Rotate the ADJUST knob until the frequency is set at 1 kHz.
 - The arrow pointer should be pointing at the "Internal" choice. If it is not, press MOVE until it is.
 - Press CHANGE to return to the main menu.
5. To set the delay to 1 μ s:
- Press the MOVE button until the arrow pointer is pointing at the delay menu item.
 - Press the CHANGE button. The delay submenu will appear. Rotate the ADJUST knob until the delay is set at 1 μ s.
 - The arrow pointer should be pointing at the "Normal" choice. If it is not, press MOVE until it is.
 - Press CHANGE to return to the main menu.
6. To set the pulse width to 1 μ s:
- Press the MOVE button until the arrow pointer is pointing at the pulse width menu item.
 - Press the CHANGE button. The pulse width submenu will appear. Rotate the ADJUST knob until the pulse width is set at 1 μ s.
 - The arrow pointer should be pointing at the "Normal" choice. If it is not, press MOVE until it is.
 - Press CHANGE to return to the main menu.
7. At this point, nothing should appear on the oscilloscope.
8. To enable the output:
- Press the MOVE button until the arrow pointer is pointing at the output menu item.
 - Press the CHANGE button. The output submenu will appear.

- Press MOVE until the arrow pointer is pointing at the “ON” choice.
 - Press CHANGE to return to the main menu.
9. To change the output amplitude:
- Press the MOVE button until the arrow pointer is pointing at the amplitude menu item.
 - Press the CHANGE button. The amplitude submenu will appear. Rotate the ADJUST knob until the amplitude is set at -200V.
 - Observe the oscilloscope. You should see 1 μ s wide, -200V pulses.
 - Rotate the ADJUST knob. The amplitude as seen on the oscilloscope should vary. Set it at -700V.
 - Press CHANGE to return to the main menu.
10. Repeat step 9, but set the amplitude to zero.
11. This completes the operational check.

PROGRAMMING YOUR PULSE GENERATOR

KEY PROGRAMMING COMMANDS

The "OP1B Interface Programming Manual" describes in detail how to connect the pulse generator to your computer, and the programming commands themselves. A large number of commands are available; however, normally you will only need a few of these. Here is a basic sample sequence of commands that might be sent to the instrument after power-up:

```
*rst                (resets the instrument)
trigger:source internal (selects internal triggering)
frequency 1000 Hz    (sets the frequency to 1000 Hz)
pulse:width 1 us     (sets the pulse width to 1 us)
pulse:delay 2 us     (sets the delay to 2 us)
volt -200            (sets the amplitude to -200 V)
output on            (turns on the output)
```

These commands will satisfy 90% of your programming needs.

ALL PROGRAMMING COMMANDS

For more advanced programmers, a complete list of the available commands is given below. These commands are described in detail in the "OP1B Interface Programming Manual". (Note: this manual also includes some commands that are not implemented in this instrument. They can be ignored.)

<u>Keyword</u>	<u>Parameter</u>	<u>Notes</u>
LOCAL		
OUTPut:		
:[STATe]	<boolean value>	
:PROTection		
:TRIPped?		[query only]
REMOTE		
[SOURce]:		
:FREQuency		
[:CW FIXed]	<numeric value>	
[SOURce]:		
:PULSe		
:PERiod	<numeric value>	
:WIDTh	<numeric value>	
:DCYClE	<numeric value>	
:HOLD	WIDTh DCYClE	
:DELay	<numeric value>	
:GATE		
:TYPE	ASYNc SYNc	
:LEVel	High Low	
[SOURce]:		

:VOLTage		
[:LEVel]		
[:IMMediate]		
[:AMPLitude]	<numeric value> EXTernal	
:PROTection		
:TRIPped?		[query only]
STATUS:		
:OPERation		
:[EVENT]?		[query only, always returns "0"]
:CONDition?		[query only, always returns "0"]
:ENABle	<numeric value>	[implemented but not useful]
:QUESTionable		
:[EVENT]?		[query only, always returns "0"]
:CONDition?		[query only, always returns "0"]
:ENABle	<numeric value>	[implemented but not useful]
SYSTEM:		
:COMMunicate		
:GPIB		
:ADDRes	<numeric value>	
:SERial		
:CONTRol		
:RTS	ON IBFull RFR	
:[RECeive]		
:BAUD	1200 2400 4800 9600	
:BITS	7 8	
:ECHO	<boolean value>	
:PARity		
:[TYPE]	EVEN ODD NONE	
:SBITS	1 2	
:ERRor		
:[NEXT]?		[query only]
:COUNT?		[query only]
:VERSion?		[query only]
TRIGger:		
:SOURce	INTernal EXTernal MANual HOLD IMMediate	
*CLS		[no query form]
*ESE	<numeric value>	
*ESR?		[query only]
*IDN?		[query only]
*OPC		
*SAV	0 1 2 3	[no query form]
*RCL	0 1 2 3	[no query form]
*RST		[no query form]
*SRE	<numeric value>	
*STB?		[query only]
*TST?		[query only]
*WAI		[no query form]

SYSTEM DESCRIPTION, SCHEMATICS, AND REPAIR PROCEDURE

CAUTION: It is strongly recommended that the unit be returned to Avtech for repairs and servicing. Potentials as high as 750 Volts DC are employed in the interior of this instrument so extreme caution must be exercised when attempting repairs. The following parts may be at high potential:

- Part No. SLR7P-A-N (and associated leads and capacitors).
- The two pairs of double-pins (surrounded by circular walls of white plastic insulator) on the 1C24-N125 module (and associated leads and capacitors).

The AVR-7A-C consists of the following basic modules:

1. AVR-7A-PG pulse generator module (either -P or -N)
2. 1C24-N125 high-voltage power supply module
3. SW75-24 +24V switching power supply
4. OP1B-PS main low-voltage power supply board
5. OP1B pulse generator timing and computer interface board
6. OL-471 overload module
7. EA amplitude control voltage level-shift module

The modules are interconnected as shown in the attached schematics.

In the event of an instrument malfunction, it is most likely that the 2.0 A slow blow fuse or the main power fuse on the rear panel has blown. Replace if necessary. If the unit still does not function, it is most likely that some of the output switching elements (IRFPG50) may have failed. The switching elements may be accessed by removing the top cover. The top cover is removed by removing the 4 Phillips screws on the top cover and then sliding the cover back and off.

NOTE: First set the amplitude to zero and then turn off the prime power. Allow the unit to sit for one minute before removing the top cover. Thoroughly ground the C4-C5 capacitor chain to discharge any remaining high voltage power supply potential.

The IRFPG50 may be removed from the mounting bracket and checked on a curve tracer and replaced if necessary. AVTECH Part No. SLR7P-A-N consists of the two transistors mounted on the bracket with insulating washers, 1 K resistors and output cable.

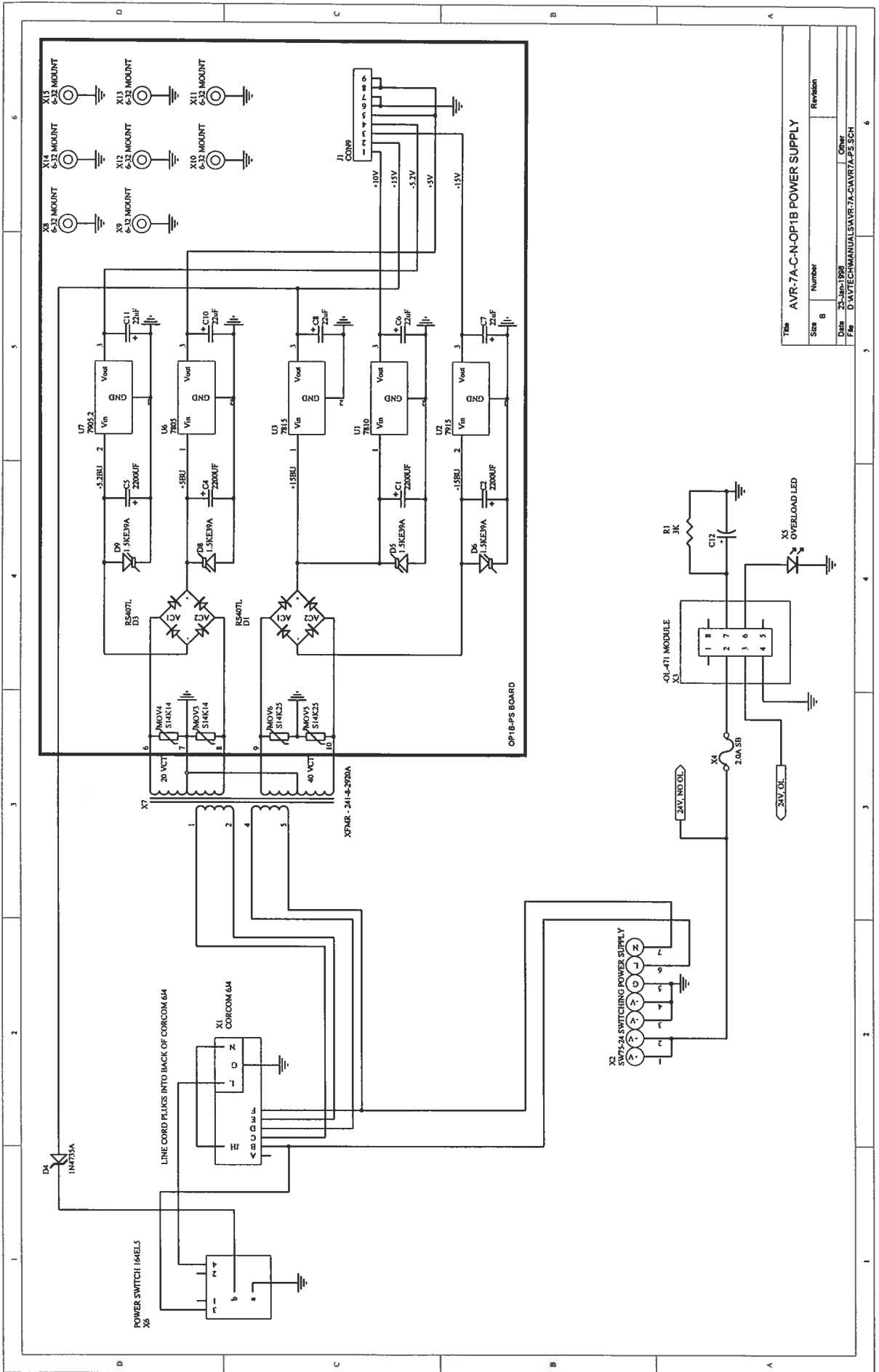

Title		Revision	
AVR-7A-C-N-OP1B POWER SUPPLY		Size	Number
Date	25-Jun-1998	Other	
File	D:\AVTECH\MANUALS\AVR7A-C\AVR7A-P.SCH		

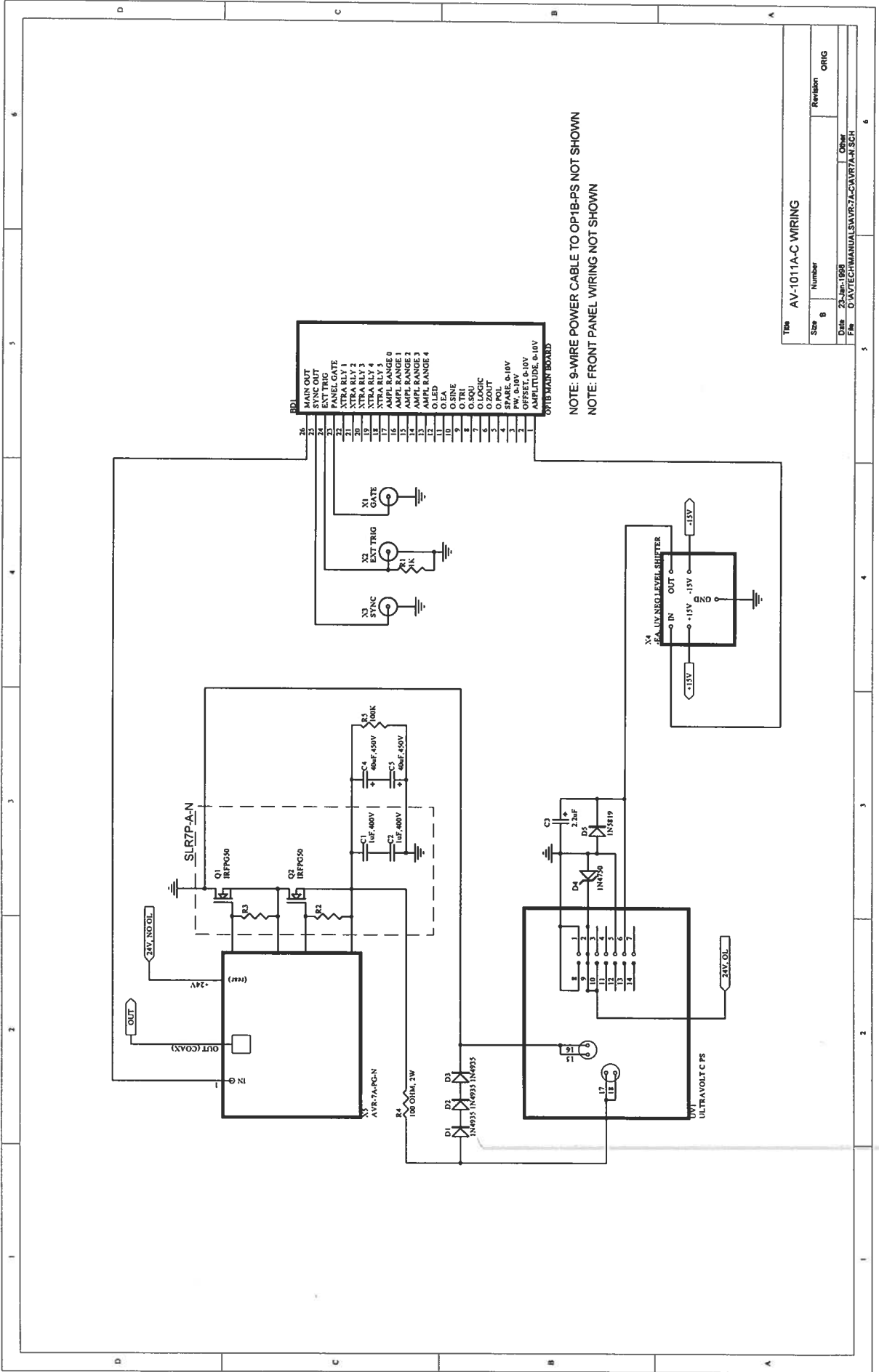

BDL	OPTIB MAIN BOARD
26	MAIN OUT
25	SYNC OUT
24	EXT TRIG
23	PANEL GATE
22	XTRA RLY 1
21	XTRA RLY 2
20	XTRA RLY 3
19	XTRA RLY 4
18	AMP RANGE 0
17	AMP RANGE 1
16	AMP RANGE 2
15	AMP RANGE 3
14	AMP RANGE 4
13	O P.A.
12	O SINE
11	O TRI
10	O SQU
9	O ZOUT
8	O POL
7	SPARE 0-10V
6	SPARE 0-10V
5	SPARE 0-10V
4	SPARE 0-10V
3	SPARE 0-10V
2	AMPLITUDE 0-10V
1	AMPLITUDE 0-10V

NOTE: 9-WIRE POWER CABLE TO OPTIB-PS NOT SHOWN
 NOTE: FRONT PANEL WIRING NOT SHOWN

Title		AV-1011A-C WIRING	
Size	Number	Revision	ORIG
Date	23-Jan-1968		
File	00VTECHMANUALS/AVR7ACAVR7A/WSCH	Other	

January 23/98

Michael did this set in Wad