

AVTECH ELECTROSYSTEMS LTD.

NANOSECOND WAVEFORM ELECTRONICS
ENGINEERING . MANUFACTURING

□ P.O. BOX 265
OGDENSBURG
NEW YORK
13669
(315) 472-5270

BOX 5120 STN. "F"
OTTAWA, ONTARIO
CANADA K2C 3H4
(613) 226-5772
TELEX 053-4591

INSTRUCTIONS

MODEL AVR-A-1-PS PULSE GENERATOR

S.N.:

WARRANTY

Avtech Electrosystems Ltd. warrants products of its manufacture to be free from defects in material and workmanship under conditions of normal use. If, within one year after delivery to the original owner, and after prepaid return by the original owner, this Avtech product is found to be defective, Avtech shall at its option repair or replace said defective item. This warranty does not apply to units which have been disassembled, modified or subjected to conditions exceeding the applicable specifications or ratings. This warranty is the extent of the obligation or liability assumed by Avtech with respect to this product and no other warranty or guarantee is either expressed or implied.

A.

TEST ARRANGEMENT

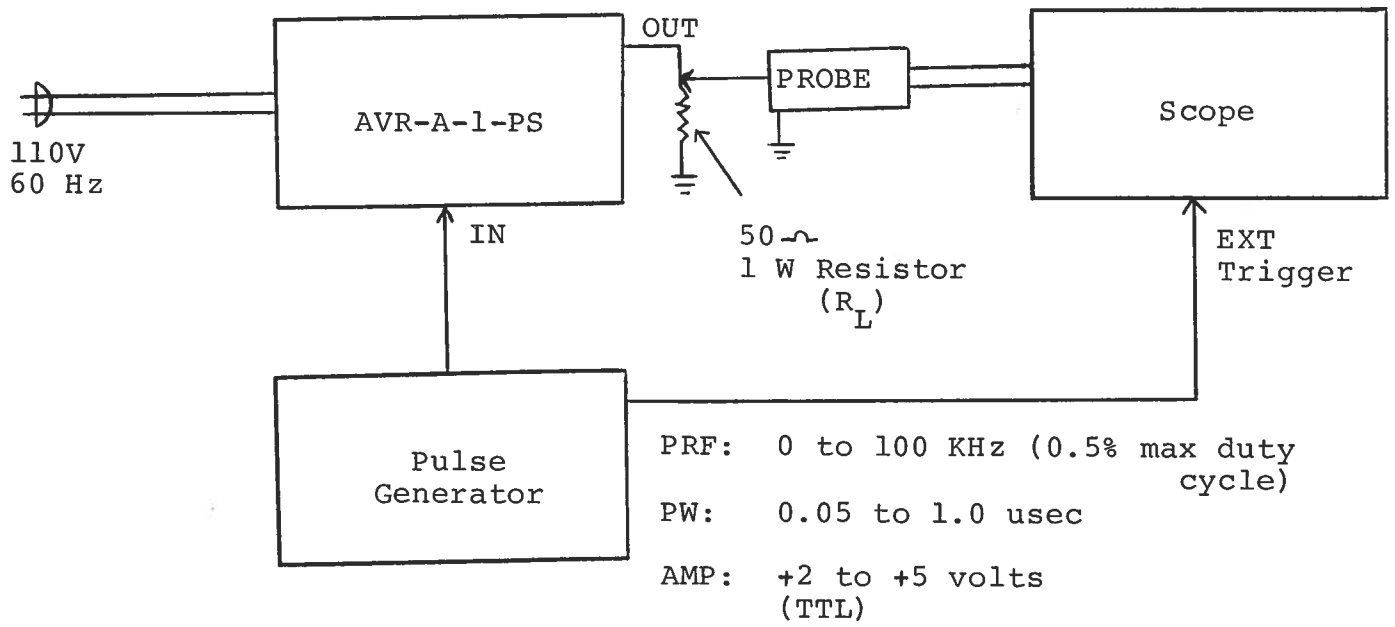

GENERAL OPERATING INSTRUCTIONS

- 1) The equipment should be connected in the general fashion shown above. Since the AVR unit provides an output pulse rise time as low as 10 nsec a fast oscilloscope (at least 50 MHz and preferably 200 MHz) should be used to display the waveform. Also, if a load of other than 50 ohm is employed, the length of coaxial cable between the AVR unit and the load should not exceed about 5 feet or the output waveform may be degraded by the resulting reflections.
- 2) The output PRF is equal to the input trigger pulse PRF.
- 3) The output pulse width is equal to the input trigger pulse width.
- 4) The output pulse amplitude is controlled by means of the front panel one turn AMP control.
- 5) To voltage control the output amplitude, remove the jumper wire between banana plugs A and B on the back panel and apply 0 to +10V to connector B ($R_{IN} \geq 10K$). (option).
- 6) Care should be taken to not operate with an output pulse width greater than 1 usec as prolonged operation in this mode may very well result in equipment failure. Also, the maximum PRF or duty cycle (0.5%) must not be exceeded for the same reason. Under simultaneous conditions of wide pulse width, high PRF and high load current, the bias voltage applied to the output power stage decreases and as a result the attainable output peak voltage decreases to less than 200 volts and the rear panel 0.5A SB fuse may blow. Under conditions of severe loading the output stage may be damaged.

Fig. 3

BACK PANEL CONTROLS

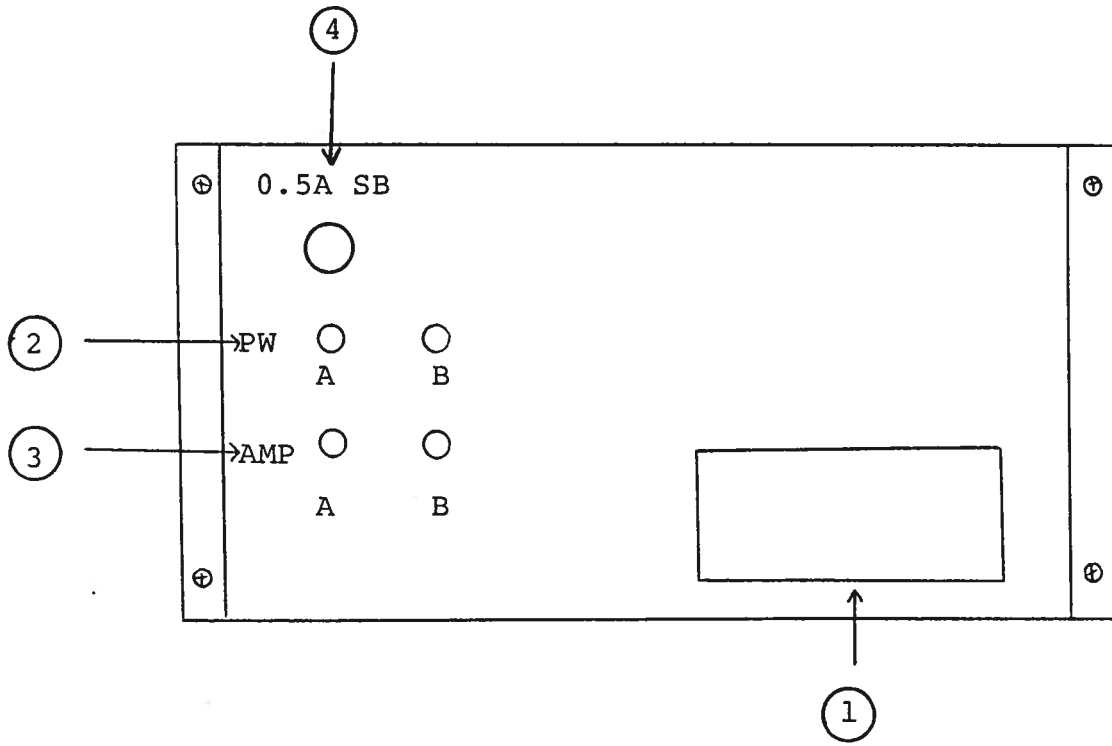

- (1) FUSED CONNECTOR, VOLTAGE SELECTOR. The detachable power cord is connected at this point. In addition, the removable cord is adjusted to select the desired input operating voltage. The unit also contains the main power fuse.
- (2) To voltage control the output pulse width, remove the jumper wire between banana plugs A and B and apply 0 to +10V to connector B ($R_{IN} \geq 10K$). (option).
- (3) To voltage control the output amplitude, remove the jumper wire between banana plugs A and B and apply 0 to +10V to connector B ($R_{IN} \geq 10K$). (option).
- (4) 0.5A SB. This fuse limits the DC prime power supplied to the output stage and will blow in the case of severe overloading. Do not exceed the duty cycle limits described in paragraph 6 of the general operating instructions.

C.

SYSTEM BLOCK DIAGRAM AND REPAIR PROCEDURE

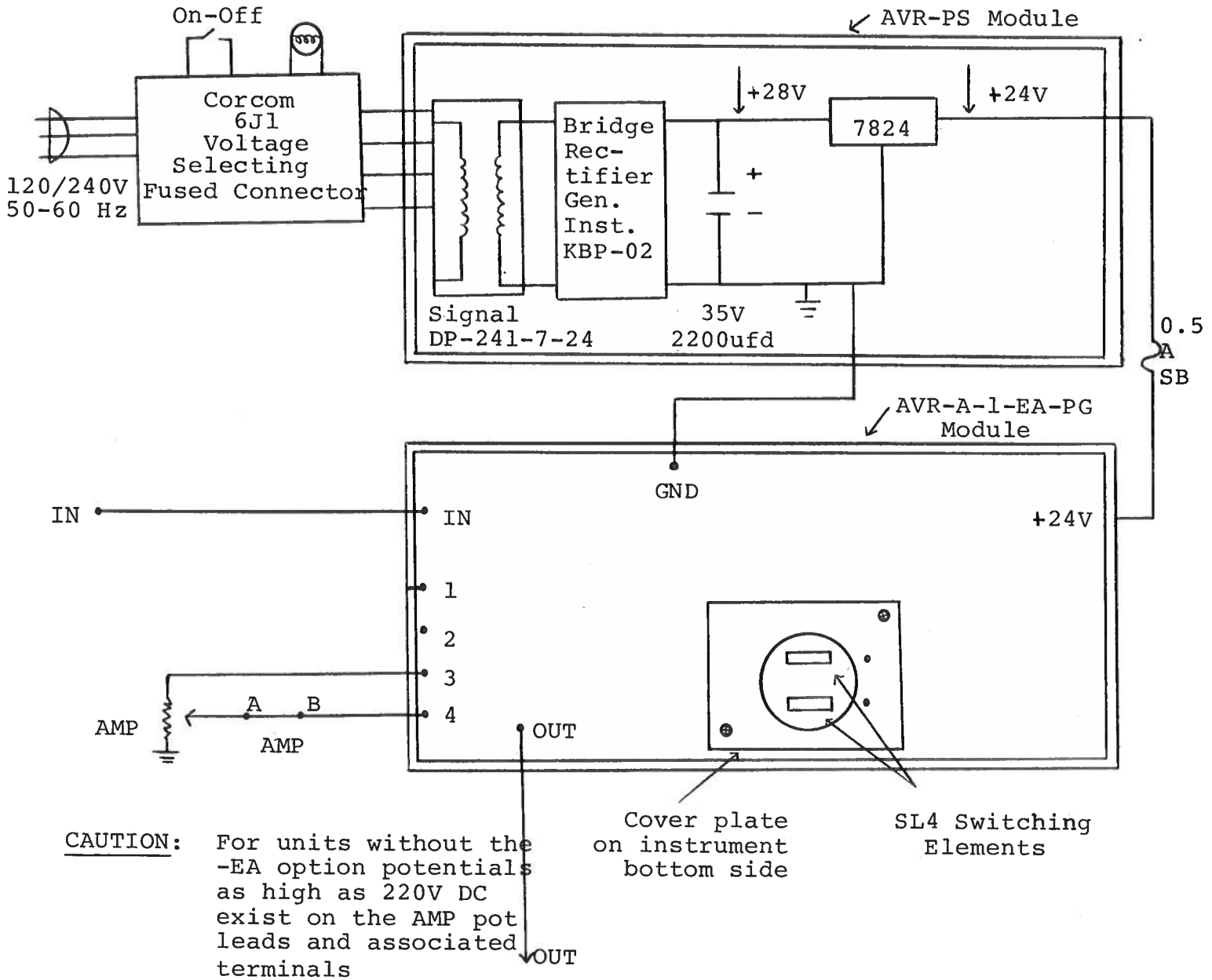

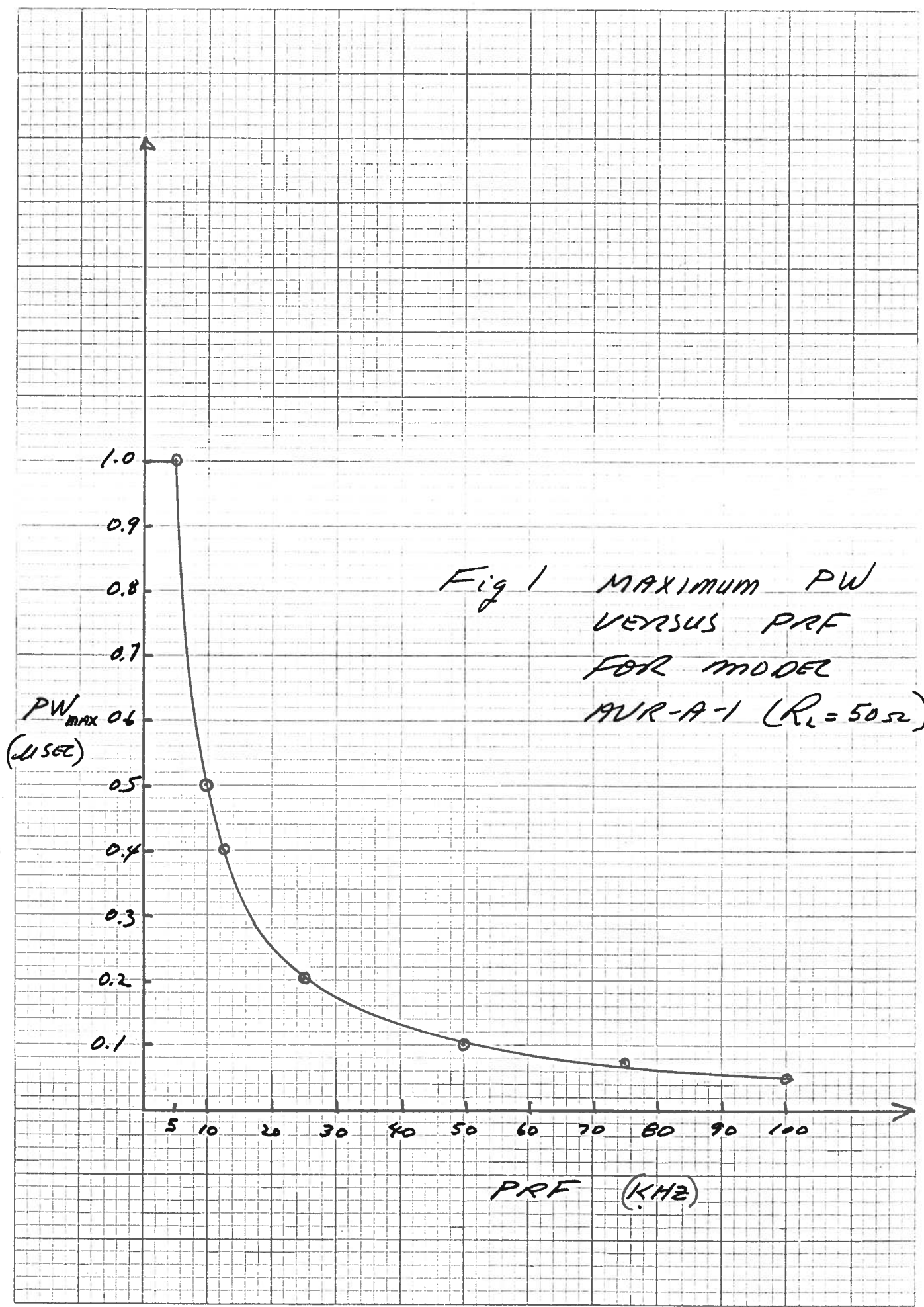

- 1) The AVR unit consists of three basic components or modules:
 - a) Metal chassis
 - b) AVR-PS module (Power Supply)
 - c) AVR-PG module (Pulse Generator)

The modules are interconnected as shown above.

- 2) If the unit malfunctions, first check the rear panel 0.5A SB fuse and then disconnect from the 60 Hz supply and the trigger source and remove the four Phillips screws on the back panel of the unit. With the screws removed, the top cover may be slid off.
- 3) Reconnect to the 60 Hz source and check the voltage on the line connecting the AVR-PS output to the +24 V pin of the AVR-PG module. A voltage of +24 volts should be recorded. If the voltage is substantially less than +24 volts, disconnect the 60 Hz source and disconnect the line from the +24 volt pin. Connect a 50 ohm 8 watt resistance to the output of the AVR-PS module. Reconnect to the 60 Hz source and measure the voltage across this resistor. A voltage of +24 volts should be indicated. If the voltage is substantially less than +24 volts the AVR-PS module is defective and should be either repaired or replaced. If the measured voltage is equal to +24 volts then the SL4 switching elements in the AVR-PG module have probably failed. The SL4 switching elements are easily replaced by removing the cover plate on the instrument bottom side and extracting the SL4 switching elements from their sockets using a pair of needle nose pliers. Before attempting this first insure that the prime power is off and also briefly ground the metal tabs on the SL4 elements to the chassis as the bypass capacitors may be charged to 225 volts. Replacement SL4 units must be ordered directly from Avtech. When reinstalling the SL4 units in their sockets, insure that the shortest of the three terminals is adjacent to the black dot on the AVR-PG chassis.

Schnoff

07.07.88

-EA

-EW