

# AVTECH ELECTROSYSTEMS LTD.

NANOSECOND WAVEFORM ELECTRONICS  
ENGINEERING - MANUFACTURING

□ P.O. BOX 265  
OGDENSBURG  
NEW YORK  
13669  
(315) 472-5270

✕ BOX 5120, STN. "F"  
OTTAWA, ONTARIO  
CANADA K2C 3H4  
TEL: (613) 226-5772  
FAX: (613) 226-2802  
TELEX: 053-4591

## INSTRUCTIONS

MODEL AVR-A-2-C PULSE GENERATOR

S.N. :

### WARRANTY

Avtech Electrosystems Ltd. warrants products of its manufacture to be free from defects in material and workmanship under conditions of normal use. If, within one year after delivery to the original owner, and after prepaid return by the original owner, this Avtech product is found to be defective, Avtech shall at its option repair or replace said defective item. This warranty does not apply to units which have been disassembled, modified or subjected to conditions exceeding the applicable specifications or ratings. This warranty is the extent of the obligation or liability assumed by Avtech with respect to this product and no other warranty or guarantee is either expressed or implied.

Fig. 1

PULSE GENERATOR TEST ARRANGEMENT

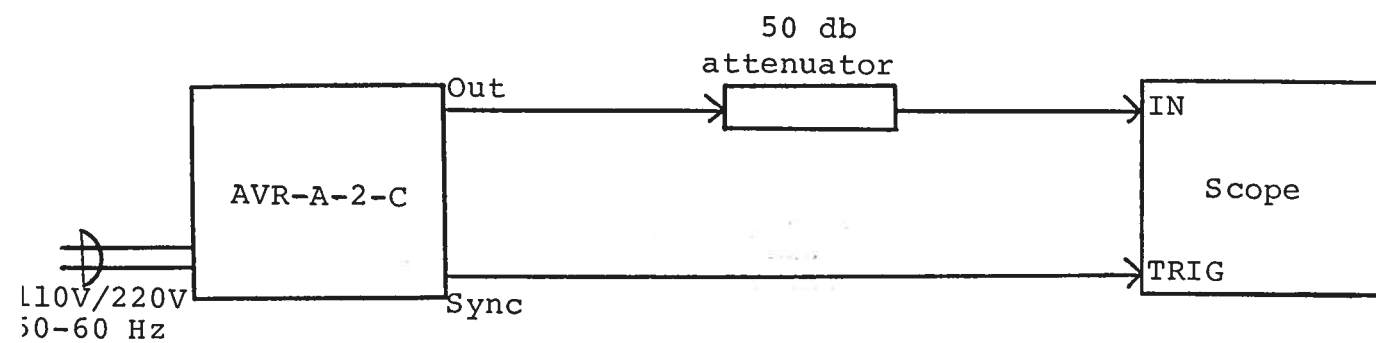

Notes:

- 1) The bandwidth capability of components and instruments used to display the pulse generator output signal (attenuators, cables, connectors, etc.) should exceed 100 MHz.
- 2) The use of 50 db attenuator at the scope vertical input channel will insure a peak input signal to the scope of less than one volt (necessary only if sampling scope used). If a high impedance real time scope is used, the pulse generator should be terminated using a shunt 50 ohm resistor.
- 3) The sync output channel provides a 20 nsec +0.5 volt pulse to fifty ohms.
- 4) For units with the dual output polarity option, the desired output polarity is selected by means of the rear panel POLARITY switch.
- 5) To obtain a stable output display the PW and PRF controls on the front panel should be set mid-range. The front panel TRIG toggle switch should be in the INT position. The DELAY controls and the scope triggering controls are then adjusted to obtain a stable output. The scope may then be used to set the desired PRF by rotating the PRF controls.
- 6) The output pulse width is controlled by means of the front panel one turn PW control.
- 7) The output pulse amplitude is controlled by means of the front panel one turn AMP control.
- 8) To voltage control the output pulse width, remove the jumper wire between banana plugs A and B on the back panel and apply 0 to +10V to connector B ( $R_{IN} \gg 10K$ ). (option).
- 9) To voltage control the output amplitude, remove the jumper wire between banana plugs A and B on the back panel and apply 0 to +10V to connector B ( $R_{IN} \gg 10K$ ). (option).
- 10) An external clock may be used to control the output PRF of the AVR unit by setting the front panel TRIG toggle switch in the EXT position and applying a 20 nsec (approx.) TTL level pulse to the TRIG BNC connector input. For operation in this mode, the scope time base must also be triggered by the external clock rather than from the SYNC output.

- 11) The AVR-A-2-C features an output impedance of the order of several ohms (rather than 50 ohms). The following consequences of this feature should be noted:
- a) When used to switch some semiconductor devices (eg. bipolar and VMOS power transistors), the AVR unit will yield much faster switching times than those provided by 50 ohm pulse generators.
  - b) The AVR unit will safely operate in to load impedances in the range of 50 ohms to an open circuit. However, the fall time may degrade for load impedances higher than fifty ohms.
  - c) The AVR unit may be effectively converted to a fifty ohm output impedance generator by placing a fifty ohm 1/2 watt carbon composition resistor in series with the output of the unit and the load. The maximum available load voltage will then decrease to 25 volts (from 50 volts).
  - d) The output switching elements may fail if the unit is inadvertently operated into a short circuit. The switching elements are easily replaced in the field following the procedure outlined in the REPAIR Section.
- 12) The maximum allowable output pulse width for each PRF range (1, 2 and 3, MAX and MIN) is given in the following table. The output amplitude will decrease and the unit may fail if the pulse width (i.e. 20% max duty cycle) conditions are exceeded. CAUTION: The AVR-A-2-C unit provides up to 10 watts average power to a 50 ohm load.
- 13) AVR-A-2-PW-C units with a serial number higher than 5600 are protected by an automatic overload protective circuit which controls the front panel overload light. If the unit is overloaded (by operating at an exceedingly high duty cycle or by operating into a short circuit), the protective circuit will turn the output of the instrument OFF and turn the indicator light ON. The light will stay ON (i.e. output OFF) for about 5 seconds after which the instrument will attempt to turn ON (i.e. light OFF) for about 1 second. If the overload condition persists, the instrument will turn OFF again (i.e. light ON) for another 5 seconds. If the overload condition has been removed, the instrument will turn on and resume normal operation. Overload conditions may be removed by:
- 1) Reducing PRF (i.e. switch to a lower range)
  - 2) Reducing pulse width (i.e. switch to a lower range)
  - 3) Removing output load short circuit (if any)

		MAX PW (usec)
Range 1		
PRF MAX	( $\approx$ 2 KHz)	200 nsec
PRF MIN	( $\approx$ 200 Hz)	200 nsec
Range 2		
PRF MAX	( $\approx$ 22 KHz)	200 nsec
PRF MIN	( $\approx$ 2 KHz)	200 nsec
Range 3		
PRF MAX	( $\approx$ 220 KHz)	200 nsec
PRF MIN	( $\approx$ 22 KHz)	200 nsec
Range 4		
PRF MAX	( $\approx$ 1.8 MHz)	180 nsec
PRF MIN	( $\approx$ 180 KHz)	200 nsec
Range 5		
PRF MAX	( $\approx$ 10 MHz)	20 nsec
PRF MIN	( $\approx$ 1.2 MHz)	180 nsec

- 14) The unit can be converted from 110 to 220V 50-60 Hz operation by adjusting the voltage selector card in the rear panel fused voltage selector cable connector assembly.

Fig. 2

FRONT PANEL CONTROLS

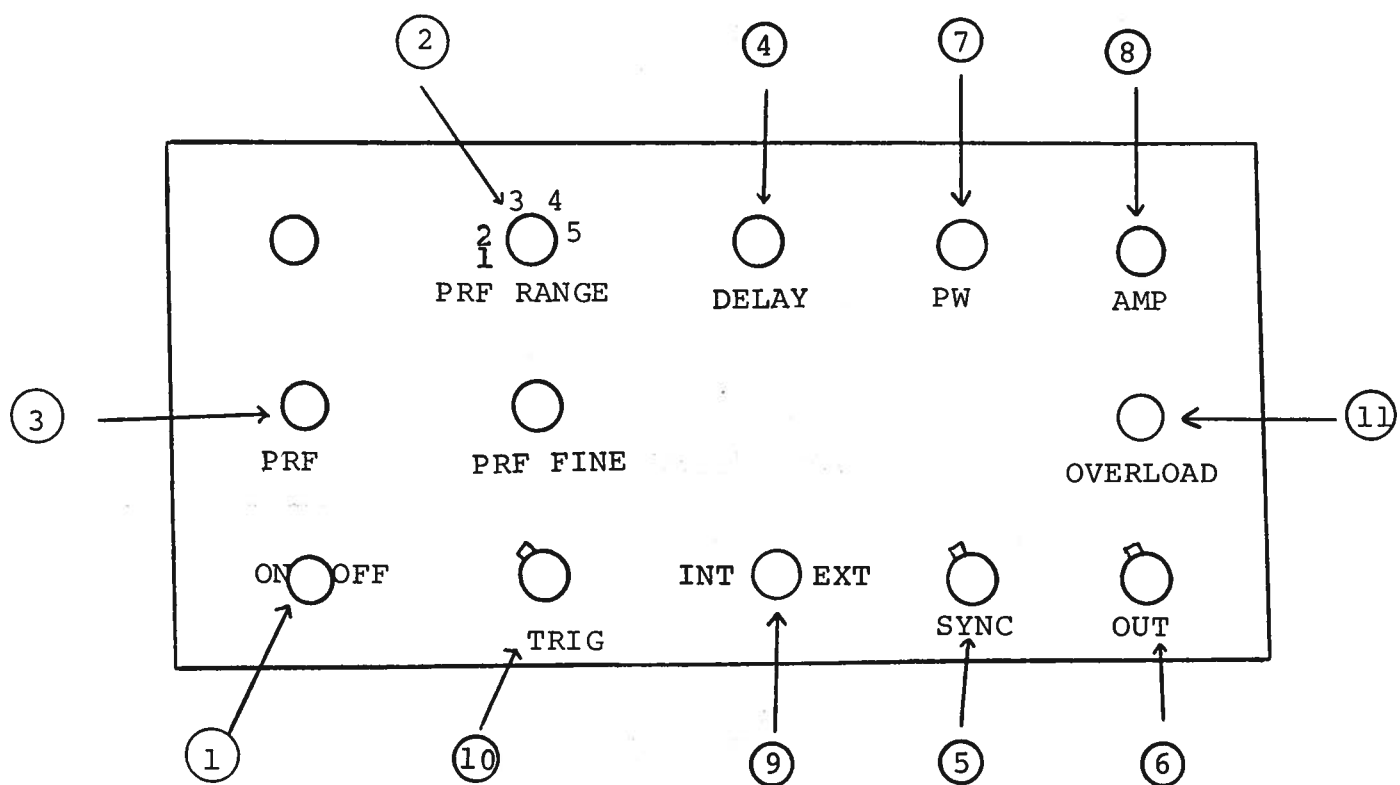

- (1) ON-OFF Switch. Applies basic prime power to all stages.
- (2) PRF Control. PRF RANGE and PRF controls determine output PRF as follows. The operating PRF should be set using a scope.

	PRF MIN	PRF MAX
Range 1	200 Hz	2 KHz
Range 2	2 KHz	22 KHz
Range 3	22 KHz	220 KHz
Range 4	180 KHz	1.8 MHz
Range 5	1.2 MHz	10 MHz

CAUTION: The output duty cycle must not exceed 0.5%. The AVR-A-2-C unit provides up to 10 volts to a 50 ohm load.

- (4) DELAY Control. Controls the relative delay between the reference output pulse provided at the SYNC output (5) and the main output (6). This delay is variable over the range of 0 to about 1.0 usec.
- (5) SYNC Output. This output precedes the main output (6) and is used to trigger the scope time base. The output is a +0.5 20 nsec (approx.) pulse capable of driving a fifty ohm load.
- (6) OUT Connector. BNC connector provides output to a fifty ohm load.
- (7) PW Control. A one turn control which varies the output pulse width.
- (8) AMP Control. A one turn control which varies the output pulse amplitude.
- (9) EXT-INT Control. With this toggle switch in the INT position, the PRF of the AVR unit is controlled via an internal clock which in turn is controlled by the PRF controls. With the toggle switch in the EXT position, the AVR unit requires a 20 nsec TTL level pulse applied at the TRIG input in order to trigger the output stages. In addition, in this mode, the scope time base must be triggered by the external trigger source.
- (10) TRIG Input. The external trigger signal is applied at this input when the EXT-INT toggle switch is in the EXT position.



(11) OVERLOAD. AVR-A-2-FW-C units with a serial number higher than 5600 are protected by an automatic overload protective circuit which controls the front panel overload light. If the unit is overloaded (by operating at an exceedingly high duty cycle or by operating into a short circuit), the protective circuit will turn the output of the instrument OFF and turn the indicator light ON. The light will stay ON (i.e. output OFF) for about 5 seconds after which the instrument will attempt to turn ON (i.e. light OFF) for about 1 second. If the overload condition persists, the instrument will turn OFF again (i.e. light ON) for another 5 seconds. If the overload condition has been removed, the instrument will turn on and resume normal operation. Overload conditions may be removed by:

- 1) Reducing PRF (i.e. switch to a lower range)
- 2) Reducing pulse width (i.e. switch to a lower range)
- 3) Removing output load short circuit (if any)

Fig. 3

BACK PANEL CONTROLS

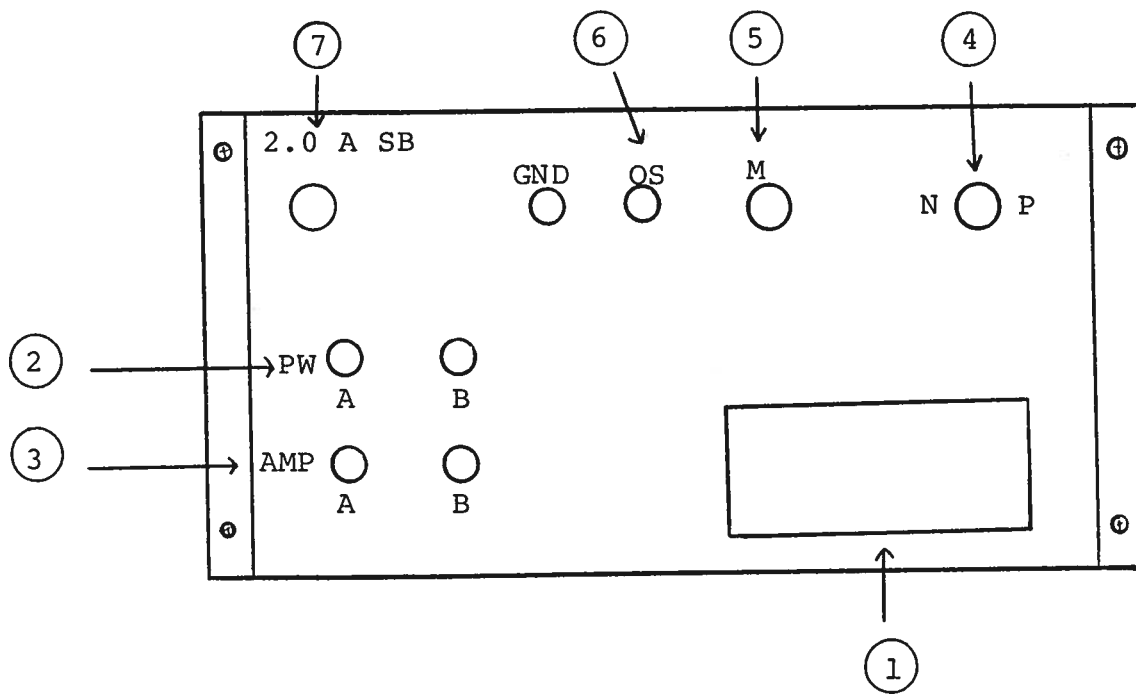

- (1) FUSED CONNECTOR, VOLTAGE SELECTOR. The detachable power cord is connected at this point. In addition, the removable cord is adjusted to select the desired input operating voltage. The unit also contains the main power fuse (0.5 A SB).
- (2) To voltage control the output pulse width, remove the jumper wire between banana plugs A and B and apply 0 to +10V to connector B ( $R_{IN} \geq 10K$ ). (option).
- (3) To voltage control the output amplitude, remove the jumper wire between banana plugs A and B and apply 0 to +10V to connector B ( $R_{IN} \geq 10K$ ). (option).
- (4) OUTPUT POLARITY CONTROL (option). With switch in (P) position, output is positive. With switch in (N) position, output pulse is negative.
- (5) MONITOR Output. The back monitor output provides an attenuated replica (20 db down) of the output less DC offset. The monitor output is designed to operate into a 50 ohm load. (option).
- (6) OFFSET Input. To DC offset the output pulse, connect a DC power supply set to the desired offset value to these terminals. The maximum allowable DC offset voltage is  $\pm 50$  volts.
- (7) 2.0A SB. This fuse limits the DC prime power supplied to the output stage and will blow in the case of severe overloading.

Fig. 4

SYSTEM BLOCK DIAGRAM

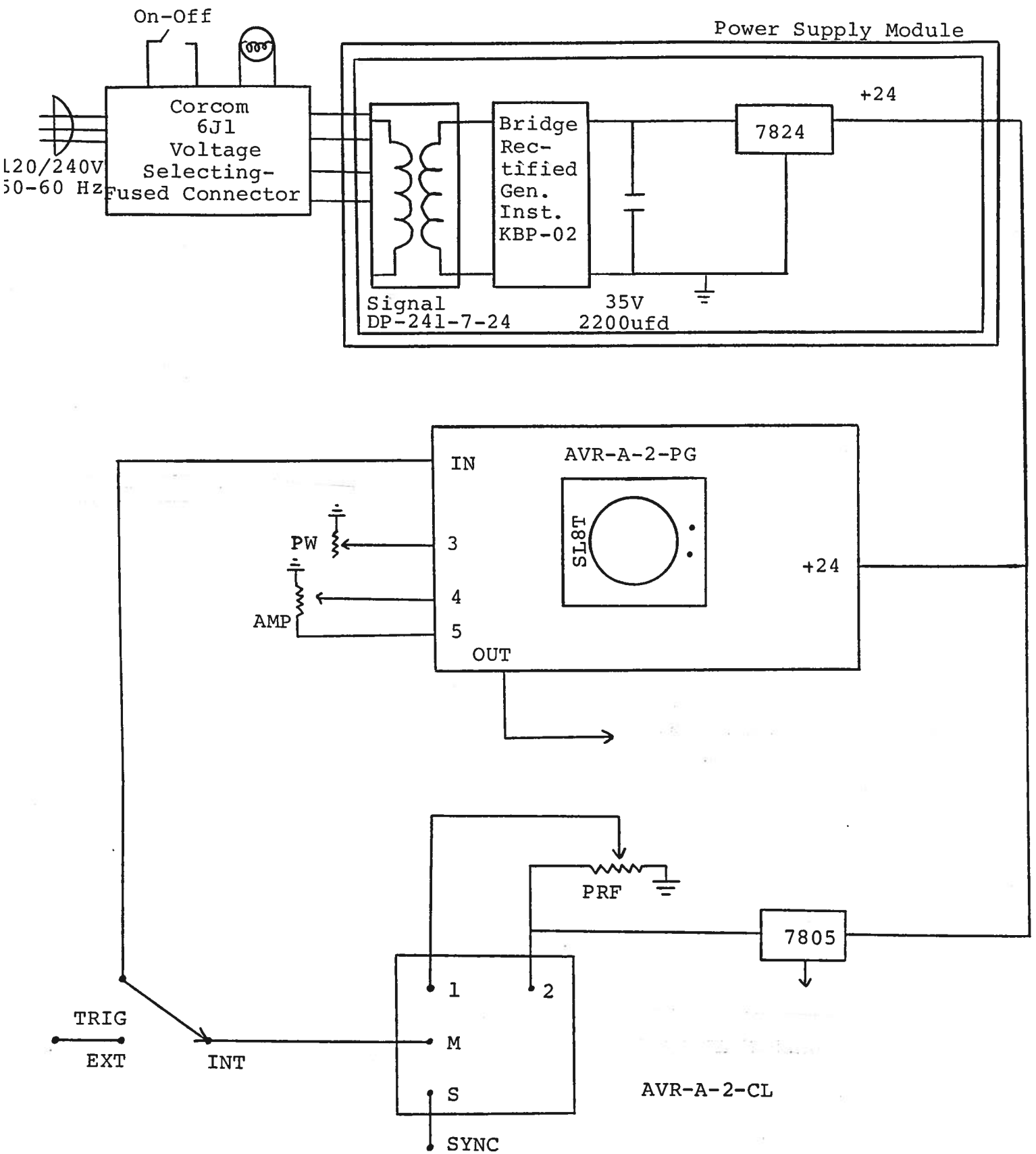

## SYSTEM DESCRIPTION AND REPAIR PROCEDURE

The AVR-A-2-C consists of the following basic modules:

- 1) AVR-A-2-PG pulse generator module
- 2) AVR-A-2-CL clock module
- 3) +24V power supply board

The modules are interconnected as shown in Fig. 4.

The clock module controls the output PRF and the relative delay between the main output and the SYNC outputs. The PG pulse generator modules generate the output pulse. In the event of an instrument malfunction, it is most likely that the rear panel 2.0 A SB fuse or some of the output switching elements (SL8T) may have failed due to an output short circuit condition or to a high duty cycle condition. The switching elements may be accessed by removing the cover plate on the bottom side of the chassis. NOTE: First turn off the prime power. CAUTION: Briefly ground the SL8T tabs to discharge the 60 volts power supply potential. The elements may be removed from their sockets by means of a needle nosed pliers after removing the four counter sunk 2-56 Phillips screws which attach the small aluminum heat sinks to the body of the chassis. The SL8T is a selected VMOS power transistor in a TO 220 package and may be checked on a curve tracer. If defective, replacement units should be ordered directly from Avtech. When replacing the SL8T switching elements, take care to insure that the short lead (of the three leads) is adjacent to the black dot on the chassis. The SL8T elements are electrically isolated from the small aluminum heat sinks but are bonded to the heat sinks using WAKEFIELD TYPE 155 HEAT SINK ADHESIVE. If the switching elements are not defective, then the four Phillips screws on the back panel should be removed. The top cover may then be slid off and the operation of the clock and power supply modules checked. The clock module is functioning properly if:

- a) 20 nsec outputs are observed at pins 2 and 3.
- b) The PRF of the outputs can be varied over the range of 0.1 KHz to 10 MHz using the PRF controls.
- c) The relative delay between the pin 2 and 3 outputs can be varied by at least 500 nsec by the DELAY control.

The sealed clock module must be returned to Avtech for repair or replacement if the above conditions are not observed. The power supply board generates +24V DC to power the other modules. If the voltage is less than +24V, turn off the prime power and unsolder the lead from the 7824 regulator chip on the power supply board. Solder a 100 ohm 5 watt resistor to the 7824 output to ground and turn on the prime power. A voltage of +24 volts should be read. If the voltage is less then the power supply board is defective and should be repaired or replaced.

Schroff 11.12.90 Edition B

-PN

-EW

-EA

-M

-OS

-PW