

AVTECH ELECTROSYSTEMS LTD.

**NANOSECOND WAVEFORM ELECTRONICS
ENGINEERING . MANUFACTURING**

□ P.O. BOX 265
OGDENSBURG
NEW YORK
13669
(315) 472-5270

BOX 5120 STN. "F"
OTTAWA, ONTARIO
CANADA K2C 3H4
(613) 226-5772
TELEX 053-4591

INSTRUCTIONS

MODEL AVR-B1-PS PULSE GENERATOR

S.N. :

WARRANTY

Avtech Electrosystems Ltd. warrants products of its manufacture to be free from defects in material and workmanship under conditions of normal use. If, within one year after delivery to the original owner, and after prepaid return by the original owner, this Avtech product is found to be defective, Avtech shall at its option repair or replace said defective item. This warranty does not apply to units which have been disassembled, modified or subjected to conditions exceeding the applicable specifications or ratings. This warranty is the extent of the obligation or liability assumed by Avtech with respect to this product and no other warranty or guarantee is either expressed or implied.

TEST ARRANGEMENT

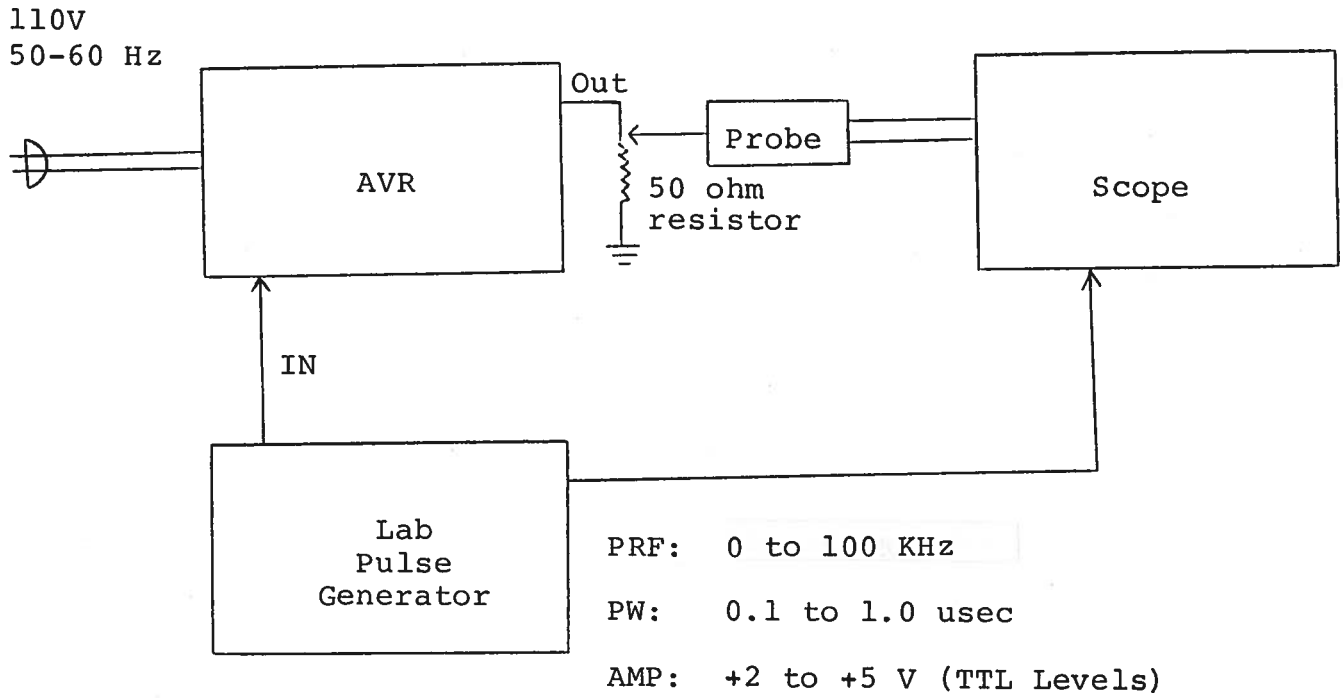

GENERAL OPERATING INSTRUCTIONS

- 1) The equipment should be connected in the general fashion shown above. A scope with a bandwidth of at least 200 MHz should be used to view output.
- 2) The output amplitude is controlled by means of the one turn potentiometer (AMP). To voltage control the output amplitude, remove the jumper wire between banana plugs A and B on the back panel and apply 0 to +10V to connector B ($R_{IN} \geq 10K$). (EA option).
- 3) The output pulse width is controlled by means of the one turn potentiometer (PW). To voltage control the output pulse width, remove the jumper wire between banana plugs A and B on the back panel and apply 0 to +10V to connector B ($R_{IN} \geq 10K$). (EW option).
- 4) The AVR is designed to operate into a load impedance of 50 ohm. The output switching elements may fail if the unit is inadvertently operated into a low impedance load. The switching elements are easily replaced in the field following the procedure outlined in the REPAIR Section.
- 5) **WARNING:** Model AVR may fail if triggered at a PRF greater than 50 KHz.
- 6) To DC offset the output pulse connect a DC power supply set to required DC offset value to the back panel terminals marked D.S. The maximum attainable DC offset voltage is ± 50 volts (OS option).
- 7) The output polarity is controlled by the rear panel two position polarity switch.

Fig. 2

SYSTEM BLOCK DIAGRAM

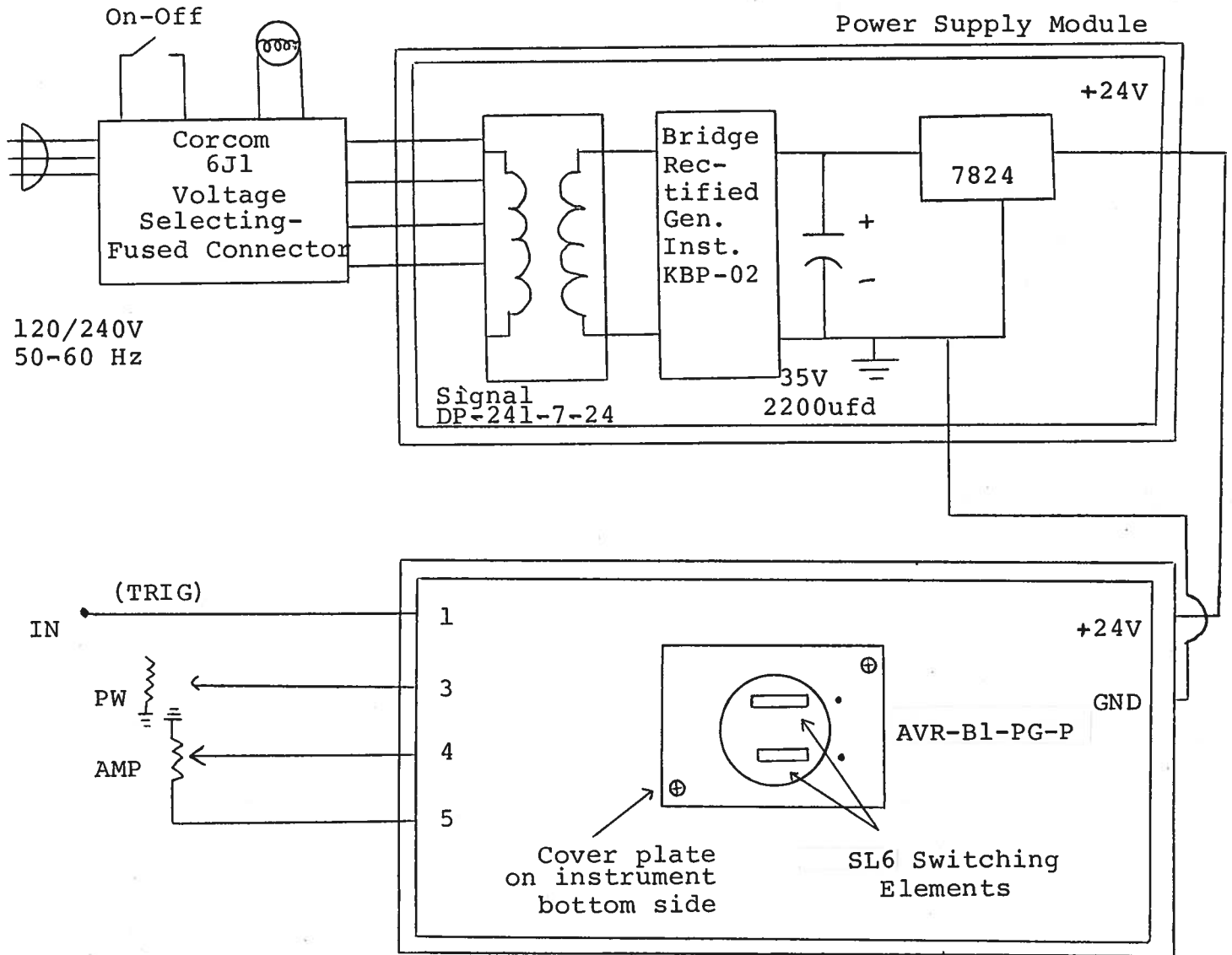

SYSTEM DESCRIPTION AND REPAIR PROCEDURE

The AVR consists of a pulse generator module (AVR-B1-PG) and a power supply board which supplies +24 volts (600 mA max) to the pulse generator module. In the event that the unit malfunctions, remove the instrument cover by removing the four Phillips screws on the back side of the unit. The top lid may then be slid off. Measure the voltage at the +24V pin of the PG module. If this voltage is substantially less than +24 volts, unsolder the line connecting the power supply and PG modules and connect 50 ohm 10 W load to the PS output. The voltage across this load should be about +24 V DC. If this voltage is substantially less than 24 volts the PS module is defective and should be repaired or replaced. If the voltage across the resistor is near 24 volts, then the SL6 switching elements in the AVR-PG module have probably failed. The SL6 switching elements are easily replaced by removing the cover plate on the instrument bottom side and extracting the SL6 switching elements from their sockets using a pair of needle nose pliers. Before attempting this first insure that the prime power is off and also briefly ground the metal tabs on the SL6 elements to the chassis as the bypass capacitors may be charged to 60 volts. Replacement SL6 units must be ordered directly from Avtech. When reinstalling the SL6 units in their sockets, insure that the shortest of the three terminals is adjacent to the black dot on the AVR-PG chassis.

Schroff 02.24.86

- EA
- EW
- OS
- PN