

AVTECH ELECTROSYSTEMS LTD.

NANOSECOND WAVEFORM ELECTRONICS
ENGINEERING - MANUFACTURING

□ P.O. BOX 265
OGDENSBURG
NEW YORK
13669
(315) 472-5270

BOX 5120, STN. "F"
OTTAWA, ONTARIO
CANADA K2C 3H4
TEL: (613) 226-5772
FAX: (613) 226-2802
TELEX: 053-4591

INSTRUCTIONS

MODEL AVR-B2-PN-C-MOTA2 PULSE GENERATOR

S.N.:

WARRANTY

Avtech Electrosystems Ltd. warrants products of its manufacture to be free from defects in material and workmanship under conditions of normal use. If, within one year after delivery to the original owner, and after prepaid return by the original owner, this Avtech product is found to be defective, Avtech shall at its option repair or replace said defective item. This warranty does not apply to units which have been disassembled, modified or subjected to conditions exceeding the applicable specifications or ratings. This warranty is the extent of the obligation or liability assumed by Avtech with respect to this product and no other warranty or guarantee is either expressed or implied.

Fig. 1

PULSE GENERATOR TEST ARRANGEMENT

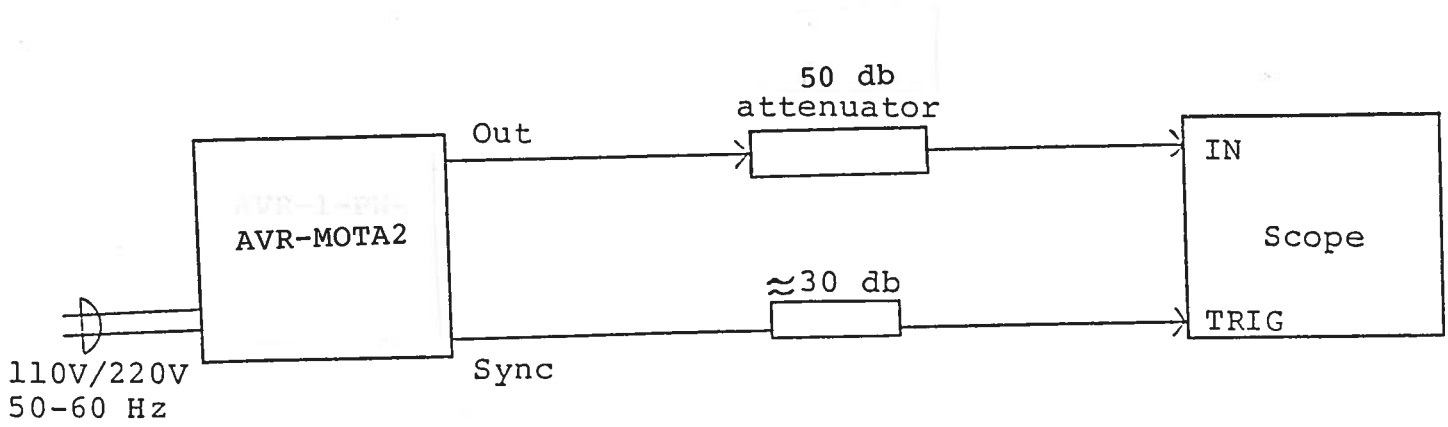

Notes:

- 1) The bandwidth capability of components and instruments used to display the pulse generator output signal (attenuators, cables, connectors, etc.) should exceed 100 MHz.
- 2) The use of 50 db attenuator at the scope vertical input channel will insure a peak input signal to the scope of less than one volt (necessary only if sampling scope used). If a high impedance real time scope is used, the pulse generator should be terminated using a shunt 50 ohm resistor.
- 3) The TRIG output channel provides TTL level signals. To avoid overdriving the TRIG input channel of some scopes, a 30 db attenuator should be placed at the input to the scope trigger channel. The TRIG output precedes the main output when the front panel LEAD-LAG switch is in the LEAD position. The TRIG output lags the main output when the switch is in the LAG position.
- 4) The desired output polarity is selected by means of the front panel POLARITY switch. To voltage control the output polarity, set the rear panel switch in the EXT position and apply 0 or +5V between terminal A and ground ($R_{IN} \geq 10K$) as follows:
 - 0 V: Output negative
 - +5V: Output positive
- 5) To obtain a stable output display the PW and PRF controls on the front panel should be set mid range. The front panel TRIG toggle switch should be in the INT position. The DELAY controls and the scope triggering controls are then adjusted to obtain a stable output. The scope may then be used to set the desired PRF by rotating the PRF controls. CAUTION: The unit may be damaged if the output duty cycle exceeds 2%. For example at the maximum pulse width of 1.0 usec, the PRF must not exceed 20 KHz while at the minimum pulse width of 0.2 usec, the max PRF must not exceed 100 KHz.
- 6) The output pulse widths for the positive and negative outputs are controlled by means of the front panel one turn PW control. NOTE, however, that when the unit is triggered externally, the output pulse width equals the input trigger pulse width.
- 7) The output pulse amplitudes for the positive and negative outputs are controlled by means of the front panel one turn AMP control.

- 8) To voltage control the output amplitude, set the rear panel switch in the EXT position and apply 0 to +10V between terminal A and ground ($R_{IN} \gg 10K$). (option).
- 9) The output PRF is controlled by the 3 position range switch and the one turn fine control.
- 10) To voltage control the output PRF within each range, set the rear panel switch in the EXT position and apply 0 to +10V between terminal A and ground ($R_{IN} \gg 10K$). (option).
- 11) An external clock may be used to control the output PRF of the AVR unit by setting the front panel TRIG toggle switch in the EXT position and applying a TTL level pulse to the TRIG BNC connector input. Note that for operation in this mode, the output pulse width is equal to the input trigger pulse width. For operation in this mode, the scope time base must also be triggered by the external clock rather than from the TRIG output.

Fig. 2

FRONT PANEL CONTROLS

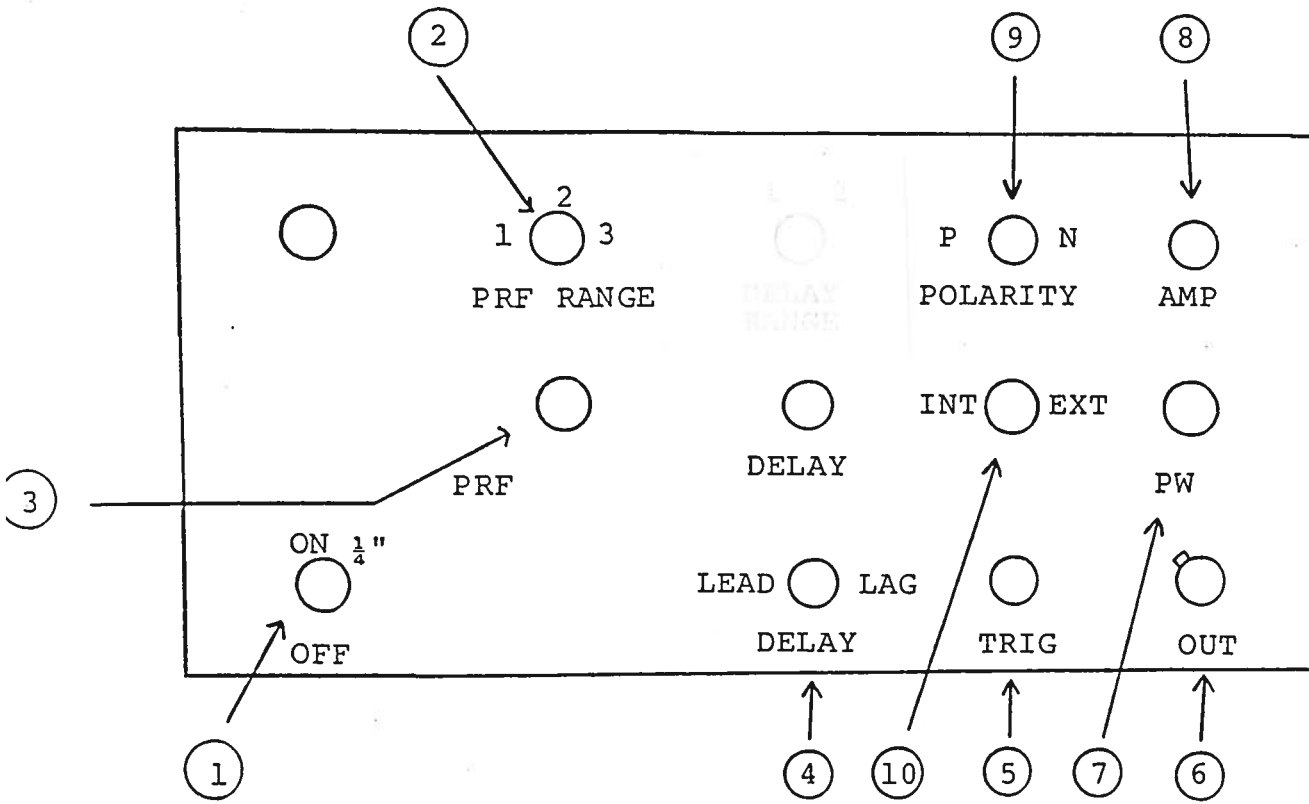

- (1) ON-OFF Switch. Applies basic prime power to all stages.
- (2) PRF Control. Varies PRF from 100 Hz to 100 KHz as follows:
- (3)
- | | | |
|---------|-------------------|-------|
| Range 1 | 100 Hz | 1 KHz |
| Range 2 | 1 KHz to 10 KHz | |
| Range 3 | 10 KHz to 100 KHz | |
- (4) DELAY Control. Controls the relative delay between the reference output pulse provided at the TRIG output (5) and the main output (6). This delay is variable over the range of 0 to about 1.0 usec. The TRIG output precedes the main output when the LEAD-LAG switch is in the LEAD position and lags when the switch is in the LAG position.
- (5) TRIG Output. This output is used to trigger the scope time base. The output is a TTL level 100 nsec (approx.) pulse capable of driving a fifty ohm load.
- (6) OUT Connector. BNC connector provides output to a fifty ohm load.
- (7) PW Control. A one turn control which varies the output pulse width from 0.2 usec to 1.0 usec.
- (8) AMP Control. A one turn control which varies the output pulse amplitude from 0 to 50 V to a fifty ohm load.
- (9) POLARITY Control. Controls polarity of output pulse.
- (10) EXT-INT Control. With this toggle switch in the INT position, the PRF of the AVR unit is controlled via an internal clock which in turn is controlled by the PRF controls. With the toggle switch in the EXT position, the AVR unit requires a TTL level pulse applied at the TRIG input in order to trigger the output stages. In this external mode the output pulse width is equal to the input trigger pulse width. In addition, in this mode, the scope time base must be triggered by the external trigger source.

Fig. 3

BACK PANEL CONTROLS

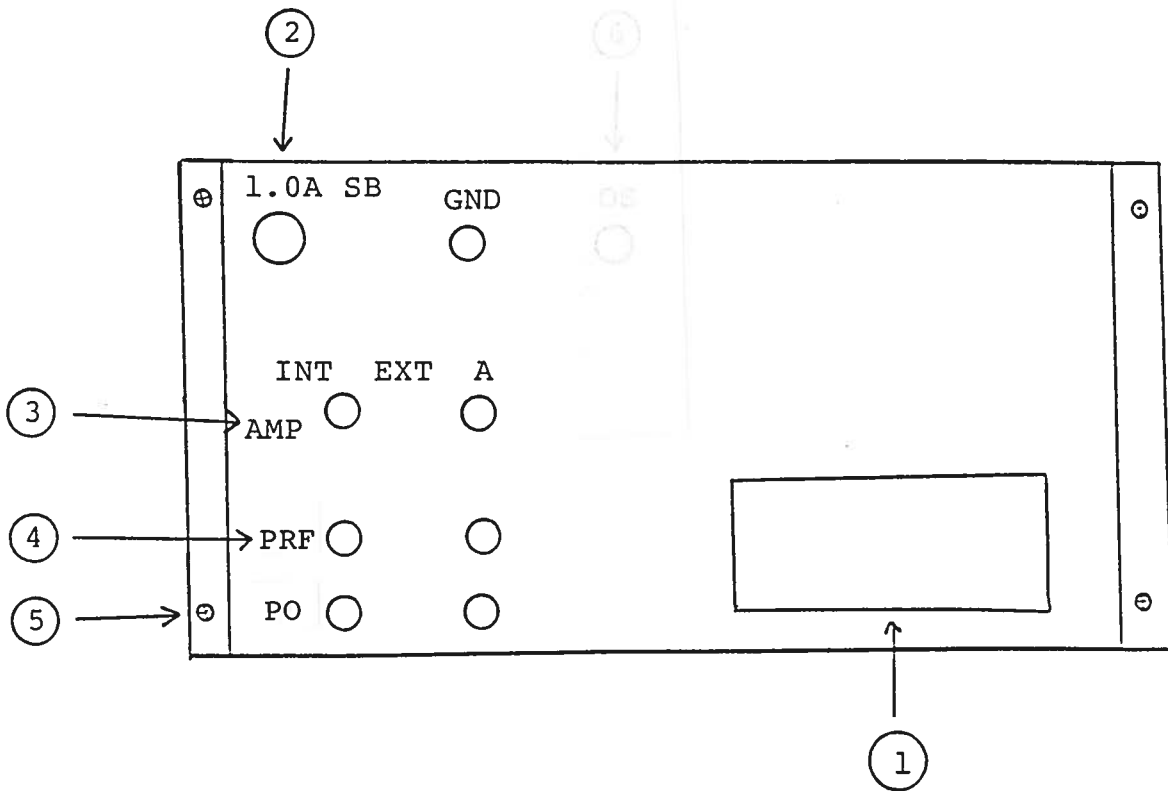

- (1) FUSED CONNECTOR, VOLTAGE SELECTOR. The detachable power cord is connected at this point. In addition, the removable cord is adjusted to select the desired input operating voltage. The unit also contains the main power fuse (0.25 amp).
- (2) 1.0A SB. Fuse which protects the output stage if the output duty cycle rating is exceeded.
- (3) AMP. To voltage control the output amplitude, set the switch in the EXT position and apply 0 to +10 volts between terminal A and ground ($R_{IN} \gg 10K$). (option).
- (4) PRF. To voltage control the output PRF within each range, set the switch in the EXT position and apply 0 to +10 volts between terminal A and ground ($R_{IN} \gg 10K$). (option).
- (5) POLARITY. To voltage control the output polarity, set the rear panel switch in the EXT position and apply 0 or +5V between terminal A and ground ($R_{IN} \gg 10K$) as follows:

0 V: Output negative
+5V: Output positive

Fig. 4

AVR-B2-PN-C-MOTA2

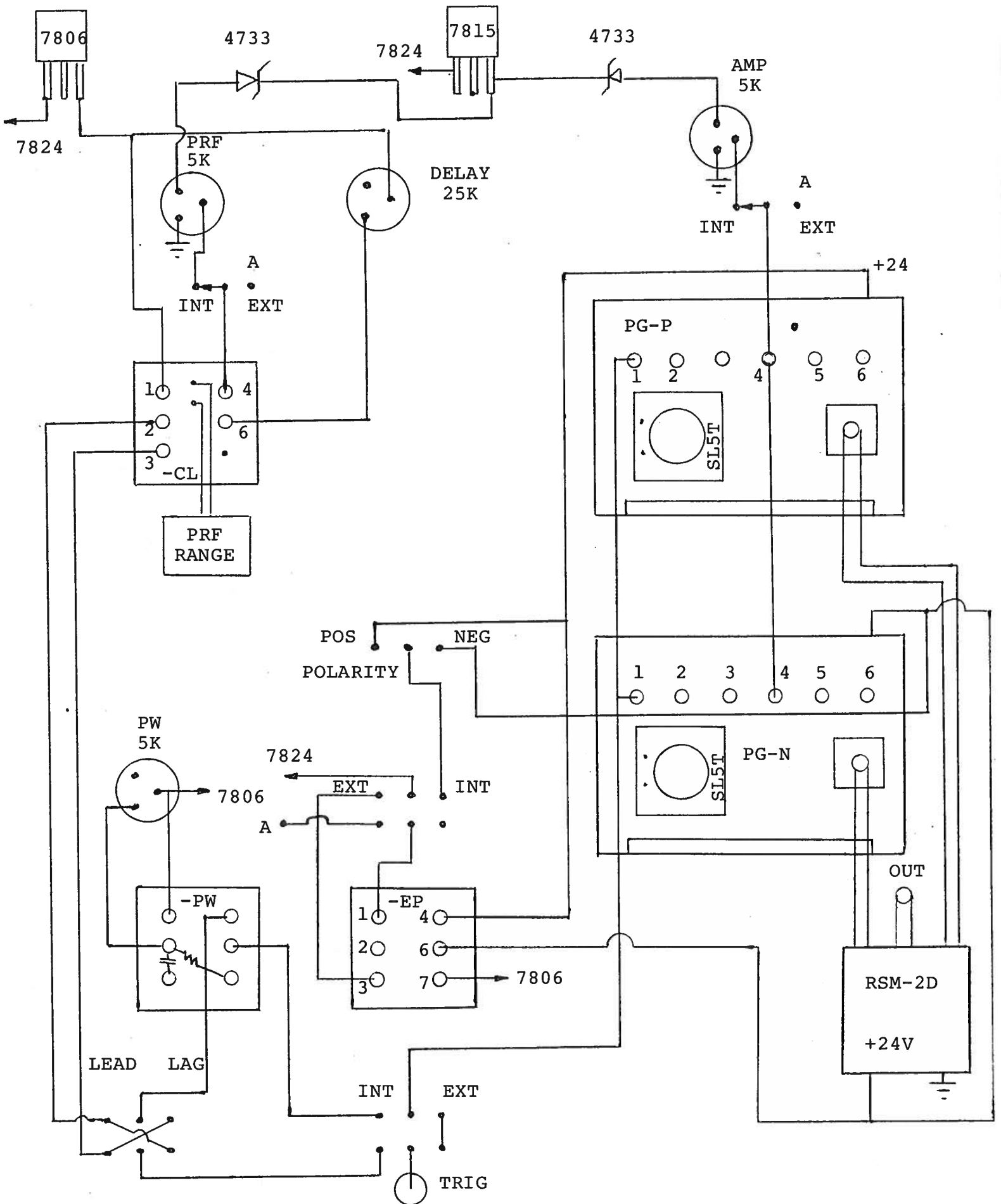

SYSTEM DESCRIPTION AND REPAIR PROCEDURE

The AVR-C-PN-MOTA2 consists of the following basic modules:

- 1) AVR-MOTA2 pulse generator modules (-P and -N)
- 2) AVR-CL clock module
- 3) +24V power supply board
- 4) AVR-PW pulse switch module

In the event of an instrument malfunction, it is most likely that the rear panel 1.0A SB fuse or some of the output switching elements (SL5T) may have failed due to an output short circuit condition or to a high duty cycle condition. The switching elements may be accessed by removing the cover plate on the bottom side of the instrument. NOTE: First turn off the prime power. The elements may be removed from their sockets by means of a needle nosed pliers. The SL5T is a selected VMOS power transistor in a TO 220 packages and may be checked on a curve tracer. If defective, replacement units should be ordered directly from Avtech. When replacing the SL5T switching elements, take care to insure that the short lead (of the three leads) is adjacent to the black dot on the chassis. If the switching elements are not defective, then the four Phillips screws on the back panel should be removed. The top cover may then be slid off and operation of the clock and power supply modules should be checked. The clock module is functioning properly if:

- a) 0.1 usec TTL level outputs are observed at pins 2 and 3.
- b) The PRF of the outputs can be varied over the range of 100 Hz to 100 KHz using the PRF controls.
- c) The relative delay between the pin 2 and 3 outputs can be varied by at least 1.0 usec by the DELAY controls.

The sealed clock module must be returned to Avtech for repair or replacement if the above conditions are not observed. The power supply board generates +24V DC to power the other modules. If the voltage is less than +24V, turn off the prime power and unsolder the lead from the 7824 regulator chip on the power supply board. Solder a 100 ohm 5 watt resistor to the 7824 output to ground and turn on the prime power. A voltage of +24 volts should be read. If the voltage is less then the power supply board is defective and should be repaired or replaced.

Schroff

01.05.90

Edition A

-EA