



AVTECH ELECTROSYSTEMS LTD.
NANOSECOND WAVEFORM ELECTRONICS

P.O. BOX 265
OGDENSBURG, NY
U.S.A. 13669-0265
TEL: (315) 472-5270
FAX: (613) 226-2802

BOX 5120 STN. F
OTTAWA, ONTARIO
CANADA K2C 3H4
TEL: (613) 226-5772
FAX: (613) 226-2802

INSTRUCTIONS

MODEL AVR-B3 PULSE GENERATOR

S.N.:

WARRANTY

Avtech Electrosystems Ltd. warrants products of its manufacture to be free from defects in material and workmanship under conditions of normal use. If, within one year after delivery to the original owner, and after prepaid return by the original owner, this Avtech product is found to be defective, Avtech shall at its option repair or replace said defective item. This warranty does not apply to units which have been disassembled, modified or subjected to conditions exceeding the applicable specifications or ratings. This warranty is the extent of the obligation or liability assumed by Avtech with respect to this product and no other warranty or guarantee is either expressed or implied.

A.

TEST ARRANGEMENT

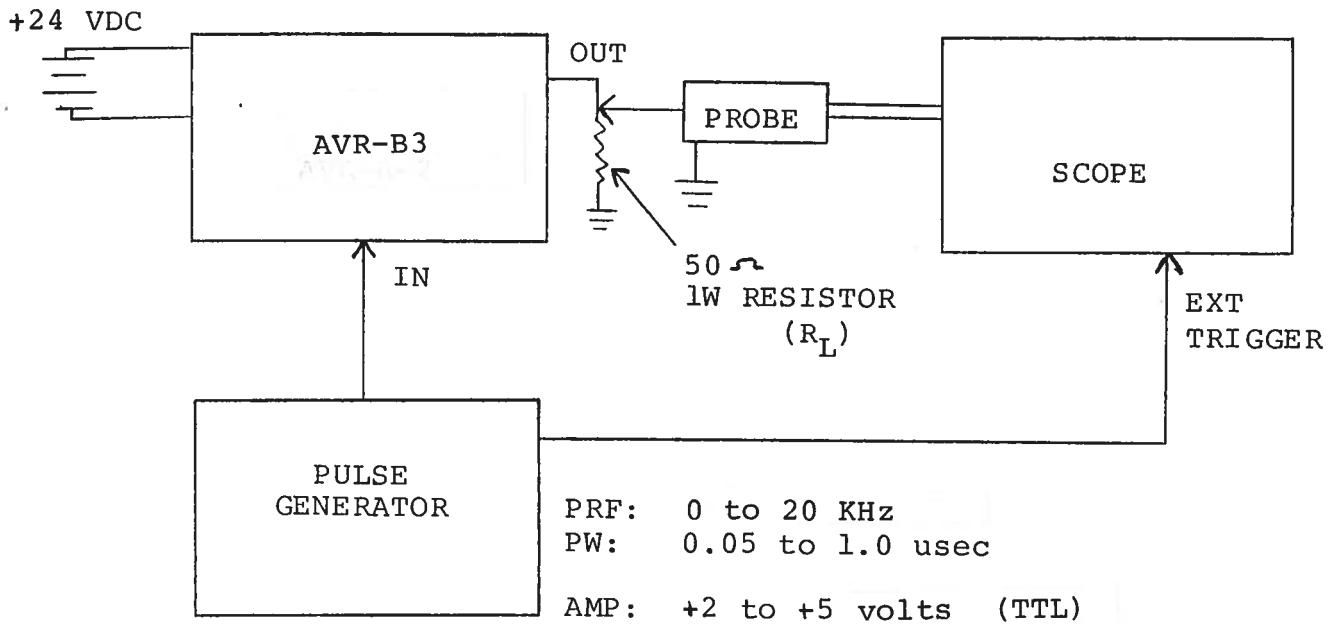

B.

GENERAL OPERATING INSTRUCTIONS

- 1) The equipment should be connected in the general fashion shown above. Since the AVR unit provides an output pulse rise time as low as 3 nsec a fast oscilloscope (at least 200 MHz) should be used to display the waveform.
- 2) The magnitude of the output pulse is controlled by the front panel one turn pot (AMP). Maximum clockwise rotation of the pot provides the maximum output. For units with the EA option, the output amplitude is controlled by 0 to +10 volt applied to the AMP solder terminal ($R_{IN} \gg 10K$).
- 3) The output pulse width is controlled by the one turn PW pot. For units with the EW option, the output pulse width is controlled by 0 to +10 volt applied to the PW solder terminal ($R_{IN} \gg 10K$).
- 4) In the event of severe overloading, the output switching elements (Avtech Part No. SL5) may fail. The SL5 units are readily replaced by removing the four screws which affix the small cover plate to the bottom of the AVR chassis. The four 2-56 counter sink screws are then removed. The SL5 units may then be extracted using needle nosed pliers. When replacing the SL5 units take care to ensure that the short lead is placed adjacent to the black dot on the AVR chassis.

PULSE GENERATOR
PERFORMANCE CHECK

Model: *APR-B3-EN-CA-P*

S.N.: *5065*

Date: *JUNE 9 89*

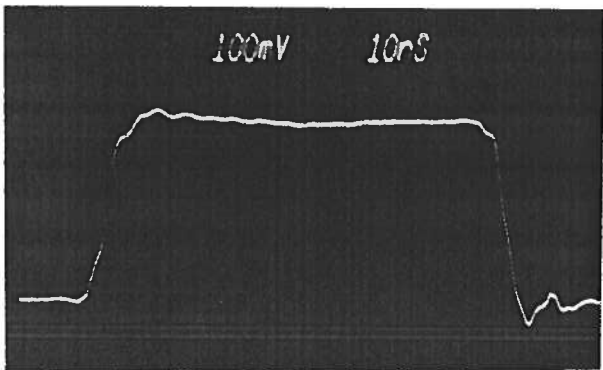

50 db ATTEN

∴ ≈ 32 VOLTS/Div

PRF = 20 KHz

a) Output signal amplitude:

0 TO +100 VOLTS

b) Pulse width:

20 TO 200 NS

c) Rise time:

≤ 5 NS

d) Fall time:

≤ 5 NS

e) PRF:

0 TO 20 KHz

f) Jitter, stability:

OK

g) Prime power:

+24 ± 1.0 VOLTS

300 mA (max)

[Signature]