

*App. total*

# AVTECH ELECTROSYSTEMS LTD.

NANOSECOND WAVEFORM ELECTRONICS  
ENGINEERING . MANUFACTURING

□ P.O. BOX 265  
OGDENSBURG  
NEW YORK  
13869  
(315) 472-5270

BOX 5120 STN. "F"  
OTTAWA, ONTARIO  
CANADA K2C 3H4  
(613) 226-5772  
TELEX 053-4591

## INSTRUCTIONS

MODEL AVR-B3-W PULSE GENERATOR

S.N.:

## WARRANTY

Avtech Electrosystems Ltd. warrants products of its manufacture to be free from defects in material and workmanship under conditions of normal use. If, within one year after delivery to the original owner, and after prepaid return by the original owner, this Avtech product is found to be defective, Avtech shall at its option repair or replace said defective item. This warranty does not apply to units which have been disassembled, modified or subjected to conditions exceeding the applicable specifications or ratings. This warranty is the extent of the obligation or liability assumed by Avtech with respect to this product and no other warranty or guarantee is either expressed or implied.

A.

TEST ARRANGEMENT

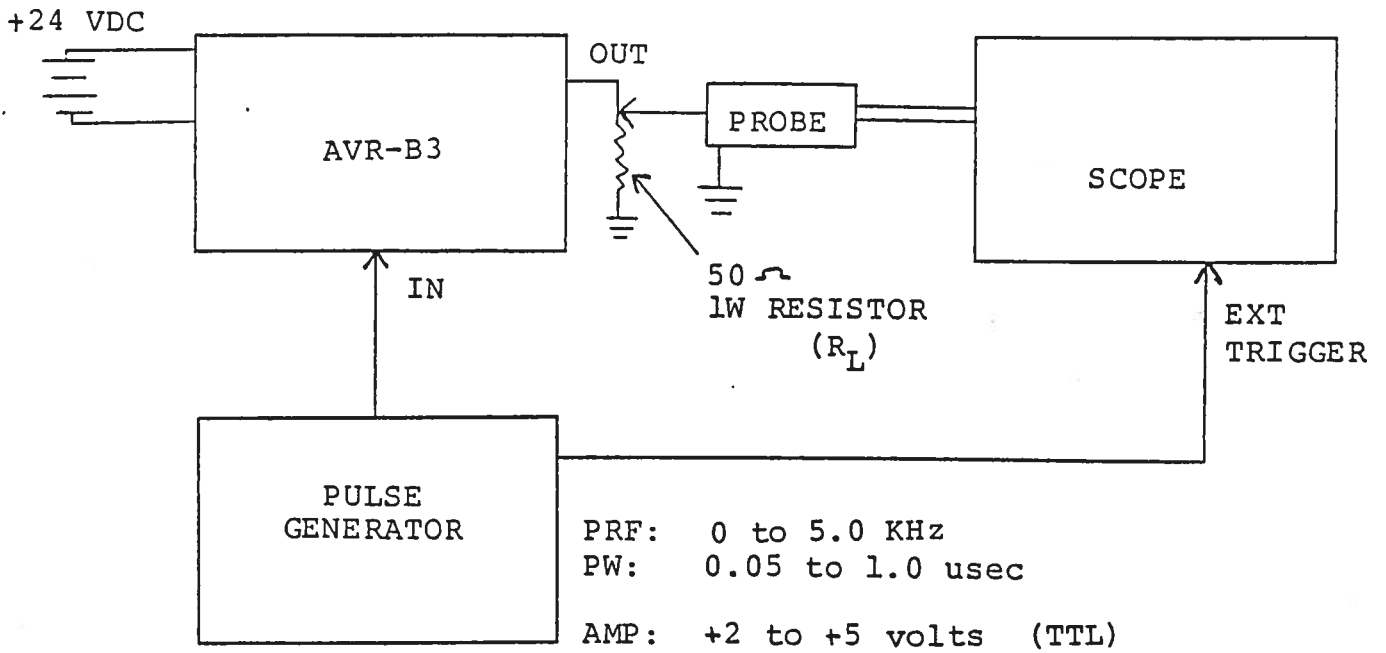

B.

GENERAL OPERATING INSTRUCTIONS

- 1) The equipment should be connected in the general fashion shown above. Since the AVR unit provides an output pulse rise time as low as 5 nsec a fast oscilloscope (at least 200 MHz) should be used to display the waveform.
- 2) The magnitude of the output pulse is controlled by the front panel one turn pot (AMP). Maximum clockwise rotation of the pot provides the maximum output. For units with the EA option, the output amplitude is controlled by 0 to +10 volt applied to the AMP solder terminal ( $R_{IN} \geq 10K$ ).
- 3) The output pulse width is controlled by the one turn PW pot. For units with the EW option, the output pulse width is controlled by 0 to +10 volt applied to the PW solder terminal ( $R_{IN} \geq 10K$ ).
- 4) In the event of severe overloading, the output switching elements (Avtech Part No. SL5) may fail. The SL5 units are readily replaced by removing the four screws which affix the small cover plate to the bottom of the AVR chassis. The four 2-56 counter sink screws are then removed. The SL5 units may then be extracted using needle nosed pliers. When replacing the SL5 units take care to ensure that the short lead is placed adjacent to the black dot on the AVR chassis.
- 5) The front panel TL switch controls the droop and decay time constant of the output pulse. In the LOW position the droop is about 10 times higher and the decay time constant is about 10 times shorter.

Applied Solar  
Change time constant  
08.10.88

-EA  
-EW