

**AVTECH ELECTROSYSTEMS LTD.**

**NANOSECOND WAVEFORM ELECTRONICS  
ENGINEERING . MANUFACTURING**

□ P.O. BOX 265  
OGDENSBURG  
NEW YORK  
13669  
(315) 472-5270

✕ BOX 5120 STN. "F"  
OTTAWA, ONTARIO  
CANADA K2C 3H4  
(613) 226-5772  
TELEX 053-4591

**INSTRUCTIONS**

**MODEL AVR-B3-C PULSE GENERATOR**

**S.N. :**

## WARRANTY

Avtech Electrosystems Ltd. warrants products of its manufacture to be free from defects in material and workmanship under conditions of normal use. If, within one year after delivery to the original owner, and after prepaid return by the original owner, this Avtech product is found to be defective, Avtech shall at its option repair or replace said defective item. This warranty does not apply to units which have been disassembled, modified or subjected to conditions exceeding the applicable specifications or ratings. This warranty is the extent of the obligation or liability assumed by Avtech with respect to this product and no other warranty or guarantee is either expressed or implied.

Fig. 1

PULSE GENERATOR TEST ARRANGEMENT

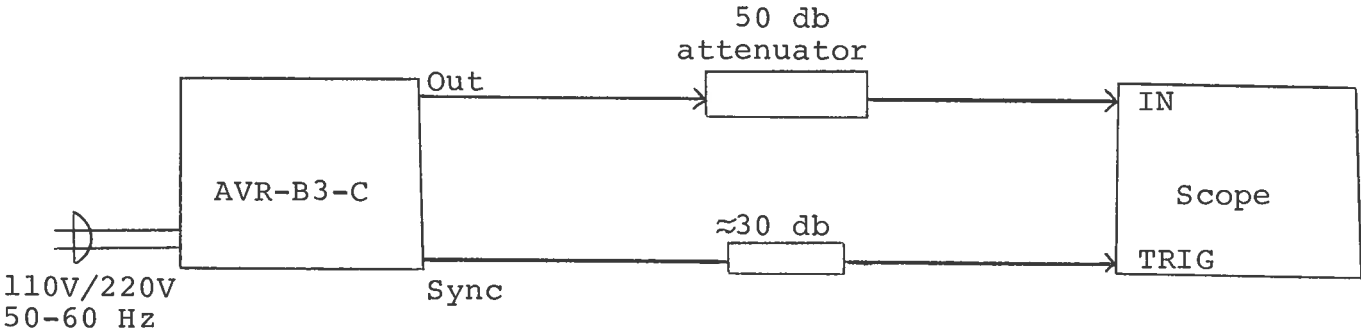

Notes:

- 1) The bandwidth capability of components and instruments used to display the pulse generator output signal (attenuators, cables, connectors, etc.) should exceed 200 MHz.
- 2) The use of 50 db attenuator at the scope vertical input channel will insure a peak input signal to the scope of less than one volt (necessary only if sampling scope used). If a high impedance real time scope is used, the pulse generator should be terminated using a shunt 50 ohm resistor.
- 3) The sync output channel provides TTL level signals. To avoid overdriving the TRIG input channel of some scopes, a 30 db attenuator should be placed at the input to the scope trigger channel.
- 4) To obtain a stable output display the PW and PRF controls on the front panel should be set maximum counter-clockwise while the front panel PRF RANGE switch may be in either range. The front panel TRIG toggle switch should be in the INT position. The DELAY controls and the scope triggering controls are then adjusted to obtain a stable output. The scope may then be used to set the desired PRF by rotating the PRF control and by means of the PRF RANGE switch.
- 5) The output pulse width is controlled by means of the front panel one turn PW control. The control should initially be set maximum counter-clockwise and the pulse width adjusted using an oscilloscope.
- 6) The output pulse amplitude is controlled by means of the front panel one turn AMP control.
- 7) To voltage control the output pulse width, remove the jumper wire between banana plugs A and B on the back panel and apply 0 to +10V to connector B ( $R_{IN} \geq 10K$ ). (option).
- 8) To voltage control the output amplitude, remove the jumper wire between banana plugs A and B on the back panel and apply 0 to +10V to connector B ( $R_{IN} \geq 10K$ ). (option).
- 9) An external clock may be used to control the output PRF of the AVR unit by setting the front panel TRIG toggle switch in the EXT position and applying a 0.2 usec (approx.) TTL level pulse to the TRIG BNC connector input. For operation in this mode, the scope time base must also be triggered by the external clock rather than from the SYNC output.

- 10) The AVR-B3 features an output impedance of the order of several ohms (rather than 50 ohms). The following consequences of this feature should be noted:
- a) When used to switch some semiconductor devices (eg. bipolar and VMOS power transistors), the AVR unit will yield much faster switching times than those provided by 50 ohm pulse generators.
  - b) The AVR unit will safely operate in to load impedances in the range of 50 ohms to an open circuit. However, the fall time may degrade for load impedances higher than fifty ohms.
  - c) The AVR unit may be effectively converted to a fifty ohm output impedance generator by placing a fifty ohm 1/2 watt carbon composition resistor in series with the output of the unit and the load. The maximum available load voltage will then decrease to 50 volts (from 100 volts).
  - d) The output switching elements may fail if the unit is inadvertently operated into a short circuit. The switching elements are easily replaced in the field following the procedure outlined in the REPAIR Section.

Fig. 2

FRONT PANEL CONTROLS

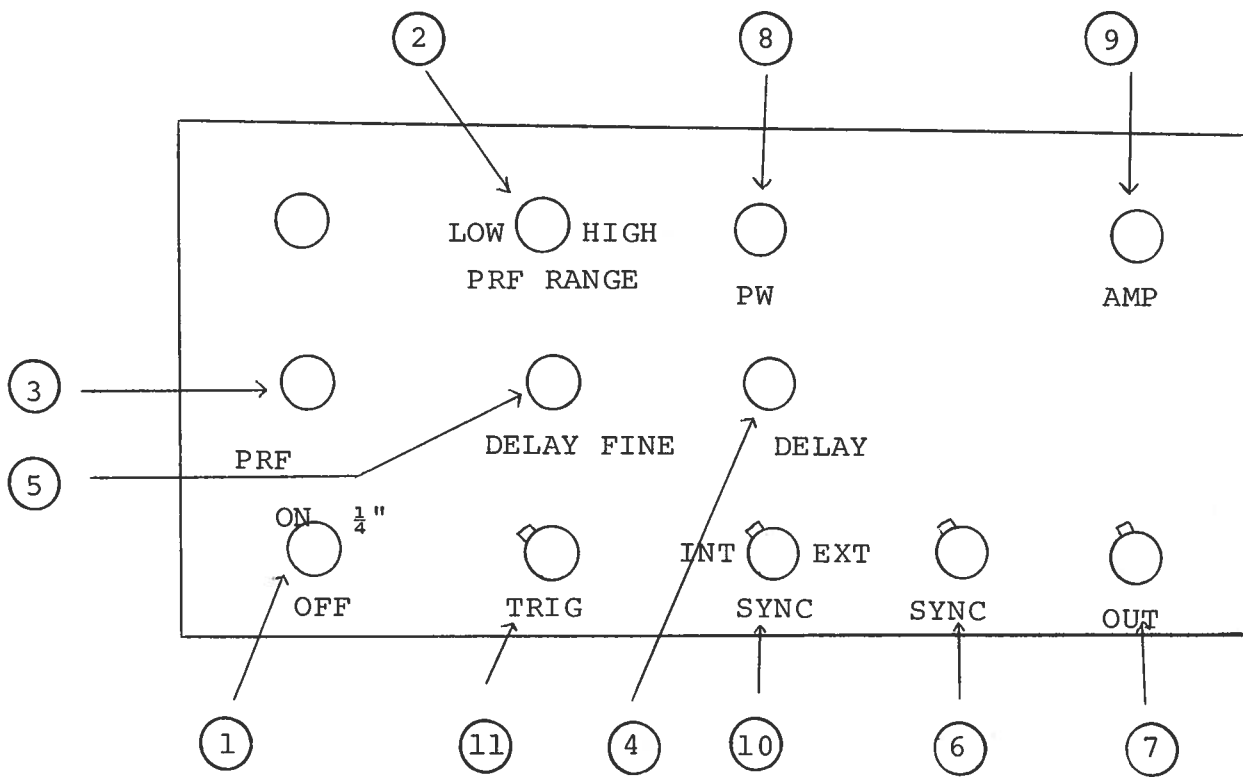

- (1) ON-OFF Switch. Applies basic prime power to all stages.
- (2) PRF Control. With the PRF RANGE switch in the low position, PRF control will vary PRF from 0.05 KHz to about 2.0 KHz. With the PRF RANGE switch in the high position, varies PRF from about 0.5 KHz to about 20 KHz.
- (3) PRF Control. With the PRF RANGE switch in the low position, PRF control will vary PRF from 0.05 KHz to about 2.0 KHz. With the PRF RANGE switch in the high position, varies PRF from about 0.5 KHz to about 20 KHz.
- (4) DELAY Control. Controls the relative delay between the reference output pulse provided at the SYNC output (6) the main output (7). This delay is variable over the range of 0 to at least 500 nsec.
- (5) DELAY FINE. As DELAY (4) but about 5 times less sensitive.
- (6) SYNC Output. This output precedes the main output (7) and is used to trigger the scope time base. The output is a TTL level 100 nsec (approx.) pulse capable of driving a fifty ohm load. The relative delay between the SYNC output and the main output is variable from 0 to 500 nsec using the DELAY controls.
- (7) OUT Connector. BNC connector provides output to a fifty ohm load.
- (8) PW Control. A one turn control which varies the output pulse width from 20 to 200 usec.
- (9) AMP Control. A one turn control which varies the output pulse amplitude from 0 to 100 V to a fifty ohm load.
- (10) EXT-INT Control. With this toggle switch in the INT position, the PRF of the AVR unit is controlled via an internal clock which in turn is controlled by the PRF and PRF FINE controls. With the toggle switch in the EXT position, the AVR unit requires a 0.2 usec TTL level pulse applied at the TRIG input in order to trigger the output stages. In addition, in this mode, the scope time base must be triggered by the external trigger source.
- (11) TRIG Input. The external trigger signal is applied at this input when the EXT-INT toggle switch is in the EXT position.

Fig. 3

BACK PANEL CONTROLS

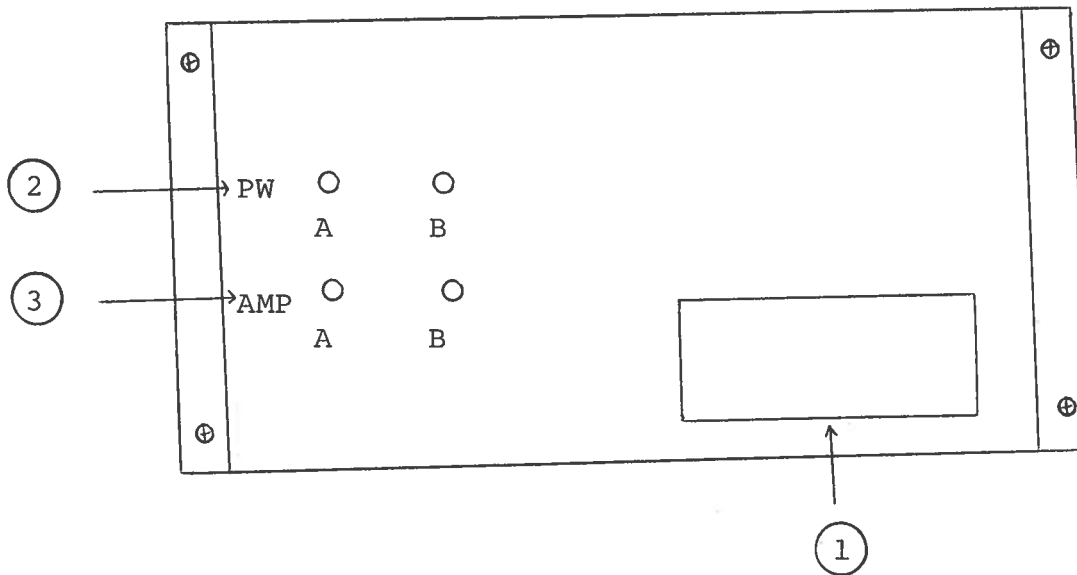



- (1) FUSED CONNECTOR, VOLTAGE SELECTOR. The detachable power cord is connected at this point. In addition, the removable cord is adjusted to select the desired input operating voltage. The unit also contains the main power fuse.
- (2) To voltage control the output pulse width, remove the jumper wire between banana plugs A and B and apply 0 to +10V to connector B ( $R_{IN} \gg 10K$ ). (option).
- (3) To voltage control the output amplitude, remove the jumper wire between banana plugs A and B and apply 0 to +10V to connector B ( $R_{IN} \gg 10K$ ). (option).

Fig. 4

SYSTEM BLOCK DIAGRAM

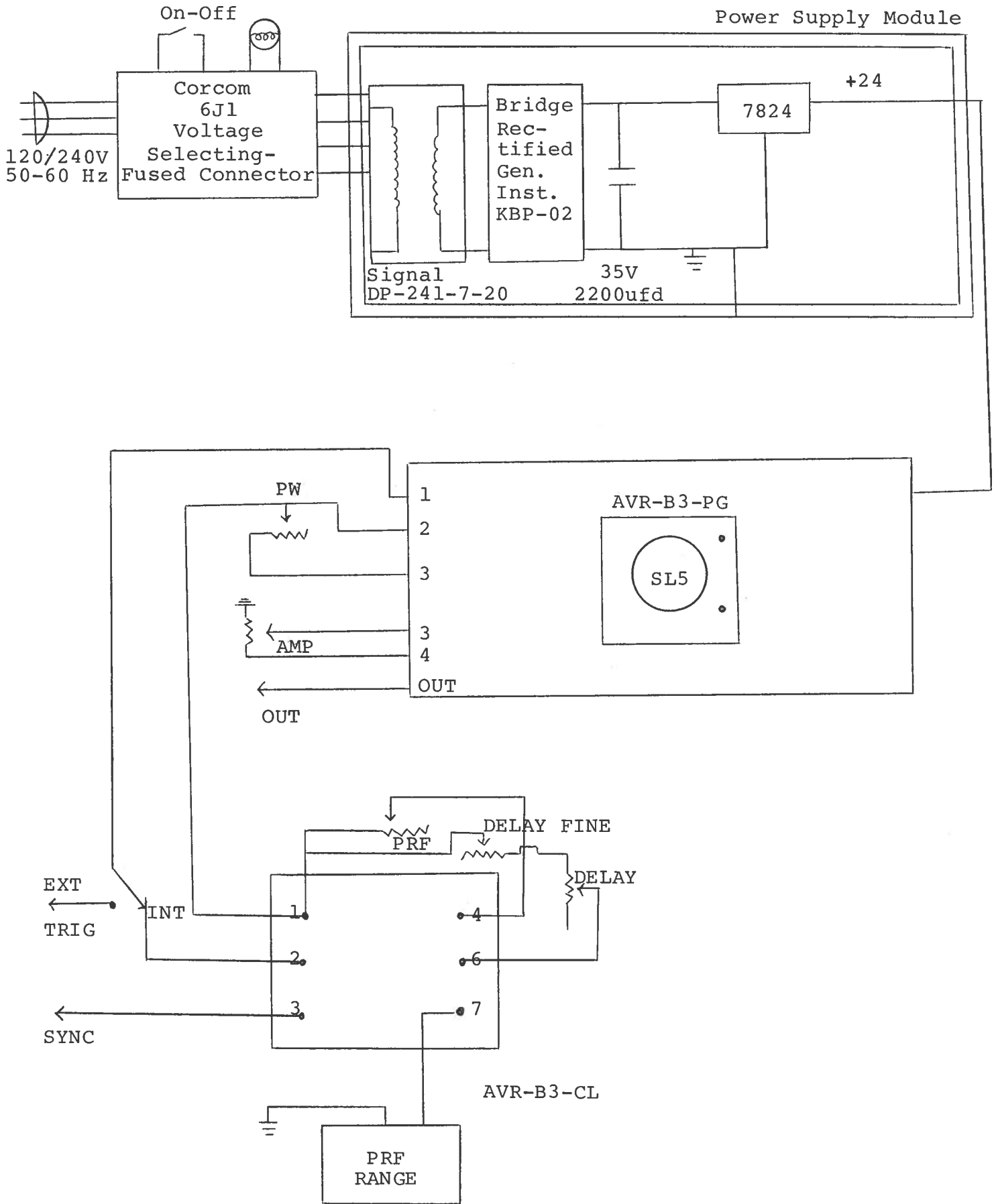
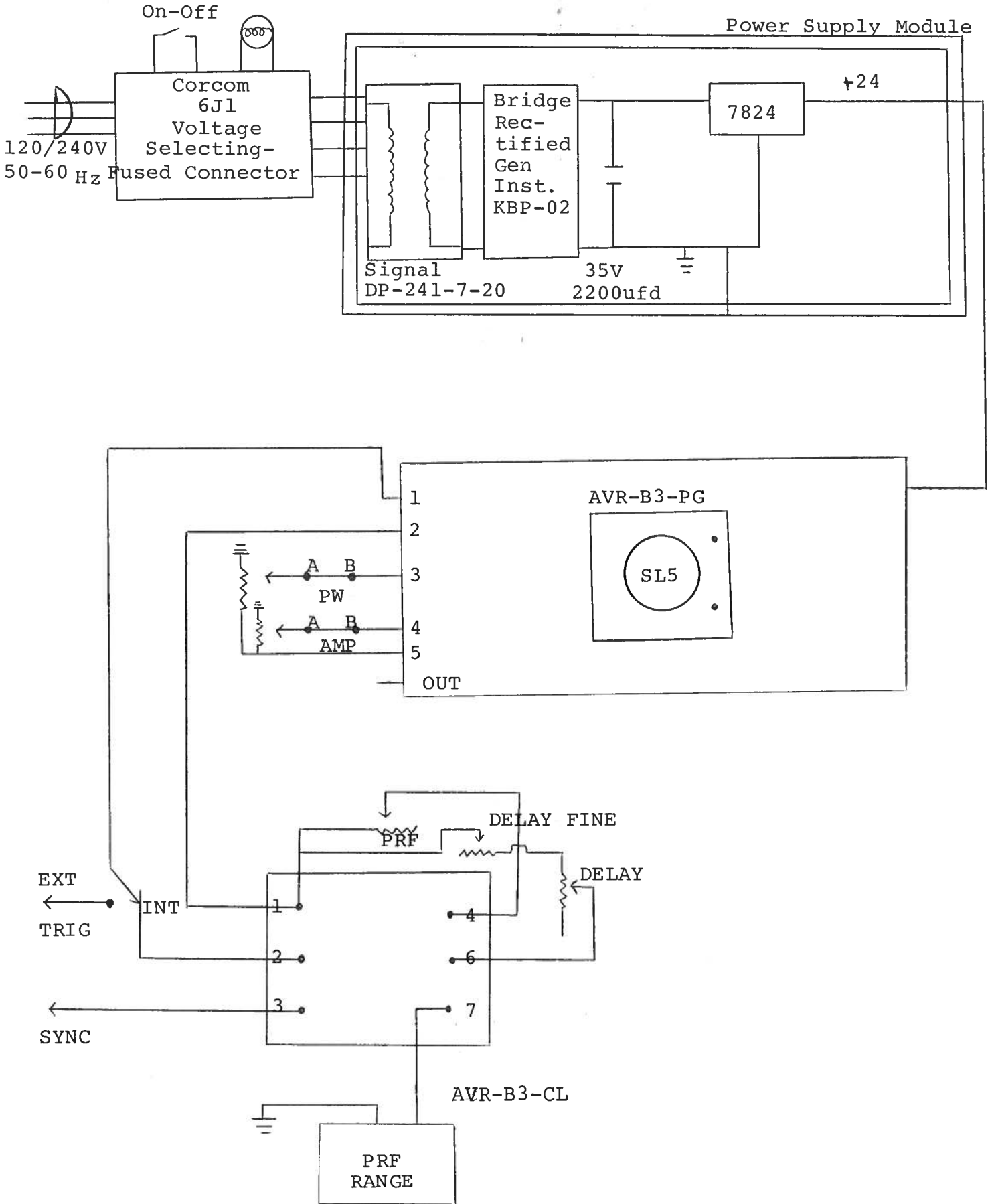

Fig. 5

SYSTEM BLOCK DIAGRAM

(EA-EW OPTION UNITS)



## SYSTEM DESCRIPTION AND REPAIR PROCEDURE

The AVR-B3-C consists of the following basic modules:

- 1) AVR-B3-PG pulse generator module
- 2) AVR-B3-CL clock module
- 3) +24V power supply board

The modules are interconnected as shown in Fig. 4. The clock module controls the output PRF and the relative delay between the main output and the SYNC outputs. The PW pulse generator module generate the output pulse. In the event of an instrument malfunction, it is most likely that some of the output switching elements (SL5) may have failed due to an output short circuit condition or to a high duty cycle condition. The switching elements may be accessed by removing the cover plate on the bottom side of the instrument. NOTE: First turn off the prime power. The elements may be removed from their sockets by means of a needle nosed pliers. The SL5 is a selected VMOS power transistor in a TO 220 packages and may be checked on a curve tracer. If defective, replacement units should be ordered directly from Avtech. When replacing the SL5 switching elements, take care to insure that the short lead (of the three leads) is adjacent to the black dot on the chassis. If the switching elements are not defective, then the four Phillips screws on the back panel should be removed. The top cover may then be slid off and operation of the clock and power supply modules should be checked. The clock module is functioning properly if:

- a) 0.1 usec TTL level outputs are observed at pins 2 and 3.
- b) The PRF of the outputs can be varied over the range of 0.1 KHz to 0.1 MHz using the PRF, PRF FINE and PRF RANGE controls.
- c) The relative delay between the pin 2 and 3 outputs can be varied by at least 500 nsec by the DELAY controls.

The sealed clock module must be returned to Avtech for repair or replacement if the above conditions are not observed. The power supply board generates +24V DC to power the other modules. If the voltage is less than +24V, turn off the prime power and unsolder the lead from the 7824 regulator chip on the power supply board. Solder a 100 ohm 5 watt resistor to the 7824 output to ground and turn on the prime power. A voltage of +24 volts should be read. If the voltage is less then the power supply board is defective and should be repaired or replaced.

Schroff

06.07.84

-EA  
-EW

the following details of the...  
1. 450-1111 is...  
2. 450-1112 is...  
3. 450-1113 is...

The following details of the...  
1. 450-1111 is...  
2. 450-1112 is...  
3. 450-1113 is...  
4. 450-1114 is...  
5. 450-1115 is...  
6. 450-1116 is...  
7. 450-1117 is...  
8. 450-1118 is...  
9. 450-1119 is...  
10. 450-1120 is...

The following details of the...  
1. 450-1121 is...  
2. 450-1122 is...  
3. 450-1123 is...

The following details of the...  
1. 450-1124 is...  
2. 450-1125 is...  
3. 450-1126 is...  
4. 450-1127 is...  
5. 450-1128 is...  
6. 450-1129 is...  
7. 450-1130 is...