



AVTECH ELECTROSYSTEMS LTD.  
NANOSECOND WAVEFORM ELECTRONICS

---

□ P.O. BOX 265  
OGDENSBURG, NY  
U.S.A. 13669-0265  
TEL: (315) 472-5270  
FAX: (613) 226-2802

✕ BOX 5120 STN. F  
OTTAWA, ONTARIO  
CANADA K2C 3H4  
TEL: (613) 226-5772  
FAX: (613) 226-2802

INSTRUCTIONS

MODEL AVR-D2-C PULSE GENERATOR

S.N. :

## WARRANTY

Avtech Electrosystems Ltd. warrants products of its manufacture to be free from defects in material and workmanship under conditions of normal use. If, within one year after delivery to the original owner, and after prepaid return by the original owner, this Avtech product is found to be defective, Avtech shall at its option repair or replace said defective item. This warranty does not apply to units which have been disassembled, modified or subjected to conditions exceeding the applicable specifications or ratings. This warranty is the extent of the obligation or liability assumed by Avtech with respect to this product and no other warranty or guarantee is either expressed or implied.

Fig. 1

PULSE GENERATOR TEST ARRANGEMENT

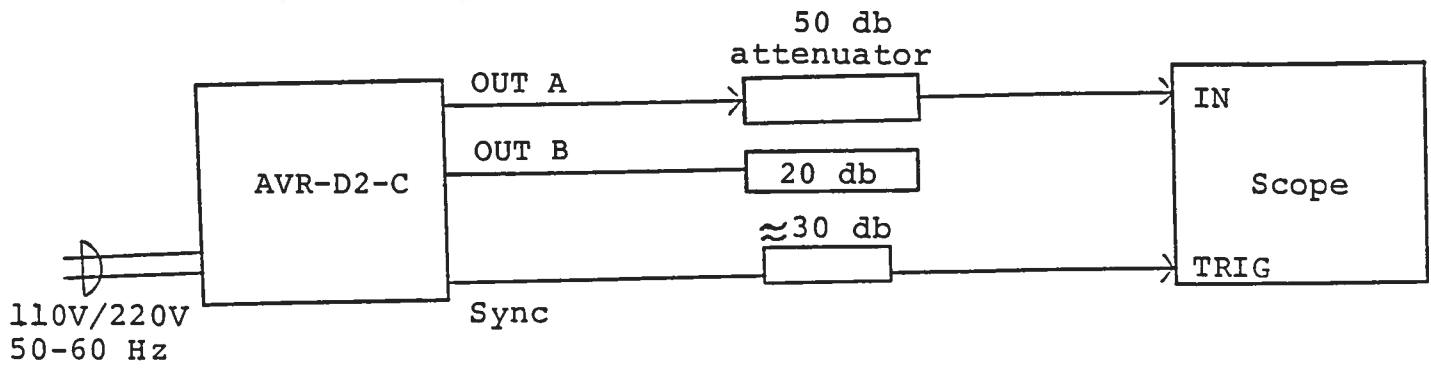

Notes:

- 1) The bandwidth capability of components and instruments used to display the pulse generator output signal (attenuators, cables, connectors, etc.) should exceed 1000 MHz.
- 2) The use of 50 db attenuator (for channel A but 20 db for channel B) at the scope vertical input channel will insure a peak input signal to the scope of less than one volt (necessary only if sampling scope used). If a high impedance real time scope is used, the pulse generator should be terminated using a shunt 50 ohm resistor. Note that channel A and B both require 50 ohm termination when operating.
- 3) The sync output channel provides TTL level signals. To avoid overdriving the TRIG input channel of some scopes, a 30 db attenuator should be placed at the input to the scope trigger channel. The SYNC output precedes the main output when the front panel LEAD-LAG switch is in the LEAD position. The SYNC output lags the main output when the switch is in the LAG position.
- 4) The desired output polarity is selected by means of the front panel POLARITY switch.
- 5) To obtain a stable output display the PW and PRF controls on the front panel should be set mid range. The front panel TRIG toggle switch should be in the INT position. The DELAY controls and the scope triggering controls are then adjusted to obtain a stable output. The scope may then be used to set the desired PRF by rotating the PRF controls.
- 6) CAUTION: The output duty cycle for the A output must not exceed 10% (or the output stage may be damaged). For example, at the maximum pulse width of 20 us, the PRF must not exceed 5 KHz. For pulse width of 2 us or less the PRF may be as high as 50 KHz.

AVR units with a serial number higher than 5600 are protected by an automatic overload protective circuit which controls the front panel overload light. If the unit is overloaded (by operating at an exceedingly high duty cycle or by operating into a short circuit), the protective circuit will turn the output of the instrument OFF and turn the indicator light ON. The light will stay ON (i.e. output OFF) for about 5 seconds after which the instrument will attempt to turn ON (i.e. light OFF) for about 1 second. If the overload condition persists, the instrument will turn OFF again (i.e. light ON) for another 5 seconds. If the overload

condition has been removed, the instrument will turn on and resume normal operation. Overload conditions may be removed by:

- 1) Reducing PRF (i.e. switch to a lower range)
  - 2) Reducing pulse width (i.e. switch to a lower range)
  - 3) Removing output load short circuit (if any)
- 7) The output pulse width for output A is controlled by means of the front panel ten turn PW A control. The pulse width for the B output is fixed at 15 nsec.
  - 8) The output pulse amplitude for output A is controlled by means of the front panel ten turn AMP A control. The amplitude for the B output is fixed at 2 volts.
  - 9) The DC offset to outputs A and B is controlled by the 10 turn front panel offset control and the two position offset ON-OFF switch. Note that the DC offset is zero for the pot control set near mid range while the offset magnitude is maximum for the pot fully CW or fully CCW.
  - 10) An external clock may be used to control the output PRF of the AVR unit by setting the front panel TRIG toggle switch in the EXT position and applying a 0.2 usec (approx.) TTL level pulse to the TRIG BNC connector input. For operation in this mode, the scope time base must also be triggered by the external clock rather than from the SYNC output.
  - 11) CAUTION:
    - a) Both outputs A and B are designed to operate into 50 ohms so the switching time test circuit should present an input resistance of this magnitude.
    - b) At maximum duty cycle, output A will provide nearly 2 watts average power so the test circuit must be capable of dissipating this power.
    - c) The DC offset on output A will provide up to 4.5 watts to a DC load of 50 ohms. It may be necessary to place DC blocking capacitors in the test circuit to limit the DC power dissipation.
    - d) An audible hum may be evident when the DC offset is set near maximum for output A and the output pulse width is near maximum. This hum is normal.
  - 12) EA Option. To voltage control the output amplitude of channel A, set the rear panel AMP switch in the EXT position and apply 0 to +10 volts between terminal A and ground ( $R_{IN} > 10K$ ).

- 13) EW Option. To voltage control the output pulse width of channel A, set the rear panel PW switch in the EXT position and apply 0 to +10 volts between terminal A and ground ( $R_{IN} > 10K$ ).
- 14) EO Option. To voltage control the DC offset on channel A or B, set the rear panel OS switch in the EXT position and apply 0 to +10 volts between terminal A and ground ( $R_{IN} > 10K$ ).
- 15) EP Option. To voltage control the output polarity of channel A or B, set the rear panel POL switch in the EXT position and apply 0 or +5 volts between terminal A and ground ( $R_{IN} > 10K$ ). 0 volts will provide a negative output pulse while +5 volts will provide a positive output pulse.
- 16) MA option. The monitor output (-M) provides a 20 db attenuated coincident replica of the channel A output.
- 17) The unit can be converted from 120 to 240V 50-60 Hz operation by adjusting the voltage selector card in the rear panel fused voltage selector-cable connector assembly.

Fig. 2

FRONT PANEL CONTROLS

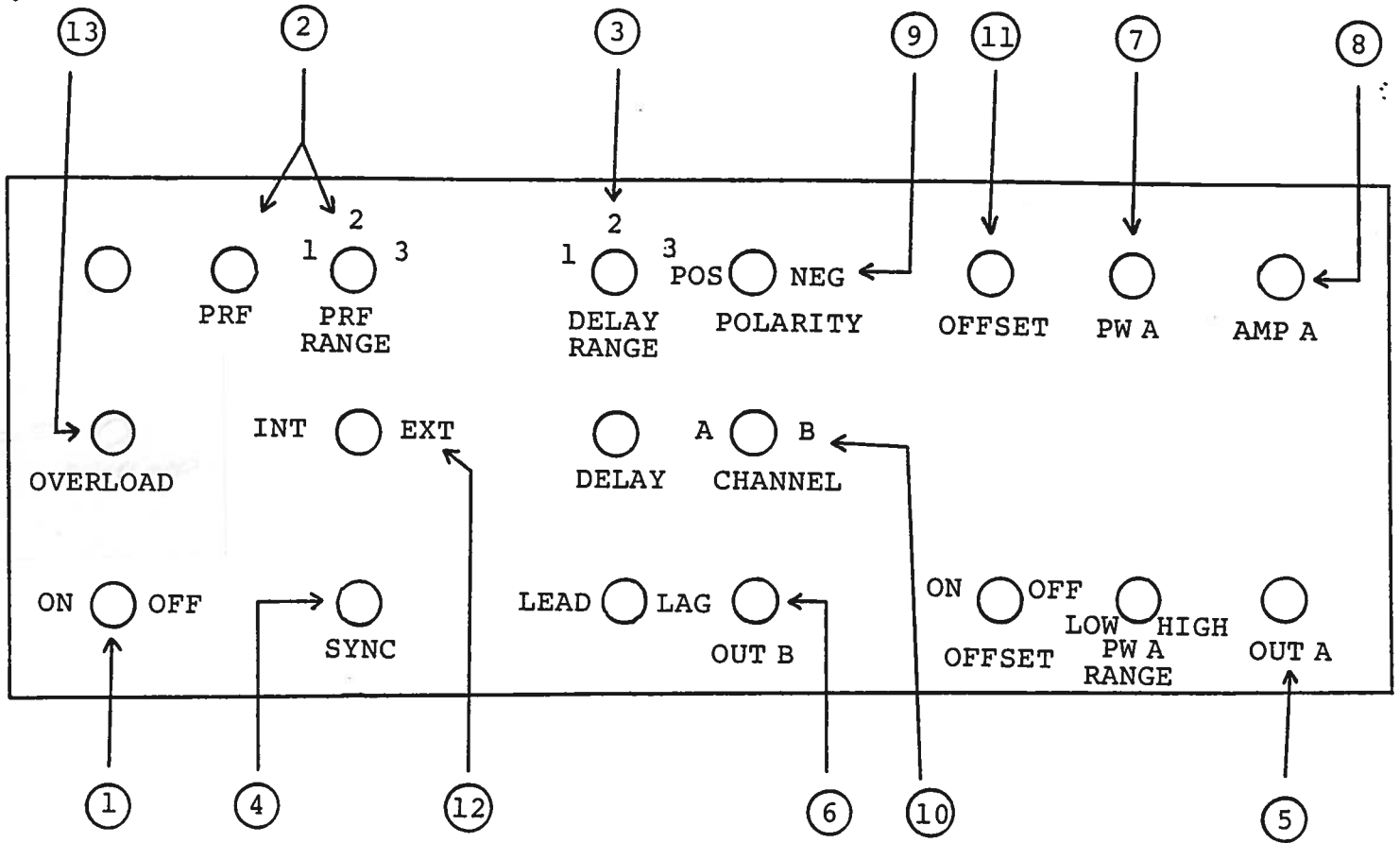

- (1) ON-OFF Switch. Applies basic prime power to all stages.
- (2) PRF Control. Controls PRF as follows:

RANGE 1	50 Hz	to	500 Hz
RANGE 2	500 Hz	to	5 KHz
RANGE 3	5 KHz	to	50 KHz
- (3) DELAY Control. Controls the relative delay between the reference output pulse provided at the SYNC output (4) and the main outputs (5) and (6). This delay is variable over the range of 0 to about 20.0 usec. The SYNC output precedes the main output when the LEAD-LAG switch is in the LEAD position and lags when the switch is in the LAG position.
- (4) SYNC Output. This output is used to trigger the scope time base. The output is a TTL level 100 nsec (approx.) pulse capable of driving a fifty ohm load.
- (5) OUT A Connector. BNC connector provides output to a fifty ohm load.
- (6) OUT B Connector. BNC connector provides output to a fifty ohm load.
- (7) PW A Control. A ten turn control and two position range switch which varies the output pulse width from 100 nsec to 20 usec.
- (8) AMP A Control. A one turn control which varies the output pulse amplitude from 0 to 30 V to a fifty ohm load.
- (9) POLARITY Control. Controls polarity of output pulse.
- (10) Channel selector. With two position switch in A position output A is active and output B is off. With switch in B position the output B is only active.
- (11) The DC offset to outputs A and B is controlled by the 10 turn front panel offset control and the two position offset ON-OFF switch. Note that the DC offset is zero for the pot control set near mid range while the offset magnitude is maximum for the pot fully CW or fully CCW. The max DC offset for channel A is 0 to  $\pm 15$  volts while the range for channel B is 0 to  $\pm 1$  volt.
- (12) EXT-INT Control. With this toggle switch in the INT position, the PRF of the AVR unit is controlled via an internal clock which in turn is controlled by the PRF and PRF FINE controls. With the toggle switch in the EXT position, the AVR unit requires a 0.1 usec TTL level pulse applied at the TRIG input in order to trigger the output stages. In addition, in this mode, the scope time base must be triggered by the external trigger source.



(13) OVERLOAD. AVR units with a serial number higher than 5600 are protected by an automatic overload protective circuit which controls the front panel overload light. If the unit is overloaded (by operating at an exceedingly high duty cycle or by operating into a short circuit), the protective circuit will turn the output of the instrument OFF and turn the indicator light ON. The light will stay ON (i.e. output OFF) for about 5 seconds after which the instrument will attempt to turn ON (i.e. light OFF) for about 1 second. If the overload condition persists, the instrument will turn OFF again (i.e. light ON) for another 5 seconds. If the overload condition has been removed, the instrument will turn on and resume normal operation. Overload conditions may be removed by:

- 1) Reducing PRF (i.e. switch to a lower range)
- 2) Reducing pulse width (i.e. switch to a lower range)
- 3) Removing output load short circuit (if any)

Fig. 3

BACK PANEL CONTROLS

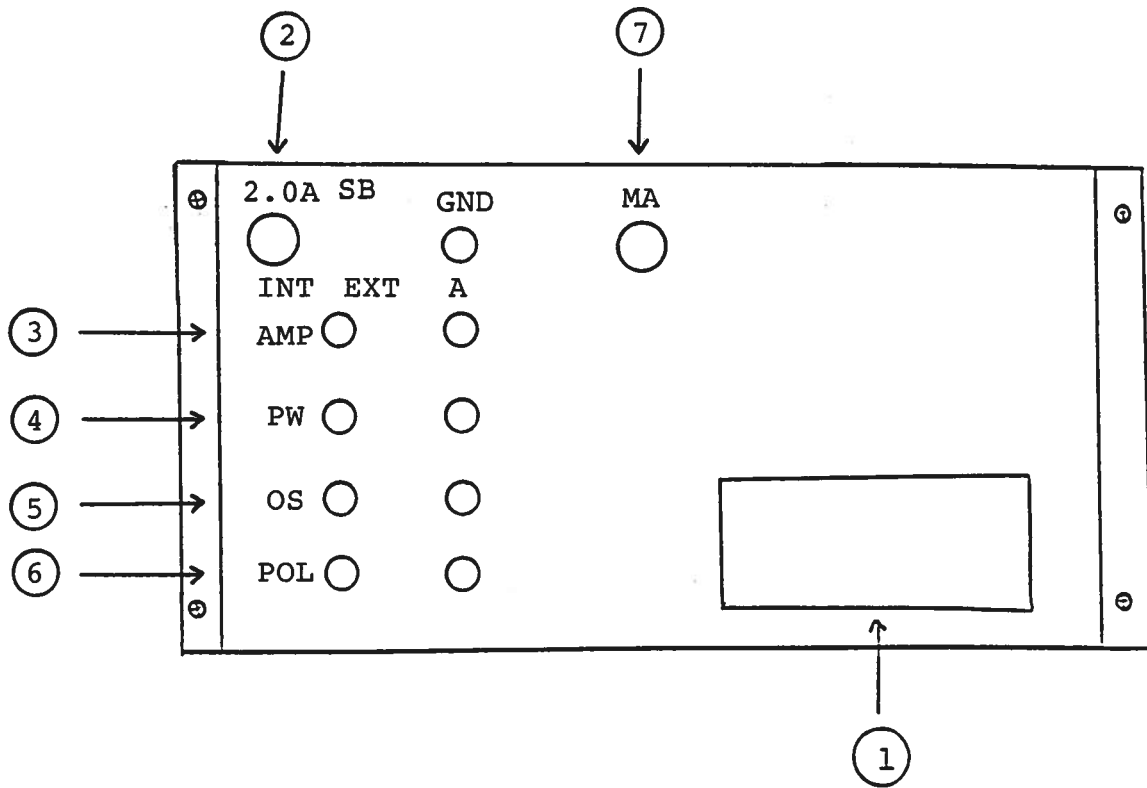

- (1) FUSED CONNECTOR, VOLTAGE SELECTOR. The detachable power cord is connected at this point. In addition, the removable cord is adjusted to select the desired input operating voltage (120/240V, 50-60 Hz). The unit also contains the main power fuse (0.5A SB).
- (2) 2.0A SB. Fuse which protects the output stage if the output duty cycle rating is exceeded.
- (3) EA Option. To voltage control the output amplitude of channel A, set the rear panel AMP switch in the EXT position and apply 0 to +10 volts between terminal A and ground ( $R_{IN} > 10K$ ).
- (4) EW Option. To voltage control the output pulse width of channel A, set the rear panel PW switch in the EXT position and apply 0 to +10 volts between terminal A and ground ( $R_{IN} > 10K$ ).
- (5) EO Option. To voltage control the DC offset on channel A or B, set the rear panel OS switch in the EXT position and apply 0 to +10 volts between terminal A and ground ( $R_{IN} > 10K$ ).
- (6) EP Option. To voltage control the output polarity of channel A or B, set the rear panel POL switch in the EXT position and apply 0 or +5 volts between terminal A and ground ( $R_{IN} > 10K$ ). 0 volts will provide a negative output pulse while +5 volts will provide a positive output pulse.
- (7) MA option. The monitor output (-M) provides a 20 db attenuated coincident replica of the channel A output.

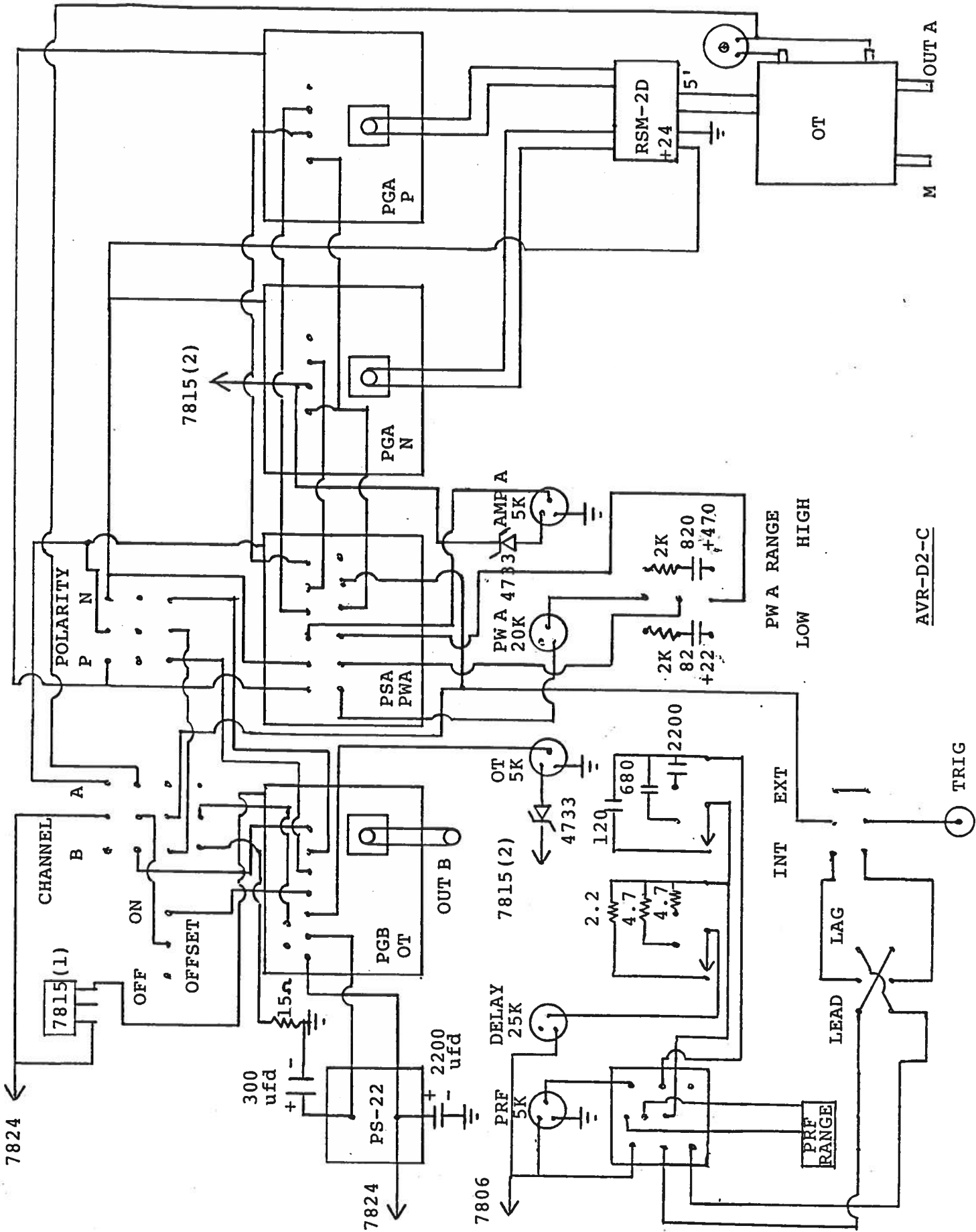

AVR-D2-C

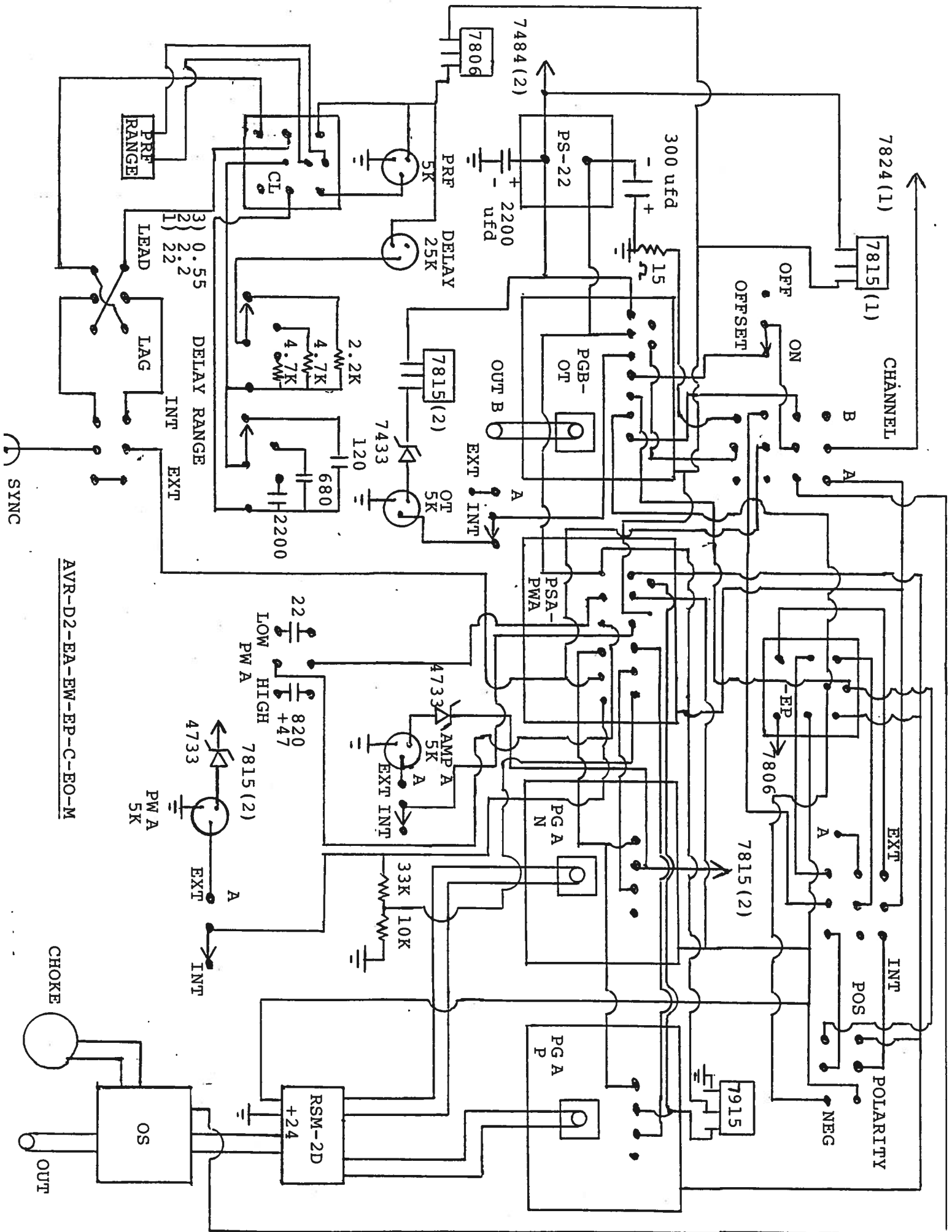

AVR-D2-EA-EW-EP-C-EO-M

## SYSTEM DESCRIPTION AND REPAIR PROCEDURE

The AVR-D2-C consists of the following basic modules:

- 1) AVR-D2-PGA pulse generator modules (-P and -N)
- 2) AVR-D2-PSA-PWA power supply module
- 3) AVR-D2-PGB-OT pulse generator-offset module
- 4) AVR-D2-PS-22 power supply module
- 5) AVR-D2-OS offset module
- 6) AVR-D2-CL clock module
- 7) +24V power supply board

The modules are interconnected as shown in Fig. 4. The clock module controls the output PRF and the relative delay between the main output and the SYNC outputs. The PG pulse generator modules generate the output pulse. In the event of an instrument malfunction, it is most likely that the rear panel 2.0A SB fuse or some of the output switching elements (SL5T) may have failed due to an output short circuit condition or to a high duty cycle condition. The switching elements may be accessed by removing the cover plates on the bottom side of the instrument. NOTE: First turn off the prime power. The elements may be removed from their sockets by means of a needle nosed pliers. The SL5T is a selected VMOS power transistor in a TO 220 packages and may be checked on a curve tracer. If defective, replacement units should be ordered directly from Avtech. When replacing the SL5T switching elements, take care to insure that the short lead (of the three leads) is adjacent to the black dot on the chassis. If the switching elements are not defective, then the four Phillips screws on the back panel should be removed. The top cover may then be slid off and operation of the clock and power supply modules should be checked. The clock module is functioning properly if:

- a) 0.1 usec TTL level outputs are observed at pins 2 and 3.
- b) The PRF of the outputs can be varied over the range of 50 Hz to 50 KHz using the PRF controls.
- c) The relative delay between the pin 2 and 3 outputs can be varied by at least 20 usec by the DELAY controls.

The sealed clock module must be returned to Avtech for repair or replacement if the above conditions are not observed. The power supply board generates +24V DC to power the other modules. If the voltage is less than +24V, turn off the prime power and unsolder the lead from the 7824 regulator chip on the power supply board. Solder a 100 ohm 5 watt resistor to the 7824 output to ground and turn on the prime power. A voltage of +24 volts should be read. If the voltage is less then the power supply board is defective and should be repaired or replaced.

Schroff

05.28.91

edition B

-PN

-EA

-EW

-EO

-EP

-M