



**AVTECH ELECTROSYSTEMS LTD.**

NANOSECOND WAVEFORM ELECTRONICS  
SINCE 1975

P.O. BOX 265  
OGDENSBURG, NY  
U.S.A. 13669-0265  
TEL: (315) 472-5270  
FAX: (613) 226-2802

TEL: 1-800-265-6681  
FAX: 1-800-561-1970  
U.S.A. & CANADA

e-mail: [info@avtechpulse.com](mailto:info@avtechpulse.com)

BOX 5120 STN. F  
OTTAWA, ONTARIO  
CANADA K2C 3H4  
TEL: (613) 226-5772  
FAX: (613) 226-2802

INSTRUCTIONS

MODEL AVR-E2-PS PULSE GENERATOR

S.N. :

### WARRANTY

Avtech Electrosystems Ltd. warrants products of its manufacture to be free from defects in material and workmanship under conditions of normal use. If, within one year after delivery to the original owner, and after prepaid return by the original owner, this Avtech product is found to be defective, Avtech shall at its option repair or replace said defective item. This warranty does not apply to units which have been disassembled, modified or subjected to conditions exceeding the applicable specifications or ratings. This warranty is the extent of the obligation or liability assumed by Avtech with respect to this product and no other warranty or guarantee is either expressed or implied.

Fig. 1

TEST ARRANGEMENT

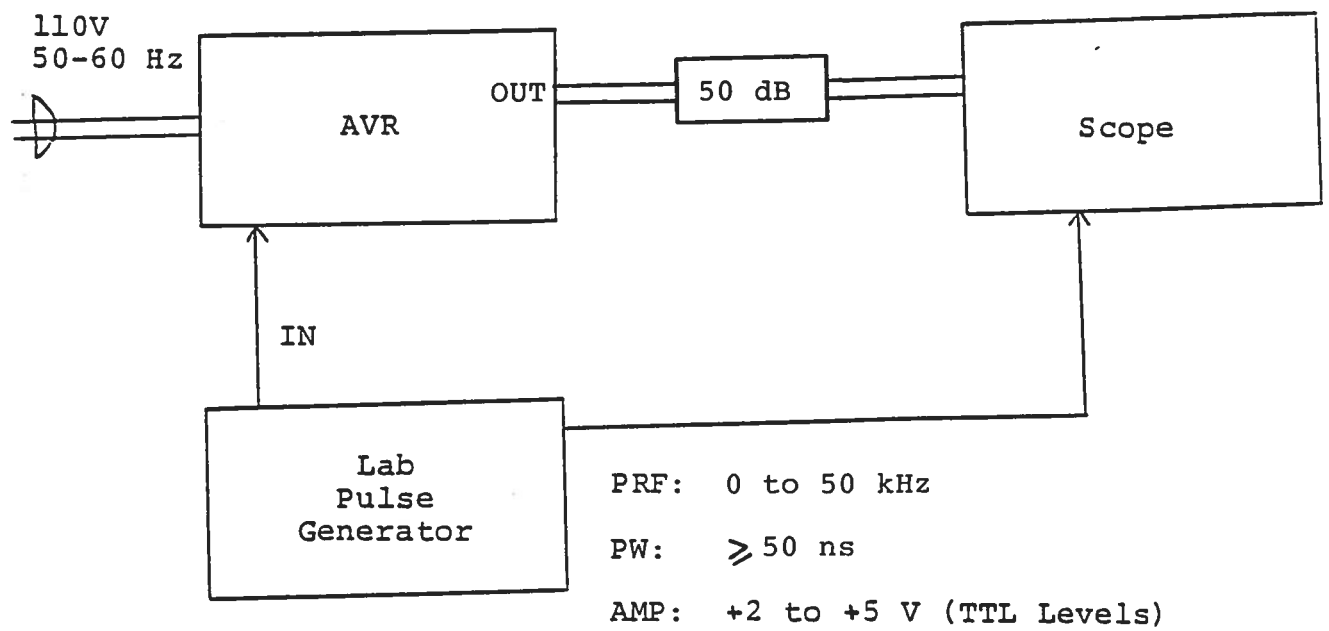

Notes:

- 1) The bandwidth capability of components and instruments used to display the pulse generator output signal (attenuators, cables, connectors, etc.) should exceed 2 GHz.
- 2) The use of 50 dB attenuator at the scope vertical input channel will insure a peak input signal to the scope of less than one Volt (necessary only if sampling scope used). If a high impedance real time scope is used, the pulse generator should be terminated using a shunt 50 Ohm resistor.
- 3) An external clock may be used to control the output PRF of the AVR unit by applying a 50 ns (or wider) TTL level pulse to the "IN" connector input.
- 4) The output pulse width is controlled by means of the front panel one turn PW control. To voltage control the pulse width, set the rear panel switch in the EXT position and apply 0 to +10 Volts to the A BNC connector ( $R_{IN} \geq 10K$ ). (option).
- 5) PW LOCK: Note that due to the digital nature of the EW option, some pulse width jitter may be observed at certain settings of the PW pot. This jitter may be removed by setting the rear panel PW LOCK switch in the ON position. When in the ON position, the pulse becomes frozen and will not change (as the PW pot is adjusted) until the switch is placed in the OFF position.
- 6) The output pulse amplitude is controlled by means of the front panel one turn AMP control. To voltage control the output, set the rear panel switch in the EXT position and apply 0 to +10 Volts to the A BNC connector ( $R_{IN} \geq 10K$ ). (option).

7) AVR units with a serial number higher than 5600 are protected by an automatic overload protective circuit which controls the front panel overload light. If the unit is overloaded (by operating at an exceedingly high duty cycle or by operating into a short circuit), the protective circuit will turn the output of the instrument OFF and turn the indicator light ON. The light will stay ON (i.e. output OFF) for about 5 seconds after which the instrument will attempt to turn ON (i.e. light OFF) for about 1 second. If the overload condition persists, the instrument will turn OFF again (i.e. light ON) for another 5 seconds. If the overload condition has been removed, the instrument will turn on and resume normal operation. Overload conditions may be removed by:

- 1) Reducing PRF (i.e. switch to a lower range)
- 2) Reducing pulse width (i.e. switch to a lower range)
- 3) Removing output load short circuit (if any)

Note that the light may illuminate when the prime power is applied. The light will extinguish after a few seconds and the unit will then operate normally.

8) The unit can be converted from 110 to 220V 50-60 Hz operation by adjusting the voltage selector card in the rear panel fused voltage selector-cable connector assembly.

9) For additional assistance:

Tel: (613) 226-5772  
Fax: (613) 226-2802

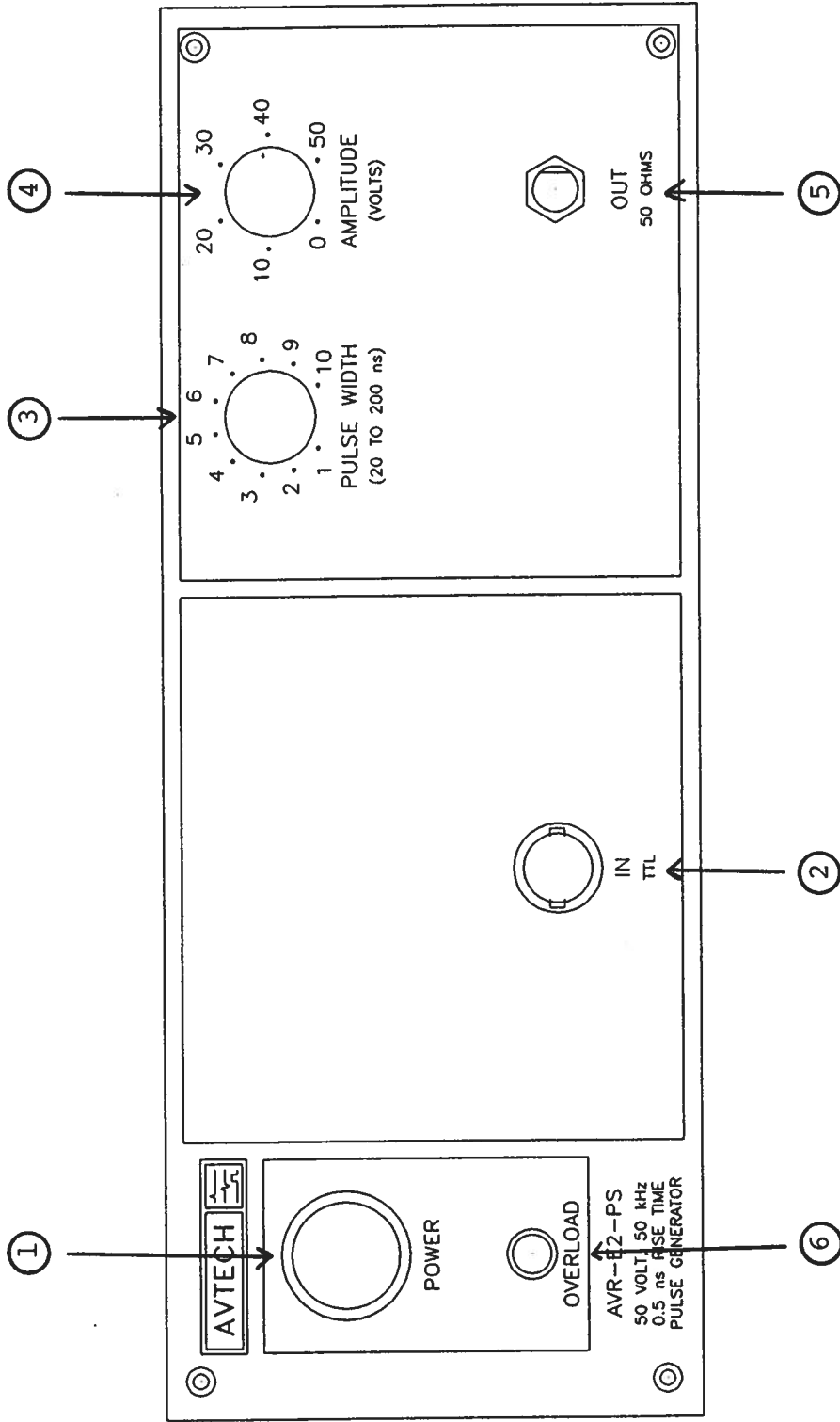

FRONT PANEL CONTROLS

Fig. 2

- (1) ON-OFF Switch. Applies basic prime power to all stages.
- (2) IN TTL. The AVR unit requires a 50 ns (or wider) TTL level pulse applied at the TRIG input in order to trigger the output stages.
- (3) PW Control. A one turn control which varies the output pulse width from 20 ns to 200 ns.
- (4) AMP Control. A one turn control which varies the output pulse amplitude to a fifty Ohm load.
- (5) OUT Connector. SMA connector provides output to a fifty Ohm load.
- (6) OVERLOAD. AVR units with a serial number higher than 5600 are protected by an automatic overload protective circuit which controls the front panel overload light. If the unit is overloaded (by operating at an exceedingly high duty cycle or by operating into a short circuit), the protective circuit will turn the output of the instrument OFF and turn the indicator light ON. The light will stay ON (i.e. output OFF) for about 5 seconds after which the instrument will attempt to turn ON (i.e. light OFF) for about 1 second. If the overload condition persists, the instrument will turn OFF again (i.e. light ON) for another 5 seconds. If the overload condition has been removed, the instrument will turn on and resume normal operation. Overload conditions may be removed by:
  - 1) Reducing PRF (i.e. switch to a lower range)
  - 2) Reducing pulse width (i.e. switch to a lower range)
  - 3) Removing output load short circuit (if any)

Note that the light may illuminate when the prime power is applied. The light will extinguish after a few seconds and the unit will then operate normally.

Fig. 3

BACK PANEL CONTROLS

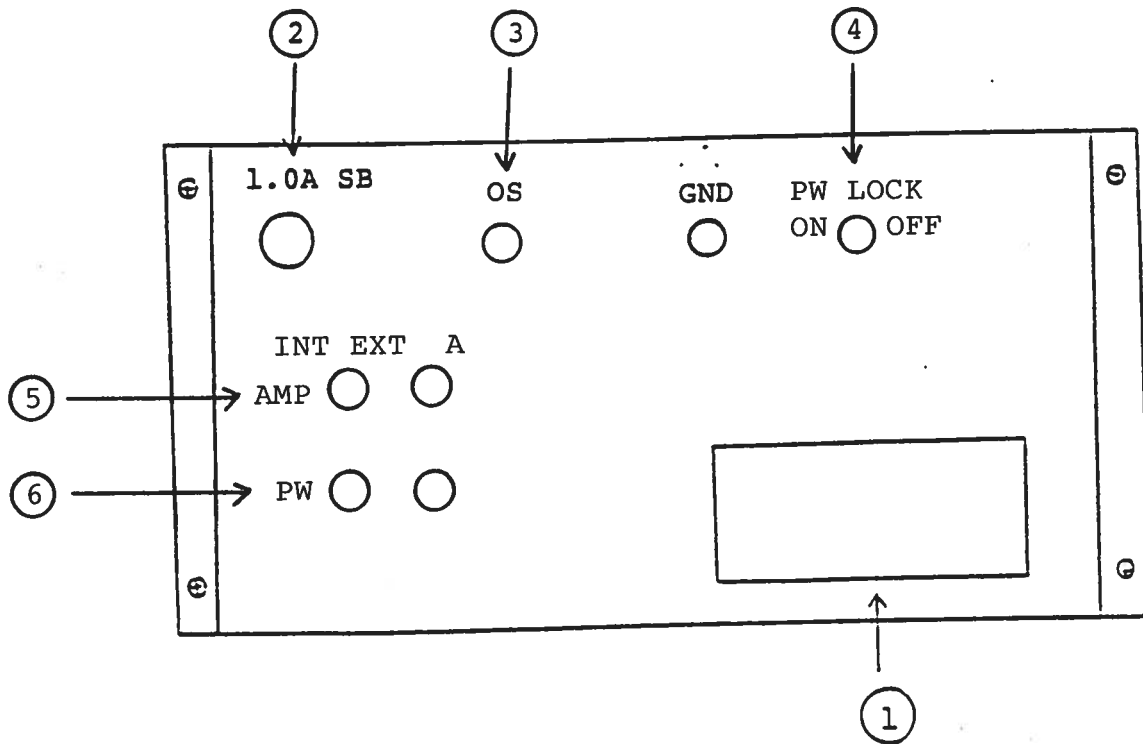



- (1) FUSED CONNECTOR, VOLTAGE SELECTOR. The detachable power cord is connected at this point. In addition, the removable cord is adjusted to select the desired input operating voltage. The unit also contains the main power fuse (0.5A SB).
- (2) 1.0A SB. Fuse which protects the output stage if the output duty cycle rating is exceeded.
- (3) DC Offset. To DC offset the output pulse at the output, connect a DC power supply set to the required DC offset value to the OS terminals ( $V_{MAX} \pm 50$  Volts,  $I_{MAX} \pm 100$  mA). (option).
- (4) PW LOCK. Due to the digital nature of the EW option, some pulse width jitter may be observed at certain settings of the PW pot. This jitter may be removed by setting the rear panel PW LOCK switch in the ON position. When in the ON position, the pulse becomes frozen and will not change (as the PW pot is adjusted) until the switch is placed in the OFF position.
- (5) AMP. To voltage control the output amplitude, set the rear panel switch in the EXT position and apply 0 to +10V to BNC connector A ( $R_{IN} \geq 10K$ ). (EA option).
- (6) PW. To voltage control the output pulse width, set the panel switch in the EXT position and apply 0 to +10V to BNC connector A ( $R_{IN} \geq 10K$ ). (EW option).

Fig. 4

SYSTEM BLOCK DIAGRAM

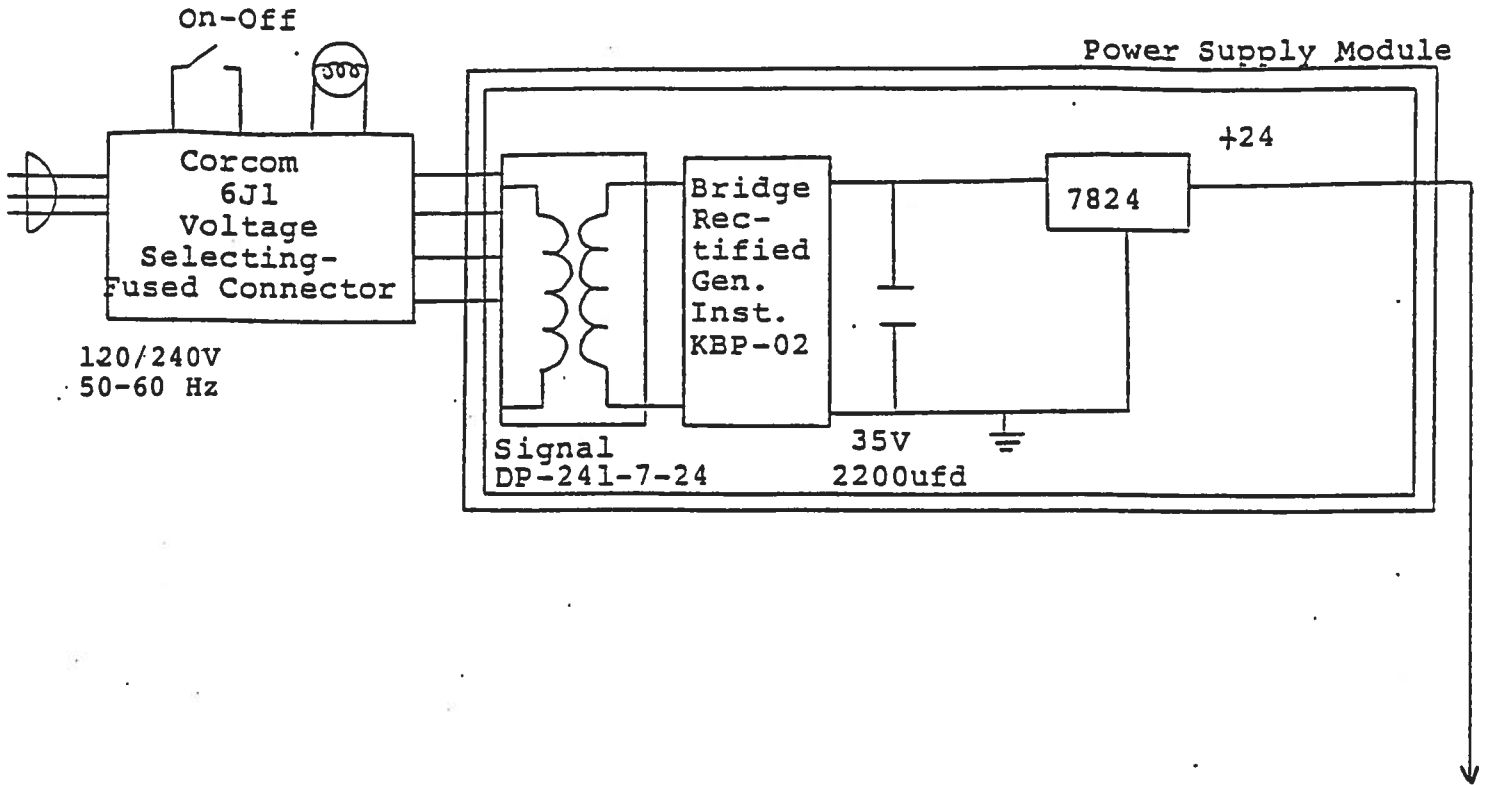

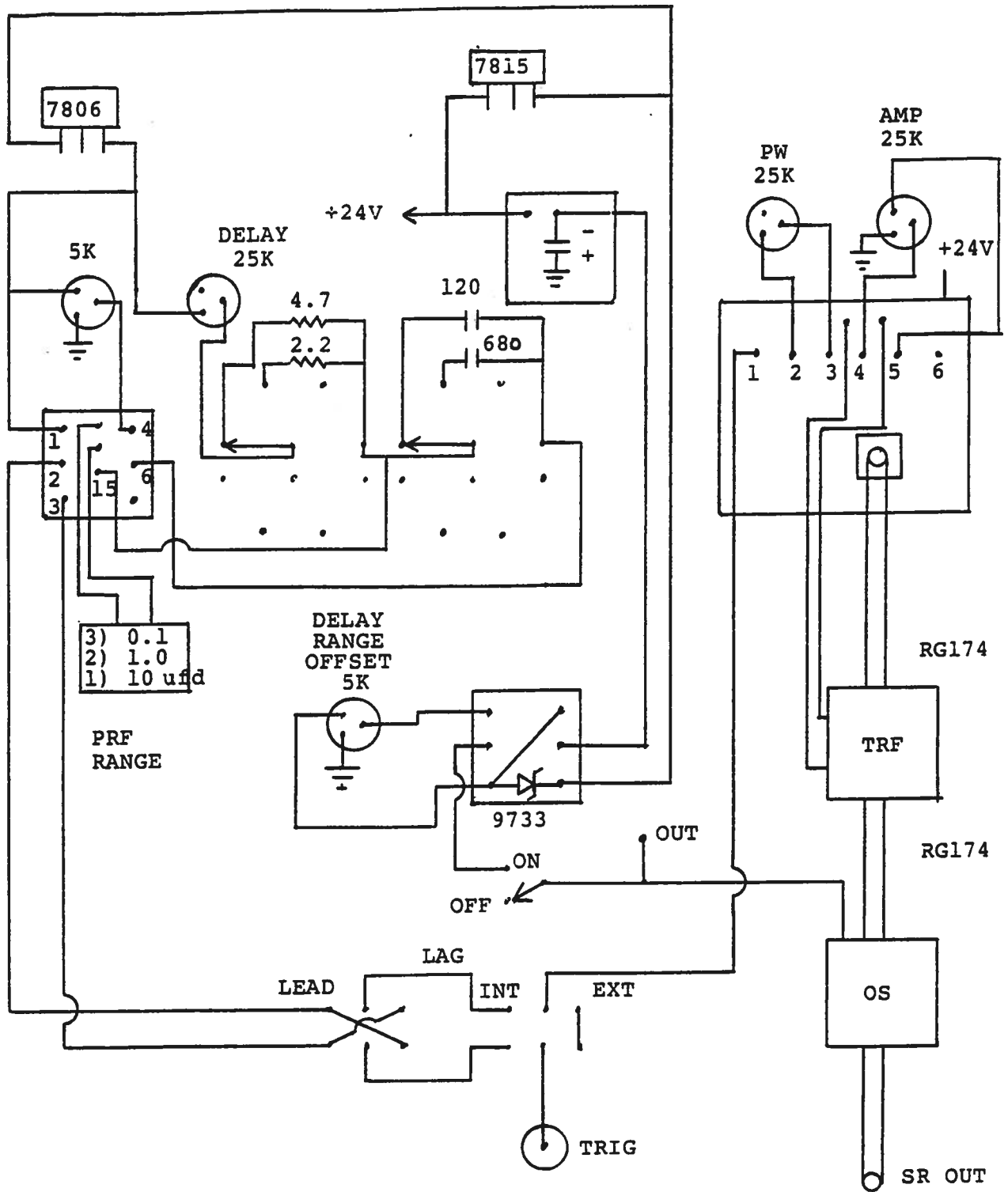

Fig. 5

AVR-EI-W-C-P-OT (GGB MOD)

## SYSTEM DESCRIPTION AND REPAIR PROCEDURE

The AVR-E2-C consists of the following basic modules:

- 1) AVR-E2-PG pulse generator module
- 2) AVR-E2-CL clock module
- 3) +24V power supply board
- 4) Overload module

The modules are interconnected as shown in Fig. 4.

The clock module controls the output PRF and the relative delay between the main output and the TRIG output. The PG pulse generator modules generate the output pulse. In the event of an instrument malfunction, it is most likely that the rear panel 1.0A SB fuse may have failed due to an output short circuit condition or to a high duty cycle condition. If the fuse is not blown, then the four Phillips screws on the back panel should be removed. The top cover may then be slid off and operation of the clock and power supply modules should be checked. The clock module is functioning properly if:

- a) 0.1 us TTL level outputs are observed at Pins 2 and 3.
- b) The PRF of the outputs can be varied over the range of 10 Hz to 10 kHz using the PRF controls.
- c) The relative delay between the Pin 2 and 3 outputs can be varied by at least 5 us by the DELAY controls.

The sealed clock module must be returned to Avtech for repair or replacement if the above conditions are not observed. The power supply board generates +24V DC to power the other modules. If the voltage is less than +24V, turn off the prime power and unsolder the lead from the 7824 regulator chip on the power supply board. Solder a 100 Ohm 5 Watt resistor to the 7824 output to ground and turn on the prime power. A voltage of +24 Volts should be read. If the voltage is less then the power supply board is defective and should be repaired or replaced.

Nov. 14/96

-EW

-EA

-OS

Disk: AVR-E

Name: EQPS.INS