



AVTECH ELECTROSYSTEMS LTD.

NANOSECOND WAVEFORM ELECTRONICS
SINCE 1975

P.O. BOX 265
OGDENSBURG, NY
U.S.A. 13669-0265
TEL: (315) 472-5270
FAX: (613) 226-2802

TEL: 1-800-265-6681
FAX: 1-800-561-1970
U.S.A. & CANADA

BOX 5120 STN. F
OTTAWA, ONTARIO
CANADA K2C 3H4
TEL: (613) 226-5772
FAX: (613) 226-2802

INSTRUCTIONS

MODEL AVR-E3-PS-PEC2A2 PULSE GENERATOR

S.N. :

WARRANTY

Avtech Electrosystems Ltd. warrants products of its manufacture to be free from defects in material and workmanship under conditions of normal use. If, within one year after delivery to the original owner, and after prepaid return by the original owner, this Avtech product is found to be defective, Avtech shall at its option repair or replace said defective item. This warranty does not apply to units which have been disassembled, modified or subjected to conditions exceeding the applicable specifications or ratings. This warranty is the extent of the obligation or liability assumed by Avtech with respect to this product and no other warranty or guarantee is either expressed or implied.

A)

GENERAL OPERATING PROCEDURE

Fig. 1

TEST ARRANGEMENT
(EXTERNAL LOAD)

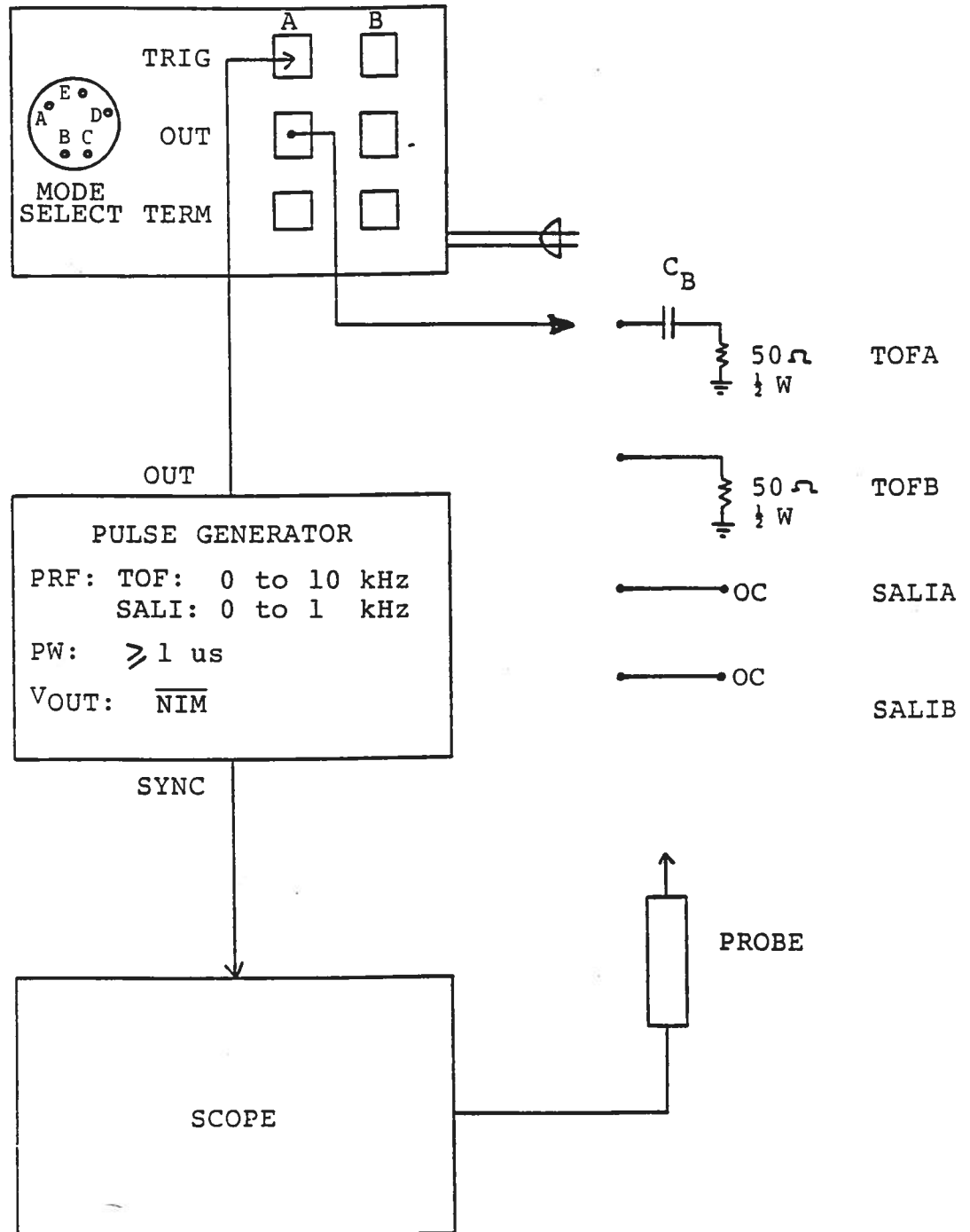
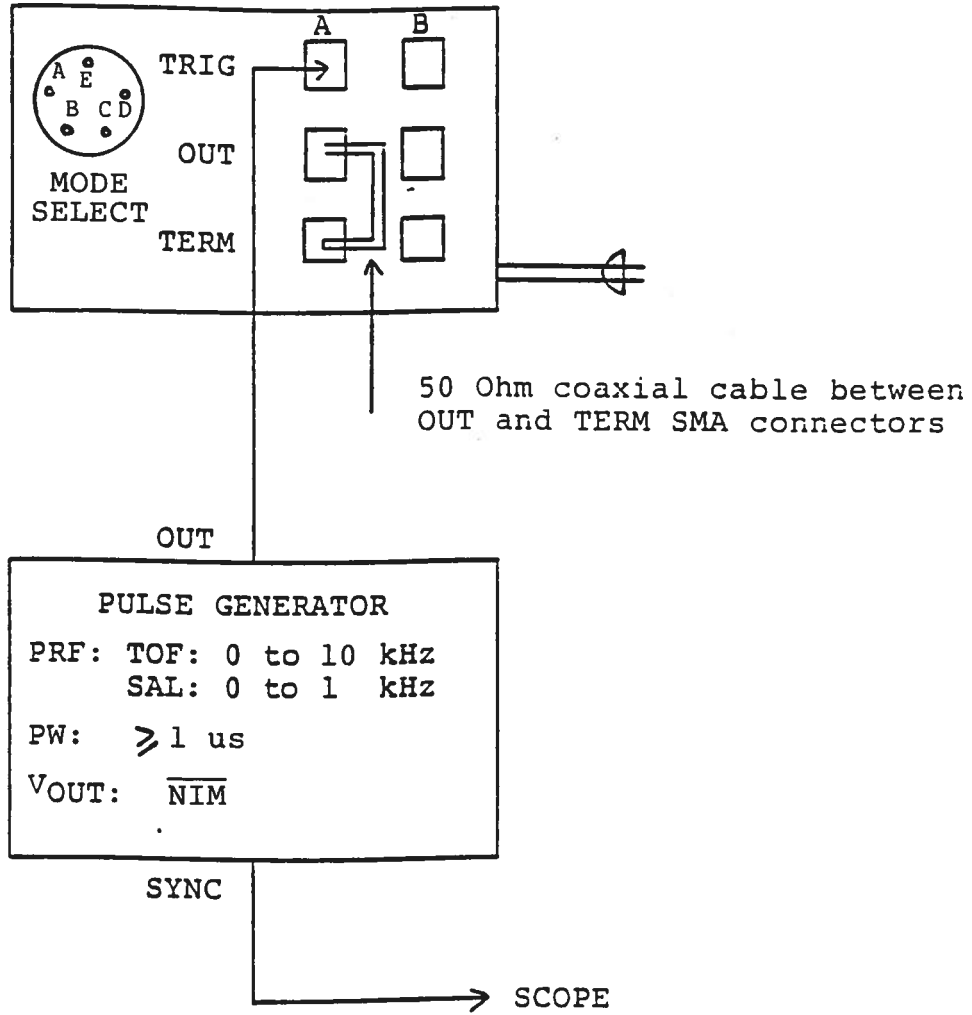

Fig. 2

TEST ARRANGEMENT
(INTERNAL LOAD)



GENERAL OPERATING INSTRUCTIONS

- 1) The arrangement shown in Fig. 1 may be used to check the basic waveforms using an oscilloscope.
- 2) The relationship between the logic levels applied to PINS A and C of the MODE SELECT connector and the outputs at the OUT terminal is described by the following truth table:

A	C	DC	TOF	SALI
0	0	1	0	0
0	1	0	0	1
1	0	0	1	0
1	1	0	0	0

- 3) With PIN A "LOW" and PIN C "LOW", the center conductor of the OUT SMA connectors are held at ground potential and so the unit does not provide any output pulses.
- 4) With PIN A "HIGH" and PIN C "LOW", the OUT SMA connectors provide the waveforms shown in Fig. 3. The one turn TAA, TAOS and TBA locking pots (see Fig. 4) are accessible in the interior of the instrument to provide the amplitude adjustments shown in Fig. 3. CAUTION: Potentials as high as 140 Volts DC are employed and exposed in the interior of the instrument (see Fig. 4).
- 5) With PIN A "LOW" and PIN C "HIGH", the OUT SMA connectors provide the waveforms shown in Fig. 5.
- 6) With PIN A "HIGH" and PIN C "HIGH" (i.e. "OFF" MODE), the A OUT is held at -120 Volts. The B OUT is held at ground by the 50 Ohm TERM B.

TOFA

TOFB

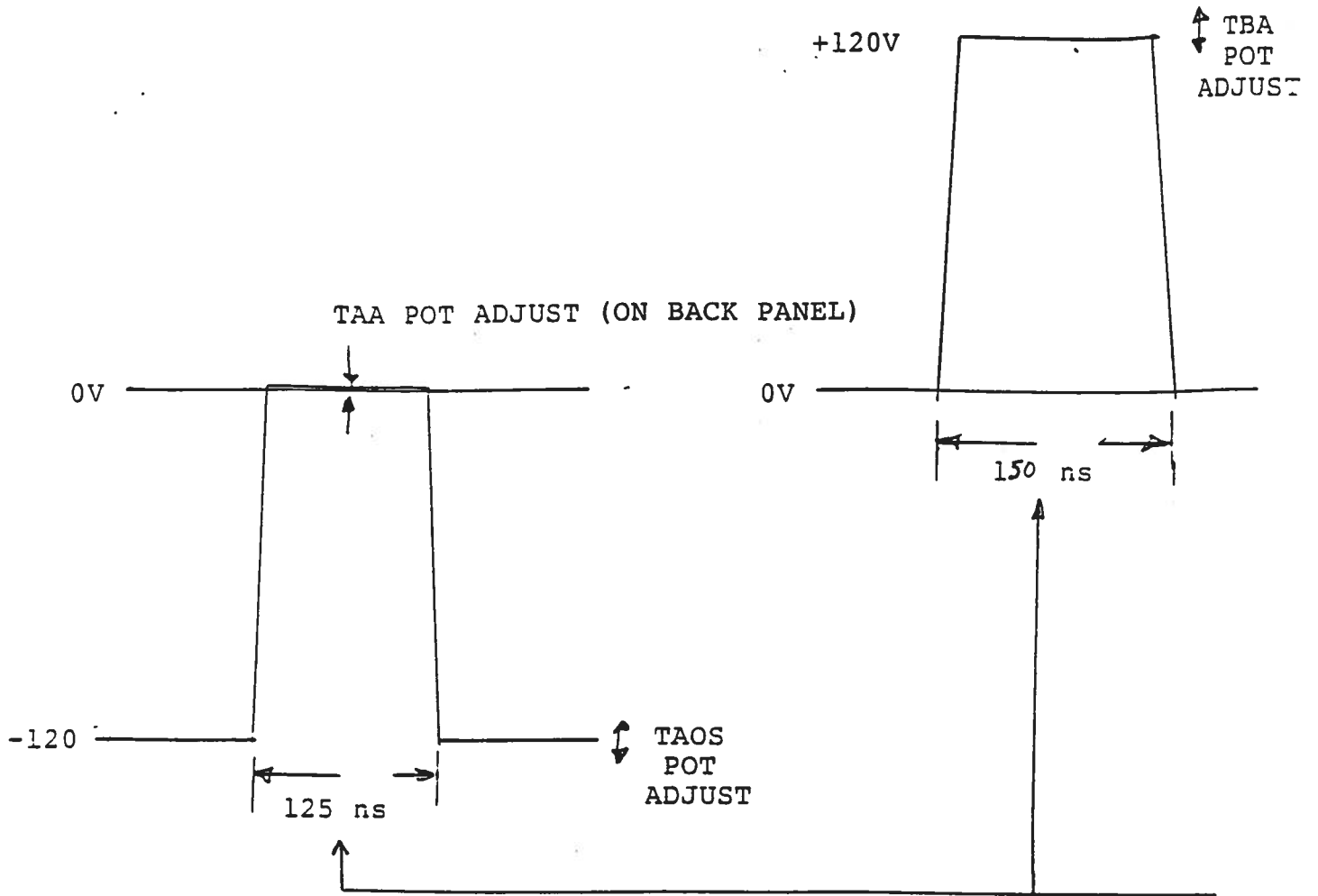

Fig. 3

TOF MODE OUTPUT WAVEFORMS

THE PW ARE
ADJUSTABLE USING THE
TWO LOCKING
POTS LOCATED ON
THE -P6 MODULES.
(± 50 NS)

SALI A

SALI B

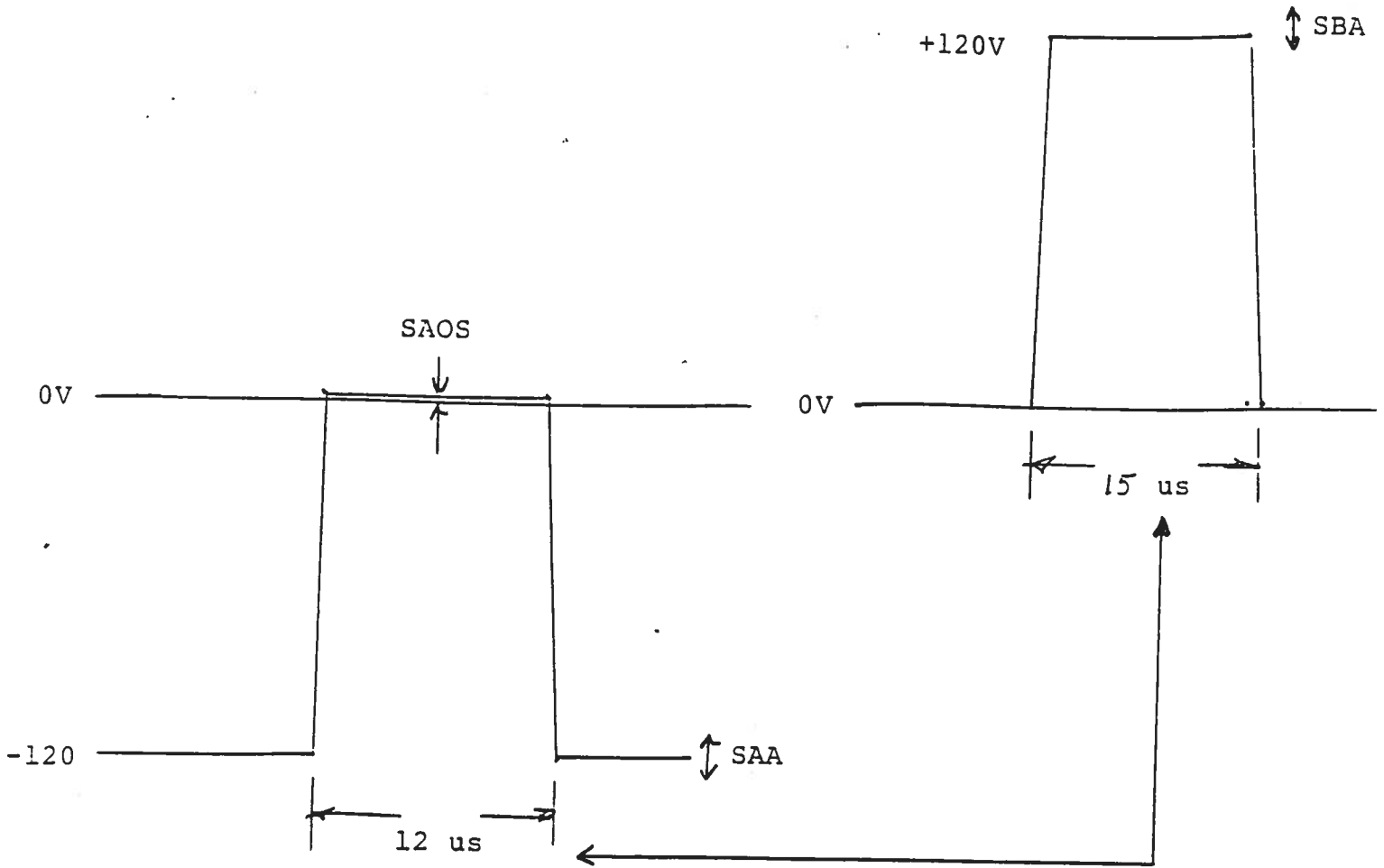
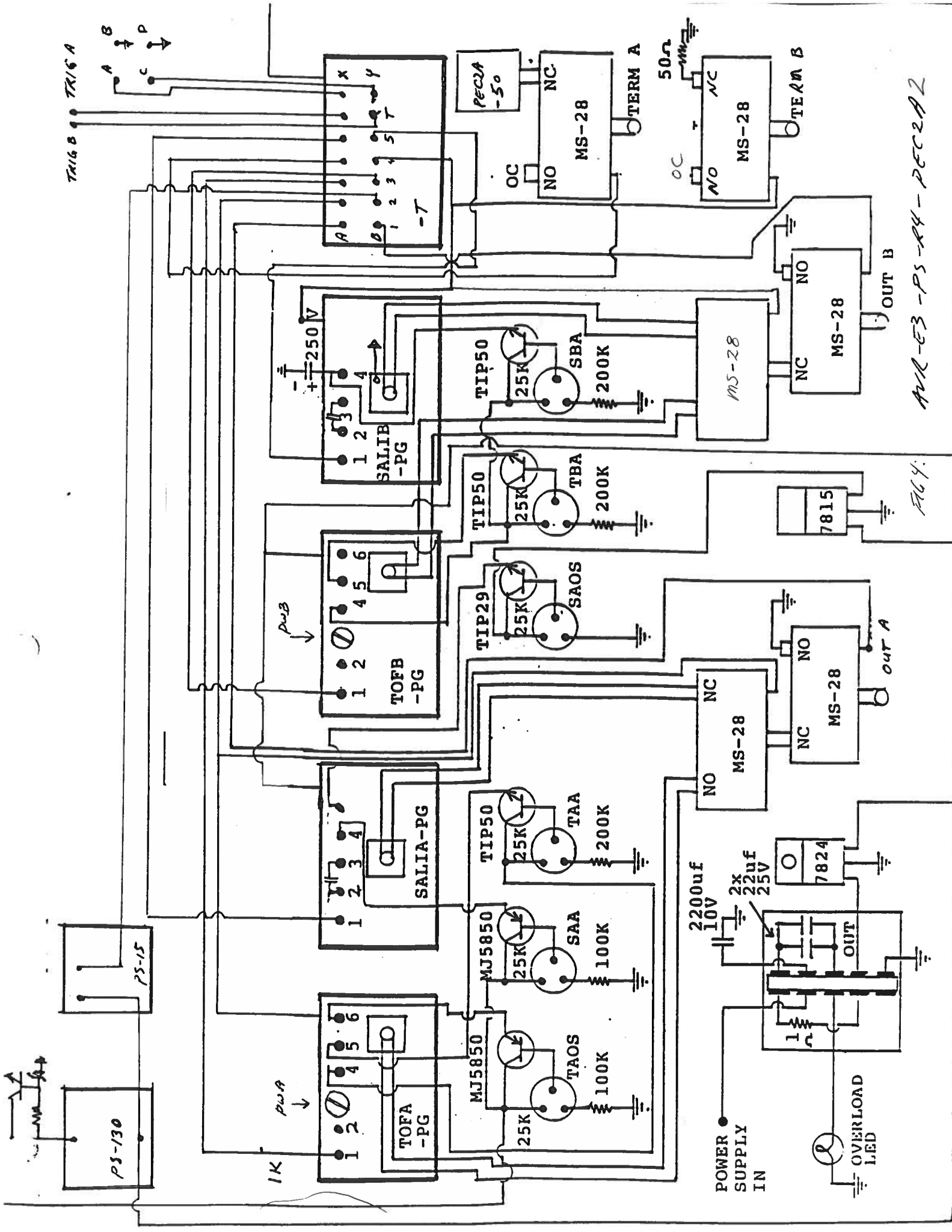

Fig. 5

SALI MODE OUTPUT WAVEFORMS

THE PW MAY
BE INCREASED BY
INCREASING THE C
BETWEEN PINS 2 & 3
ON THE SALI P6
MODULE.



AVR-E3-PS-R4-PECA2

FIG. 4

As with the TOF mode, the one turn SAA, SAOS or SBA locking pots (see Fig. 4) are provided in the interior of the instrument to achieve the amplitude adjustments shown in Fig. 5.

- 6) When driving a parallel plate load, a 50 Ohm coaxial transmission line (RG 58C or better) must be used to connect the SMA OUT terminal to the parallel plate function and onto the TERM SMA. The instrument automatically provides the correct termination internally.
- 7) The propagation delay for the TOF mode is 62 ns while the propagation delay for the SALI mode is 125 ns. Minor adjustments to the propagation delays can be implemented by extending (or shortening) the lead lengths to TERMINAL 1 of the 4 pulse generator modules. Changing the lead length by several inches will modify the propagation delay by about one nanosecond.

B)

FRONT PANEL CONTROLS

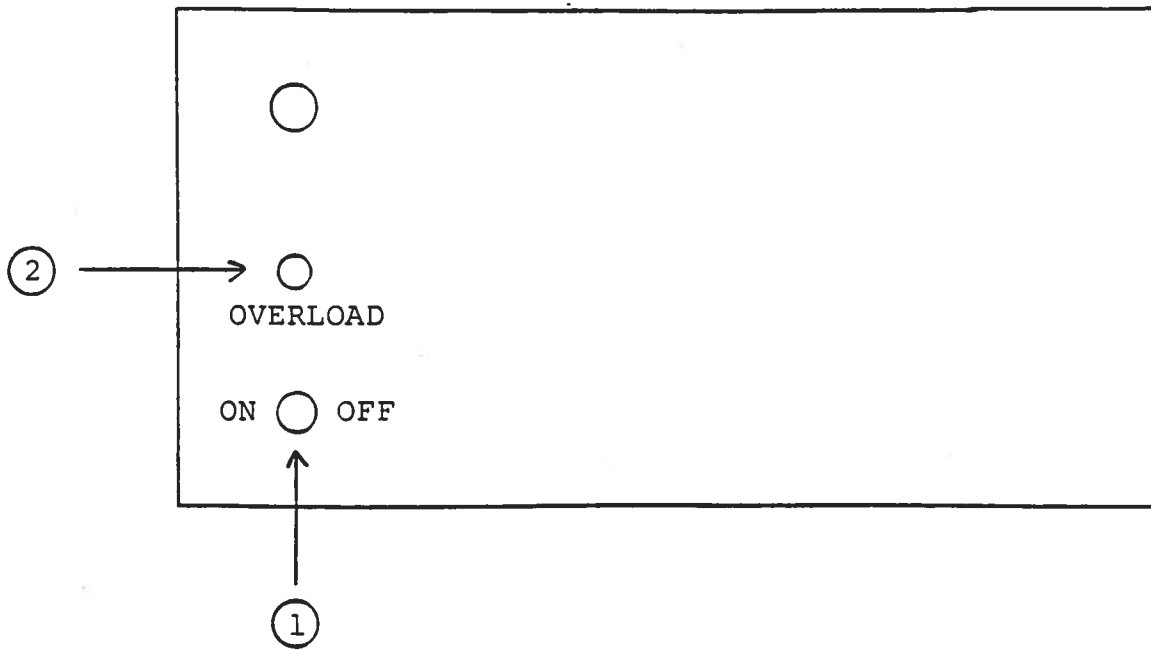

- (1) ON-OFF Switch. Applies prime power to all stages.
- (2) OVERLOAD INDICATOR. AVR units with a serial number higher than 5600 are protected by an automatic overload protective circuit which controls the front panel overload light. If the unit is overloaded (by operating at an exceedingly high duty cycle or by operating into a short circuit), the protective circuit will turn the output of the instrument OFF and turn the indicator light ON. The light will stay ON (i.e. output OFF) for about 5 seconds after which the instrument will attempt to turn ON (i.e. light OFF) for about 1 second. If the overload condition persists, the instrument will turn OFF again (i.e. light ON) for another 5 seconds. If the overload condition has been removed, the instrument will turn on and resume normal operation. Overload conditions may be removed by:

- 1) Reducing PRF (i.e. switch to a lower range)
- 2) Removing output load short circuit (if any)

C)

REAR PANEL CONTROLS

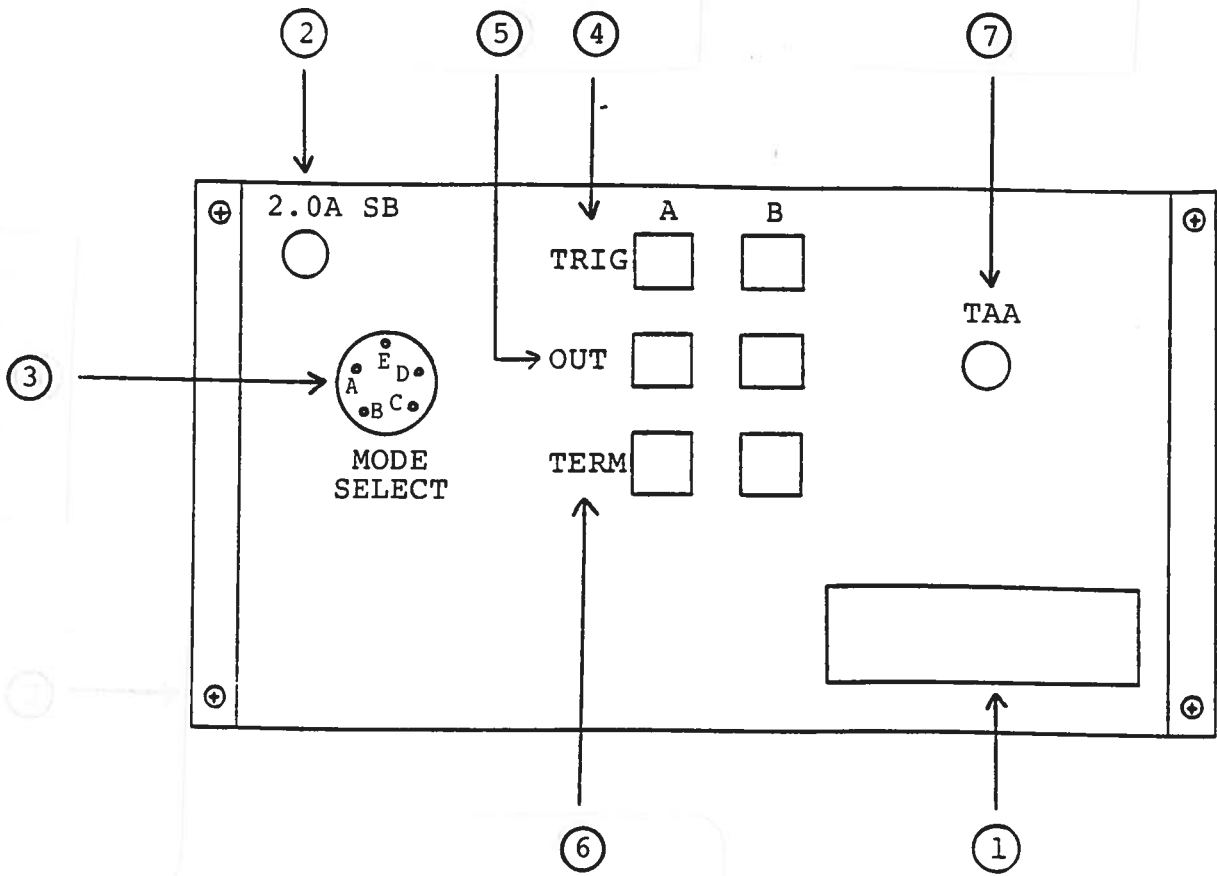

- (1) FUSED CONNECTOR, VOLTAGE SELECTOR. The detachable power cord is connected at this point. In addition, the removable cord is adjusted to select the desired input operating voltage. The unit also contains the main power fuse (0.5 A SB).
- (2) 2.0A SB. Fuse which protects the output stage if the output duty cycle rating is exceeded.
- (3) MODE SELECT. The relationship between the logic levels applied to PINS A and C of the MODE SELECT connector and the outputs at the OUT terminal is described by the following tenth table:

A	C	DC	TOF	SALI
0	0	1	0	0
0	1	0	0	1
1	0	0	1	0
1	1	0	0	0

- (4) TRIG. SMA connector to which 1 us (or wider) $\overline{\text{NIM}}$ pulse is applied. See paragraph 1, SECTION A. Input impedance is 50 Ohms.
- (5) OUT. SMA output connectors provide waveforms shown in Figs. 3 and 5, SECTION A.
- (6) TERM. SMA connection to internal terminations as per Fig. 1, SECTION A.
- (7) TAA. One turn locking pot to set TOFA during 125 ns interval at, or near, ground potential.

TOP COVER REMOVAL AND RACK MOUNTING

- 1) The interior of the instrument may be accessed by removing the four Phillips screws on the top panel. With the four screws removed, the top cover may be slid back (and off).
- 2) The -R5 rack mount kit may be installed after first removing the one Phillips screw on the side panel adjacent to the front handle.

D)

SYSTEM DESCRIPTION AND REPAIR PROCEDURE

The AVR unit consists of the following basic modules:

- a) PEC2A-TOFA-PG pulse generator module
- b) PEC2A-TOFB-PG pulse generator module
- c) PEC2A-SALIA-PG pulse generator module
- d) PEC2A-SALIB-PG pulse generator module
- e) PEC2A-T translation module
- f) PEC2A-50 termination
- g) PS-130 power supply module (-130V)
- h) PS-15 power supply module (-15V)
- i) MS-28 SPDT coaxial switches (6)
- j) +24 Volts DC power supply board

The -PG modules generate the basic pulses and the MS-28 coaxial switches are used to connect the module output to the SMA OUT connector. Similarly, the MS-28 coaxial switches are used to connect the appropriate internally contained termination to the TERM SMA connector.

In the event that the unit does not provide an output, check the rear panel 2.0A SB fuse and the 0.5A SB fuse in the line cord connector assembly. If the fuses are not blown then the SL5T transistors in each of the SALI -PG modules should be checked. The SL5 elements may be accessed by removing the 1.5 x 3.0 inch cover plates on the bottom side of the chassis and extracting the SL5T elements from their sockets by means of needle nose pliers. The SL5T element is an N channel VMOS transistor in a TO 220 package and its operation may be checked on a curve tracer. When re-installing the SL5T elements, take care to insure that the short lead is placed adjacent to the black dot on the bottom of the chassis. If the SL5T transistors are replaced and no output is obtained, the unit should be returned to AVTECH for repair. If no TOF outputs are obtained, the unit should be returned to AVTECH for repair.

For additional assistance:

Tel: (315) 472-5270
Fax: (613) 226-2802



AVTECH ELECTROSYSTEMS LTD.

NANOSECOND WAVEFORM ELECTRONICS
SINCE 1975

P.O. BOX 265
OGDENSBURG, NY
U.S.A. 13669-0265
TEL: (315) 472-5270
FAX: (613) 226-2802

TEL: 1-800-265-6681
FAX: 1-800-561-1970
U.S.A. & CANADA

X
BOX 5120 STN. F
OTTAWA, ONTARIO
CANADA K2C 3H4
TEL: (613) 226-5772
FAX: (613) 226-2802

October 18, 1993.

Kallie Wodash
Perkin-Elmer Corporation
6509 Flying Cloud Drive
Eden Prairie, MN 55344

Tel: 612-828-6100
Fax: 612-828-6441

Dear Kallie:

Following my recent discussions with Brian Brady, I am pleased to offer a price and delivery quotation for an AVR-E3-PS series blanking generator meeting the following specifications:

Model designation: AVR-E3-PS-PEC2A2.
Basic description: Functionally equivalent to Model AVR-E3-PS-PEC2A1 but operate with 6' cables (supplied) and OFF phase A OUT changed to -120 Volts.
PULSE A (START) PULSE B (STOP)
Amplitude: +120 Volts. +120 Volts.
Pulses from a base-line of -120 Volts to 0 V. Pulses from a base-line of 0 Volts to +120 Volts.
Pulse width: (at 10% rise point) DC mode: Center conductor of 50 Ohm line leading to plate grounded by means of a coaxial switch. Center conductor of 50 Ohm line leading to plate grounded by means of a coaxial switch.
TOF mode: 125 ns (internal pot adjustment). 150 ns (internal pot adjustment).
SALI mode: 12 us (internal adjustment). 15 us (internal adjustment).

		PULSE A (START)	PULSE B (STOP)
Termination required: (terminations are contained in main chassis and are accessed via two rear panel SMA connectors. Correct ter- mination is selected by rear panel MODE SELECT INPUTS.	TOF mode:	50 Ohm with 120 Volt DC blocking capacitor.	50 Ohm.
	SALI mode:	Open circuit.	Open circuit.

• Rise time (fall time):

	TOF mode:	1 ns (1 ns).	1 ns (1 ns).
	SALI mode:	10 ns (100 ns).	20 ns (100 ns).
PRF:	TOF mode:	0 to 10 kHz.	0 to 10 kHz.
	SALI mode:	0 to 1 kHz.	0 to 1 kHz.

Input
trigger:

Triggers on the rising edge of a NIM signal (when it goes from -.8 Volts to 0 Volts). Trigger signal will be brought low for at least 5 microseconds before the trigger point. Trigger signals will then remain high (at 0 Volts) for the rest of the cycle until just before the next trigger point.

Triggers on the rising edge of a NIM signal (when it goes from -.8 Volts to 0 Volts). Trigger signal will be brought low for at least 5 microseconds before the trigger point. Trigger signals will then remain high (at 0 Volts) for the rest of the cycle until just before the next trigger point.

		PULSE A (START)	PULSE B (STOP)
Jitter:		$\leq \pm 100$ ps.	$\leq \pm 100$ ps.
Propagation delay:		100 ns.	100 ns.
Droop:	TOF mode:	≤ 1 Volt after 10 ns.	≤ 1 Volt after 10 ns.
	SALI mode:	≤ 200 mV after 40 ns.	≤ 200 mV after 40 ns.
Initial ringing:	TOF mode:	≤ 2 Volts peak to peak for first 10 ns.	≤ 2 Volts peak to peak for first 10 ns.
	SALI mode:	≤ 1 Volt peak to peak from 20 to 40 ns.	≤ 1 Volt peak to peak from 20 to 40 ns.

Mode
selection:

Outputs 0 and 1 on the Model 257 computer interface board in the SCAN ADD-ON 486 PC will select one of three operating modes (or OFF) for the Blanking Pulser.

The Blanking Pulser operated modes will be decoded and selected as follows:

11, both lines high (or open circuit) = A output at
-120 VDC and
B output at
0 Volts

10, 0 high & 1 low = TOF mode w/ 125 ns wide pulses at
0 to 10 kHz max rep rate

01, 0 low & 1 high = SALI mode w/ 12 us (or 15 us)
wide pulses at 0 to 1 kHz max rep rate

00, both lines low = DC outputs steady ON

The handshake output lines from the 257 board are driven by 74LS794 latching TTL gates with totem pole outputs. Their output levels and drive are spec'd to:

Sink: 24ma at .5 Volts on a LOW (logic 0)
Source: 2.4ma at 2.4 Volts on a HIGH (logic 1)

The inputs on the Blanking Pulser will be LS style gates with pull-ups and clamping diodes so that an open circuit will be treated the same as a HIGH (logical 1). The 257 interface board must continuously pull one or both Blanking Pulser input lines low to get any output. It may take between 10 and 100 millisecc's for the pulser to turn ON or OFF or change modes.

The computer control input to the Blanking Pulser will be a standard MS3102-16S-8S female, box mount style connector with the following pin-outs:

Signal	MS-3102	Handshake Connector
Line 0 - signal	A	J2, Pin 1
" ground	B	J2, Pin 2
Line 1 - signal	C	J4, Pin 1
" ground	D	J4, Pin 2

Chassis size: 3.9" x 17" x 14.8". Includes the R5 rack mount kit for 19" installation. This chassis is our new heavy duty style as per Model AV-1010-C.

Output connectors: SMA (two).

Input connectors: SMA (four: two triggers and two terminations).

Mode select connectors: MS3102-16S-8S (female).

Prime power: 120/240 Volts, 50-60 Hz.

Price: Quantity of 1:
 \$5,698.00 US each, FOB destination.
 Price includes mainframe, internally contained load terminations and four six foot output cables (80 ~~ft~~ ~~semi-rigid~~ (R653C))

Quantities of 2 to 10:
 For subsequent individual orders, deduct N-1% where N is the total number of orders placed since August 1, 1993 (eg. for the second unit deduct 1%, for the third unit deduct 2%). If placing orders for multiple units on a single P.O., deduct an additional M% (eg. if units 4 and 5 ordered together, deduct a total of 3% + 2% from unit 4 and 4% + 2% for unit 5). Maximum discount per unit limited to 10% and this pricing structure expires on August 1, 1994.

Delivery: 45 days ARO.

Thank you for your continuing interest in our products. Please call me (1-800-265-6681) if you require any additional information or modifications to the above quotation.

Yours truly,

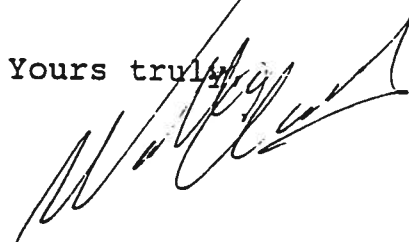
A handwritten signature in black ink, appearing to read 'W. Chudobiak', written over the 'Yours truly,' text.

Dr. Walter Chudobiak
Chief Engineer

WC:pr
Encl.

AVTECH AVR-E3-PS-REC2A2

2007

FRONT PANEL

AVTECH

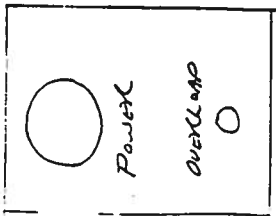

AVR-E3-PS-REC2A2

FUSE



20A x3



REAR PANEL

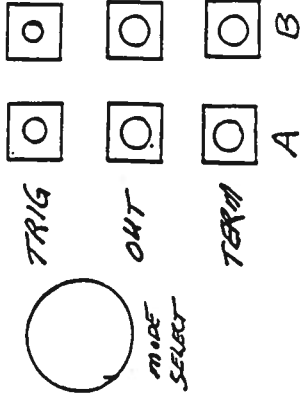
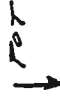

MS 3102
CONNECTOR



SMA
CONNECTOR

Dec. 22/93 #1