



AVTECH ELECTROSYSTEMS LTD.
NANOSECOND WAVEFORM ELECTRONICS

□ P.O. BOX 265
OGDENSBURG, NY
U.S.A. 13669-0265
TEL: (315) 472-5270
FAX: (613) 226-2802

☒ BOX 5120 STN. F
OTTAWA, ONTARIO
CANADA K2C 3H4
TEL: (613) 226-5772
FAX: (613) 226-2802

INSTRUCTIONS

MODEL AVR-E3-PS-R4-PEC2 PULSE GENERATOR

S.N. :

WARRANTY

Avtech Electrosystems Ltd. warrants products of its manufacture to be free from defects in material and workmanship under conditions of normal use. If, within one year after delivery to the original owner, and after prepaid return by the original owner, this Avtech product is found to be defective, Avtech shall at its option repair or replace said defective item. This warranty does not apply to units which have been disassembled, modified or subjected to conditions exceeding the applicable specifications or ratings. This warranty is the extent of the obligation or liability assumed by Avtech with respect to this product and no other warranty or guarantee is either expressed or implied.

A)

GENERAL OPERATING PROCEDURE

Fig. 1

TEST ARRANGEMENT
(EXTERNAL LOAD)

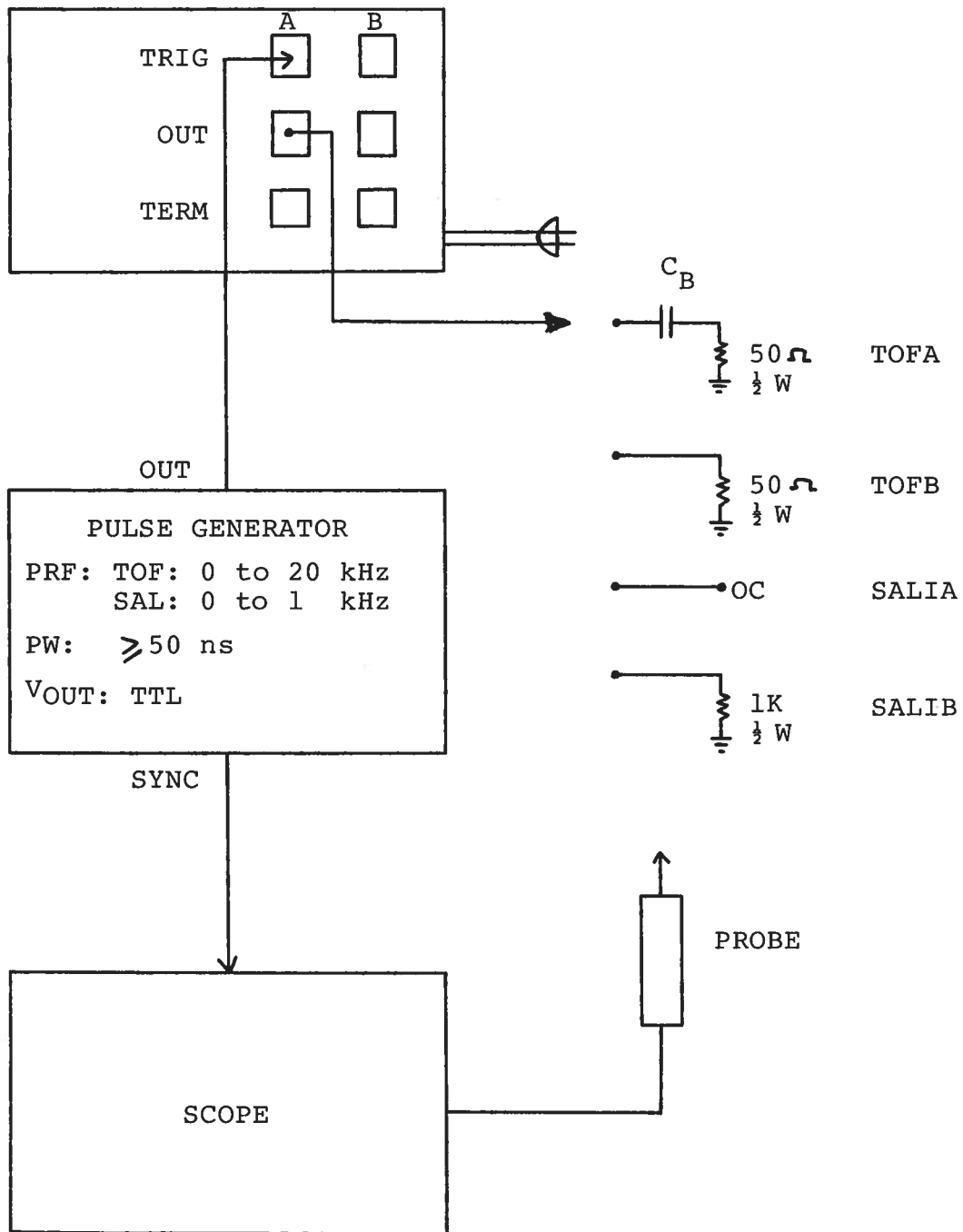
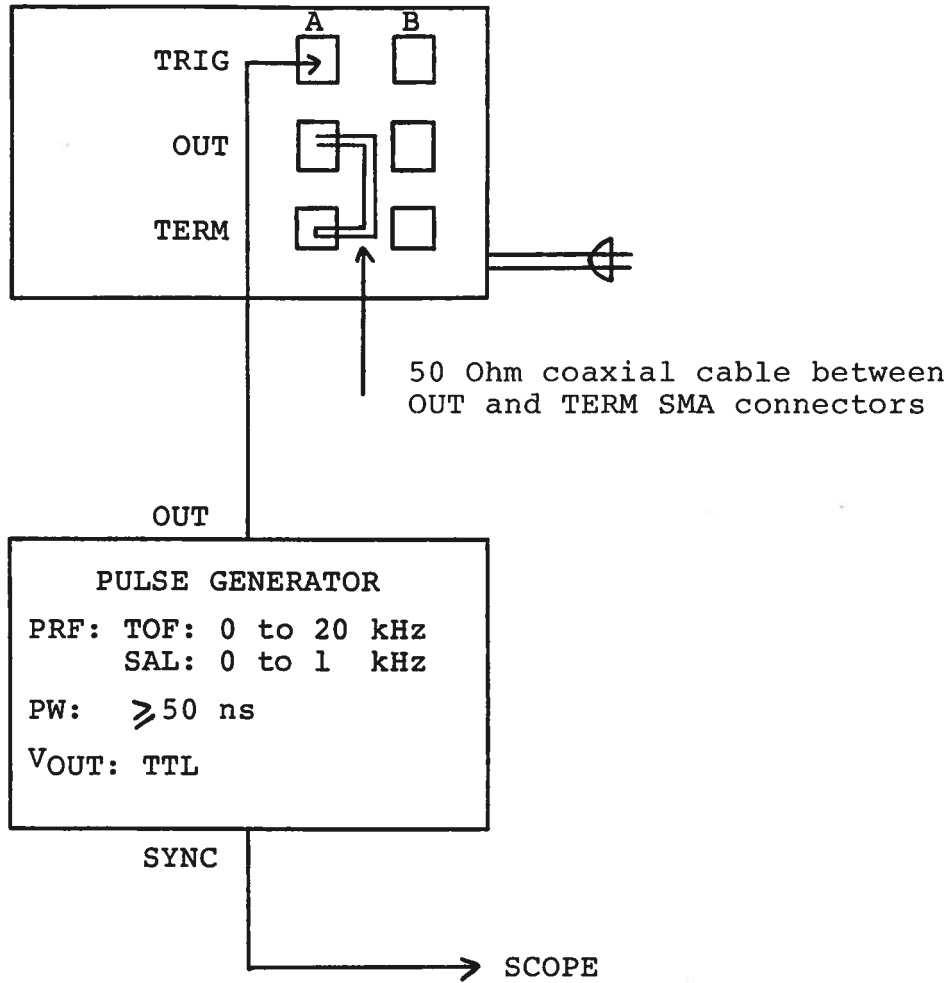

Fig. 2

TEST ARRANGEMENT
(INTERNAL LOAD)



GENERAL OPERATING INSTRUCTIONS

- 1) The arrangement shown in Fig. 1 may be used to check the basic waveforms using an oscilloscope. Note that at the time of shipping, the unit is wired to trigger from TTL input pulses (50 Ohm input impedance). To trigger from NIM or $\overline{\text{NIM}}$ inputs it is necessary to change the solder connections to the -PS module as shown in Fig. 3 (see Fig. 5 also).

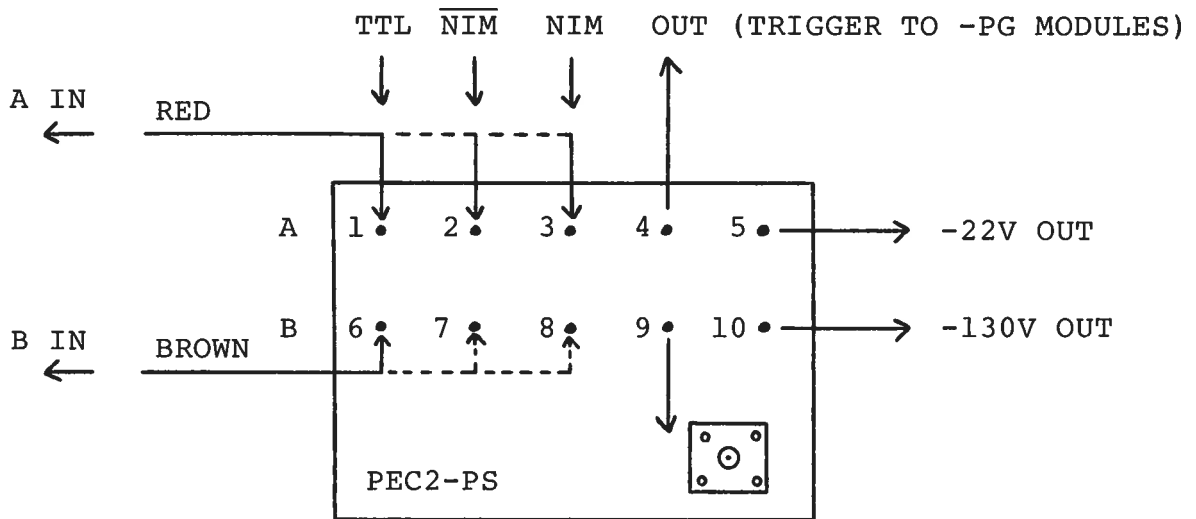

Fig. 3: PEC2-PS MODULE CONNECTIONS FOR TTL, $\overline{\text{NIM}}$ AND NIM TRIGGERING

- 2) To access the PEC2-PS module, remove the 4 Phillips screws on the back panel. This will allow the top cover to be slid back thereby exposing the interior of the instrument. Turn off the prime power before removing the top cover (and before soldering the connections).
- 3) With the front panel selector switch in the DC position the center conductor of the OUT SMA connectors are held at ground potential and so the unit does not provide any output pulses. The rear panel DC banana connector is at a potential of +5 Volts (to $R_L > 1K$).
- 4) With the front panel selector switch in the TOF position the OUT SMA connectors provide the waveforms shown in Fig. 4. The one turn TAA, TAOS and TBA locking pots (see Fig. 5) are accessible in the interior of the instrument to provide the amplitude adjustments shown in Fig. 4. CAUTION: Potentials as high as 140 Volts DC are employed and exposed in the interior of the instrument (see Fig. 5). The rear panel TOF banana connector is at a potential of +5 Volts (to $R_L > 1K$) when the instrument is operating in the TOF mode.
- 5) With the front panel selector switch in the SALI position, the OUT SMA connectors provide the waveforms shown in Fig. 6.

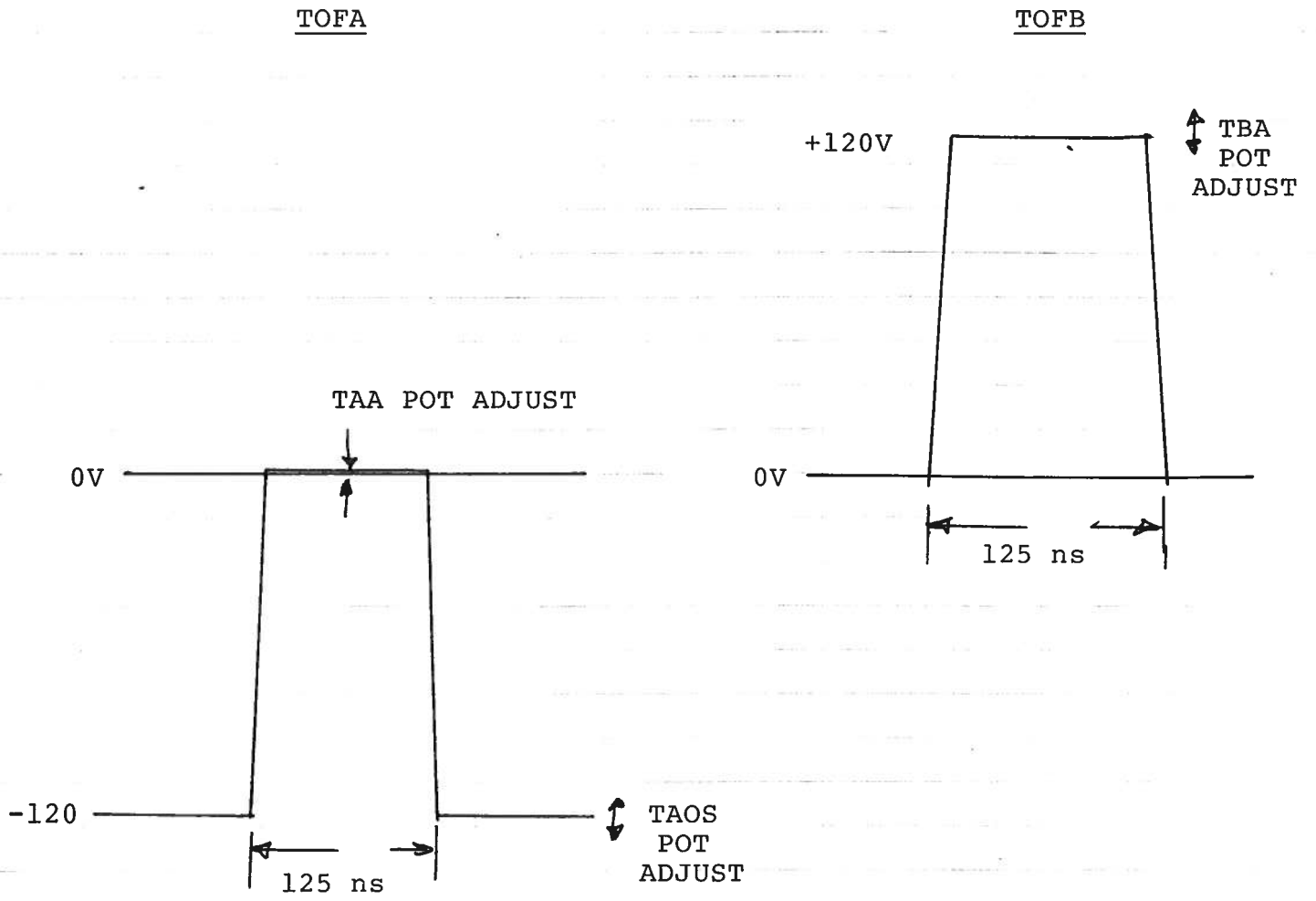

Fig. 4

TOF MODE OUTPUT WAVEFORMS

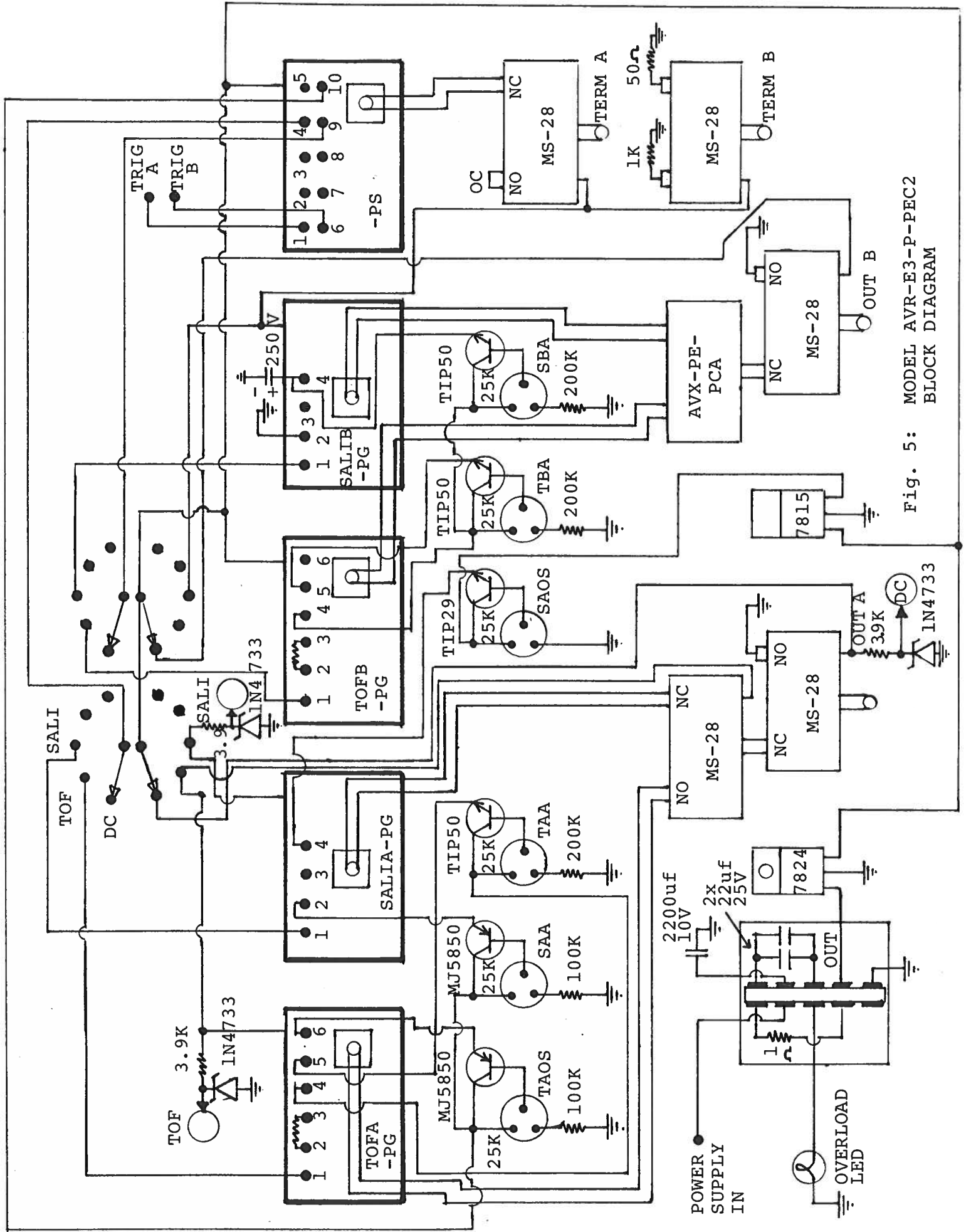

Fig. 5: MODEL AVR-E3-P-PEC2
BLOCK DIAGRAM

SALI A

SALI B

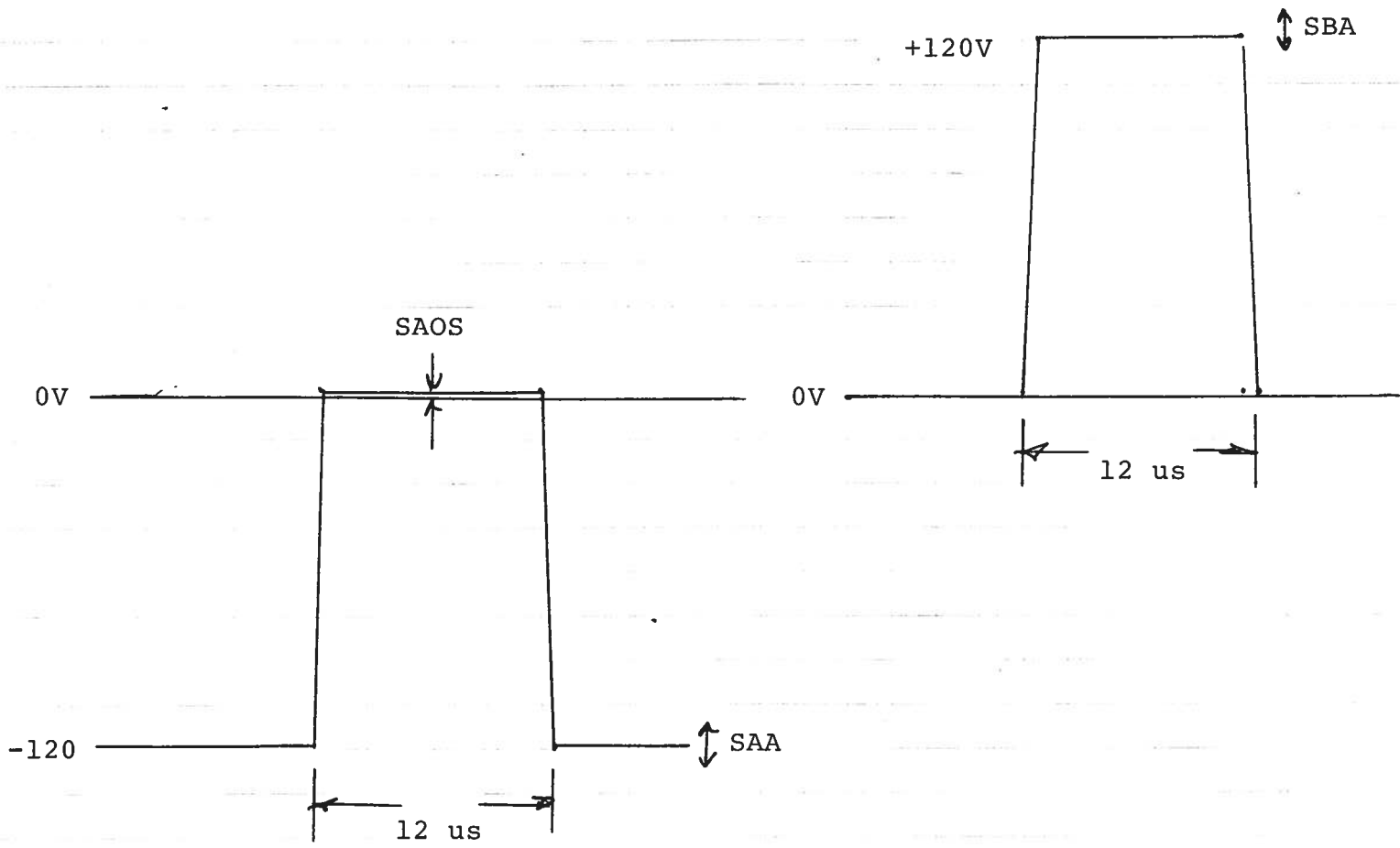

Fig. 6

SALI MODE OUTPUT WAVEFORMS

As with the TOF mode, the one turn SAA, SAOS or SBA locking pots (see Fig. 5) are provided in the interior of the instrument to achieve the amplitude adjustments shown in Fig. 6. The rear panel SALI banana connector provides +5 Volts (to $R_L > 1K$) when the instrument is operating in the SALI mode.

- 6) When driving a parallel plate load, a 50 Ohm coaxial transmission line (RG 174 or better) must be used to connect the SMA OUT terminal to the parallel plate function and onto the TERM SMA. The instrument automatically provides the correct termination internally.
- 7) The propagation delay for the TOF mode is 62 ns while the propagation delay for the SALI mode is 125 ns. Minor adjustments to the propagation delays can be implemented by extending (or shortening) the lead lengths to TERMINAL 1 of the 4 pulse generator modules. Changing the lead length by several inches will modify the propagation delay by about one nanosecond.

B)

FRONT PANEL CONTROLS

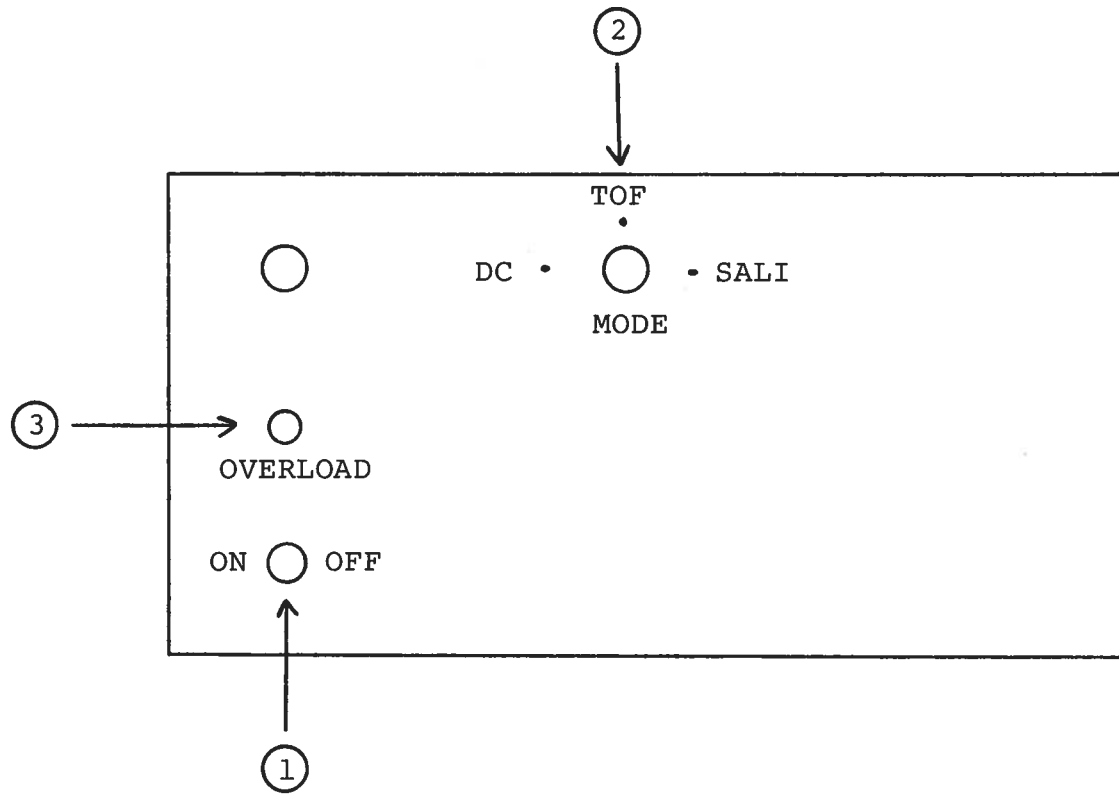

- (1) ON-OFF Switch. Applies prime power to all stages.
- (2) MODE Switch. 3 position switch controls nature of output signal at rear panel SMA OUT connector. In the DC position, the center conductor of the rear panel SMA OUT connector is fixed at ground potential by an internally controlled coaxial shorting switch. In the TDF position the OUT SMA connectors provide 125 ns wide 120 Volt pulses of the type shown in Fig. 4. When in the SALI position the rear panel outputs provide the 12 us wide 120 Volt outputs shown in Fig. 6.
- (3) OVERLOAD INDICATOR. AVR units with a serial number higher than 5600 are protected by an automatic overload protective circuit which controls the front panel overload light. If the unit is overloaded (by operating at an exceedingly high duty cycle or by operating into a short circuit), the protective circuit will turn the output of the instrument OFF and turn the indicator light ON. The light will stay ON (i.e. output OFF) for about 5 seconds after which the instrument will attempt to turn ON (i.e. light OFF) for about 1 second. If the overload condition persists, the instrument will turn OFF again (i.e. light ON) for another 5 seconds. If the overload condition has been removed, the instrument will turn on and resume normal operation. Overload conditions may be removed by:
 - 1) Reducing PRF (i.e. switch to a lower range)
 - 2) Removing output load short circuit (if any)

c)

REAR PANEL CONTROLS

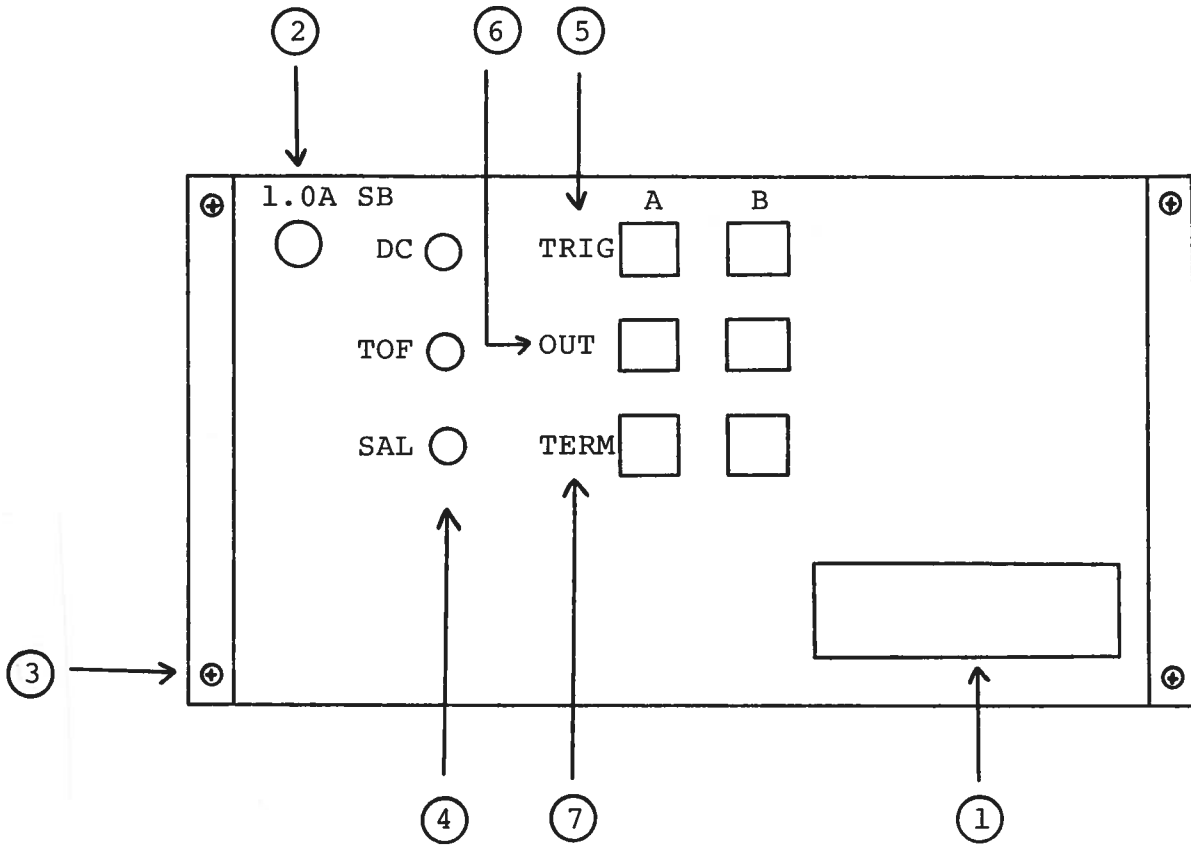

- (1) FUSED CONNECTOR, VOLTAGE SELECTOR. The detachable power cord is connected at this point. In addition, the removable cord is adjusted to select the desired input operating voltage. The unit also contains the main power fuse (0.5 A SB).
- (2) 1.0A SB. Fuse which protects the output stage if the output duty cycle rating is exceeded.
- (3) PHILLIPS SCREWS. Remove 4 rear panel PHILLIPS screws to allow the removal of the top cover (slides back).
- (4) STATUS INDICATOR. Banana connectors provide +5 Volts (to $R_L > 1K$) depending on front panel MODE switch position.
- (5) TRIG. SMA connector to which 50 ns (or wider) TTL (or NIM or NIM) pulse is applied. See paragraph 1, SECTION A. Input impedance is 50 Ohms.
- (6) OUT. SMA output connectors provide waveforms shown in Figs. 4 and 6, SECTION A.
- (7) TERM. SMA connection to internal termination as per Fig. 1, SECTION A.

D)

SYSTEM DESCRIPTION AND REPAIR PROCEDURE

The AVR unit consists of the following basic modules:

- a) PEC2-TOFA-PG pulse generator module
- b) PEC2-TOFB-PG pulse generator module
- c) PEC2-SALIA-PG pulse generator module
- d) PEC2-SALIB-PG pulse generator module
- e) PEC2-PS power supply and translation module
- f) AVX-PE-PCA power combiner module (diode or gate)
- g) MS-28 SPDT coaxial switches (5)
- h) +24 Volts DC power supply board

The -PG modules generate the basic pulses and the MS-28 coaxial switches (and the AVX-PE-PCA combiner module) are used to connect the module output to the SMA OUT connector. Similarly, the MS-28 coaxial switches are used to connect the appropriate internally contained termination to the TERM SMA connector.

In the event that the unit does not provide an output, check the rear panel 1.0A SB fuse and the 0.5A SB fuse in the line cord connector assembly. If the fuses are not blown then the SL5T transistors in each of the 4 -PG modules should be checked. The SL5 elements may be accessed by removing the 1.5 x 3.0 inch cover plates on the bottom side of the chassis and extracting the SL5T elements from their sockets by means of needle nose pliers. The SL5T element is an N channel VMOS transistor in a TO 220 package and its operation may be checked on a curve tracer. When re-installing the SL5T elements, take care to insure that the short lead is placed adjacent to the black dot on the bottom of the chassis. If the SL5T transistors are replaced and no output is obtained, the unit should be returned to AVTECH for repair.

For additional assistance:

Tel: (315) 472-5270
Fax: (613) 226-2802

AVTECH ELECTROSYSTEMS LTD.

NANOSECOND WAVEFORM ELECTRONICS
ENGINEERING - MANUFACTURING

□ P.O. BOX 265
OGDENSBURG
NEW YORK
13669
(315) 472-5270

□ BOX 5120, STN. "F"
OTTAWA, ONTARIO
CANADA K2C 3H4
TEL: (613) 226-5772
FAX: (613) 226-2802

January 6, 1992.

Brian Brady
Perkin Elmer Corporation
6509 Flying Cloud Drive
Eden Prairie, MN 55344

Tel: 612-828-6100
Fax: 612-828-6235

Dear Brian:

Following my fax of December 23 and our telephone conversation of January 6, I am pleased to offer a revised price and delivery quotation for a special purpose two channel blanking generator meeting the following specifications:

Model
designation:

AVR-E3-PS-R4-PEC2.

PULSE A
(START)

PULSE B
(STOP)

Amplitude:

+120 volts.
Pulses from a base-
line of -120 volts
to 0 V.

+120 volts.
Pulses from a base-
line of 0 volts to
+120 volts.

Pulse width:
(one three
position
selector
switch.
Pulse width
at 10% rise
point)

DC mode:

Center conductor
of 50 ohm line
leading to plate
grounded by means
of a coaxial
switch.

Center conductor of
50 ohm line leading
to plate grounded
by means of a
coaxial switch.

TOF mode:

125 ns (fixed).

125 ns (fixed).

SALI mode:

12 us (fixed).

12 us (fixed).

| | | PULSE A (START) | PULSE B (STOP) |
|--|------------|--|--|
| Termination required: (terminations are contained in main chassis and are accessed via two rear panel SMA connectors. Correct ter- mination is selected by front panel selector switch) | TOF mode: | 50 ohm with 120 volt DC blocking capacitor. | 50 ohm. |
| | SALI mode: | Open circuit. | Open circuit. |
| Rise time (fall time): | | | |
| | TOF mode: | 1 ns (1 ns). | 1 ns (1 ns). |
| | SALI mode: | 10 ns (100 ns). | 20 ns (100 ns). |
| PRF: | TOF mode: | 0 to 20 KHz. | 0 to 20 KHz. |
| | SALI mode: | 0 to 1 KHz. | 0 to 1 KHz. |
| Input trigger: | TOF mode: | NIM, $\overline{\text{NIM}}$ or 50 ohm TTL. PW \geq 50 ns. Triggers on leading edge. Resolder an internally ac- cessible jumper wire to change trigger modes. | NIM, $\overline{\text{NIM}}$ or 50 ohm TTL. PW \geq 50 ns. Triggers on leading edge. Resolder an internally ac- cessible jumper wire to change trigger modes. |
| | SALI mode: | NIM, $\overline{\text{NIM}}$ or 50 ohm TTL. PW \geq 50 ns. Triggers on leading edge. Resolder an internally ac- cessible jumper wire to change trigger modes. | NIM, $\overline{\text{NIM}}$ or 50 ohm TTL. PW \geq 50 ns. Triggers on leading edge. Resolder an internally ac- cessible jumper wire to change trigger modes. |

| | | PULSE A (START) | PULSE B (STOP) |
|-----------------------------------|---|--|--|
| Jitter: | | \leq <u>+100</u> ps. | \leq <u>+100</u> ps. |
| Propagation delay: | | 100 ns. | 100 ns. |
| Droop: | TOF mode: | \leq 1 volt after 10 ns. | \leq 1 volt after 10 ns. |
| | SALI mode: | \leq 200 mV after 40 ns. | \leq 200 mV after 40 ns. |
| Initial ringing: | TOF mode: | \leq 2 volts peak to peak for first 10 ns. | \leq 2 volts peak to peak for first 10 ns. |
| | SALI mode: | \leq 1 volt peak to peak from 20 to 40 ns. | \leq 1 volt peak to peak from 20 to 40 ns. |
| Chassis size: | 4" x 16" x 12". Includes R4 rack mount kit for 19" installation. | | |
| Output connectors: | SMA (two). | | |
| Input connectors: | SMA (four: two triggers and two terminations). | | |
| Selector switch status indicator: | Three rear panel female banana connectors (one each for DC, TOF and SALI modes). Connector potential (to R > 1 K) is +5 volts when mode activated (0 volts when not activated). | | |
| Prime power: | 120/240 volts, 50-60 Hz. | | |
| Price: | \$5,940.00 US each, FOB destination. Price includes mainframe, internally contained load terminations and four RG174 output cables. | | |
| Delivery: | 30-45 days ARO. | | |

Thank you for your interest in our products. Please call me again if you require any additional information or modifications to the above quotation.

Yours truly,

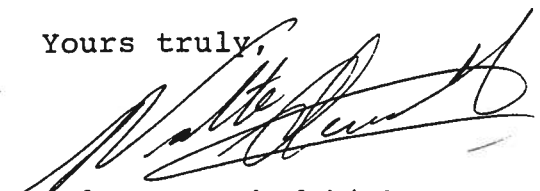

Walter J. Chudobiak
Chief Engineer

WJC:pr
Encl.

AVTECH AVR-E3-PS-R4-PEC2

JAN 63

FRONT PANEL

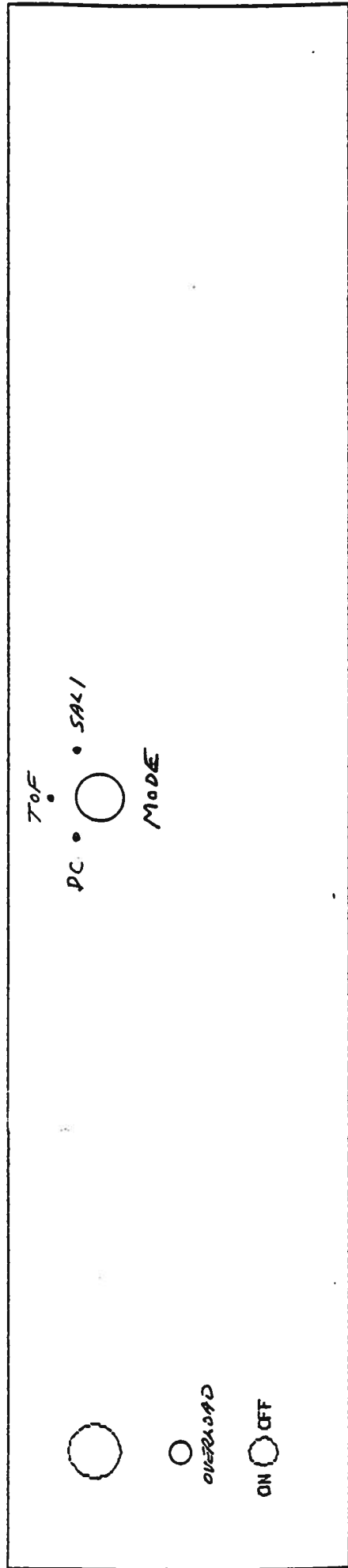

REAR PANEL

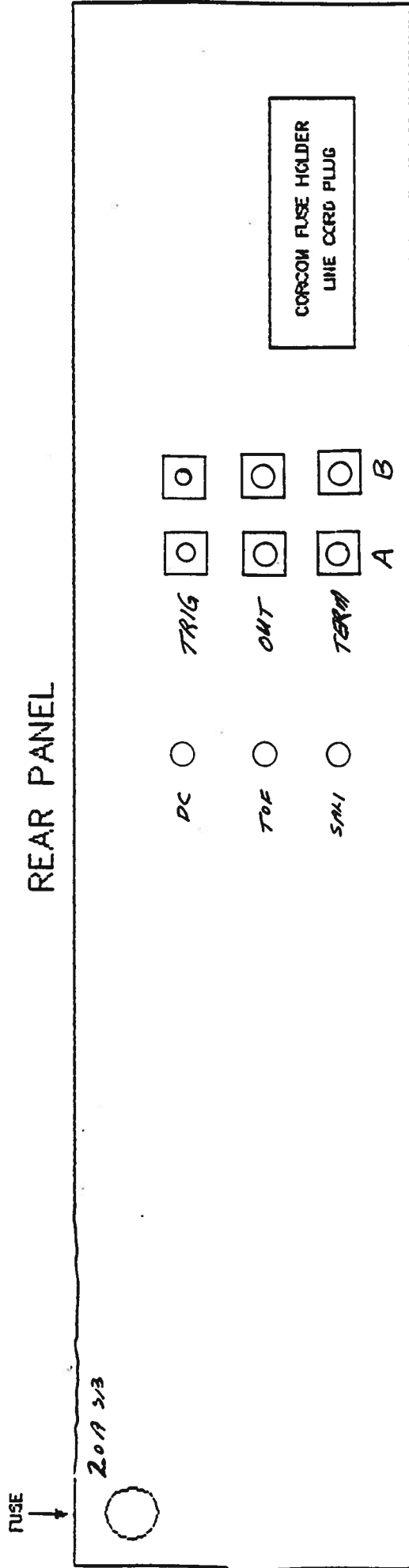

↑ FEMALE
BANNERS
(STARTS INDICATOR)

↑ SAL1
CONNECTORS

Schroff

02.28.92