



AVTECH ELECTROSYSTEMS LTD.
NANOSECOND WAVEFORM ELECTRONICS

□ P.O. BOX 265
OGDENSBURG, NY
U.S.A. 13669-0265
TEL: (315) 472-5270
FAX: (613) 226-2802

☒ BOX 5120 STN. F
OTTAWA, ONTARIO
CANADA K2C 3H4
TEL: (613) 226-5772
FAX: (613) 226-2802

INSTRUCTIONS

MODEL AVR-E3-PS-R4-PEC2A PULSE GENERATOR

S.N. :

WARRANTY

Avtech Electrosystems Ltd. warrants products of its manufacture to be free from defects in material and workmanship under conditions of normal use. If, within one year after delivery to the original owner, and after prepaid return by the original owner, this Avtech product is found to be defective, Avtech shall at its option repair or replace said defective item. This warranty does not apply to units which have been disassembled, modified or subjected to conditions exceeding the applicable specifications or ratings. This warranty is the extent of the obligation or liability assumed by Avtech with respect to this product and no other warranty or guarantee is either expressed or implied.

Fig. 2

TEST ARRANGEMENT

(INTERNAL LOAD)

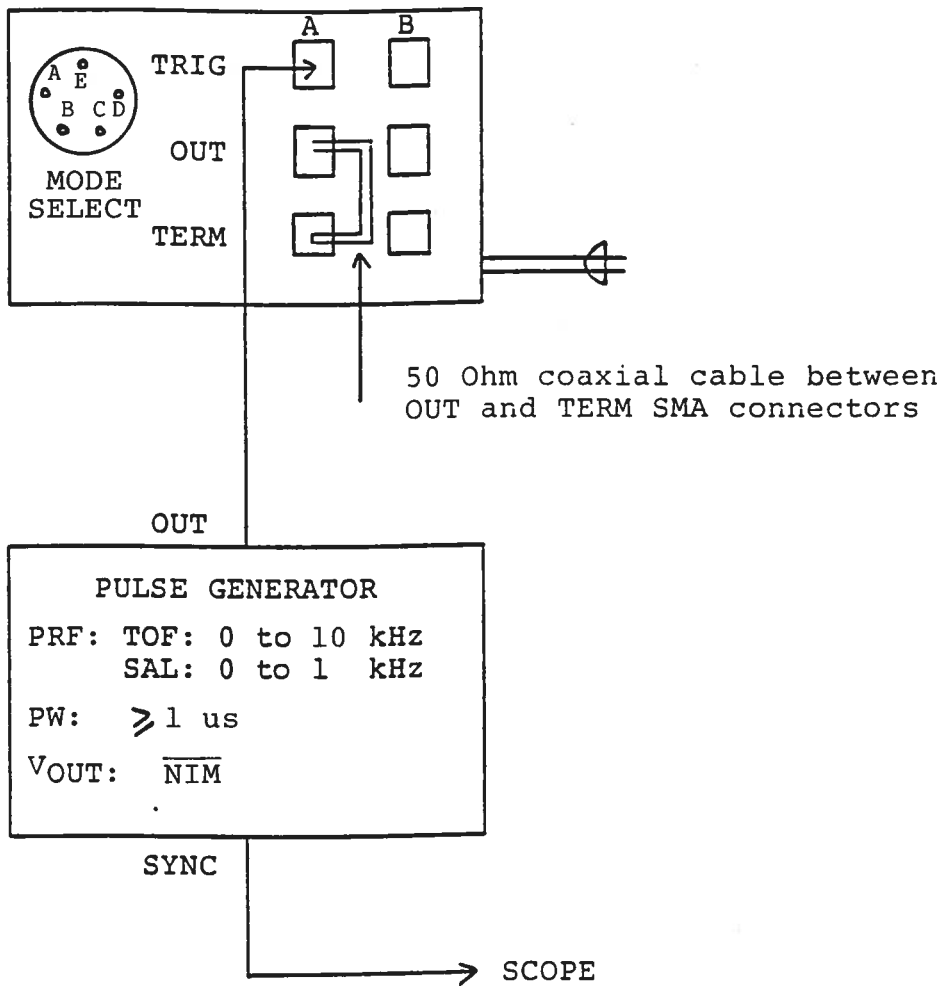

GENERAL OPERATING INSTRUCTIONS

- 1) The arrangement shown in Fig. 1 may be used to check the basic waveforms using an oscilloscope.
- 2) The relationship between the logic levels applied to PINS A and C of the MODE SELECT connector and the outputs at the OUT terminal is described by the following tenth table:

A	C	DC	TOF	SALI
0	0	1	0	0
0	1	0	0	1
1	0	0	1	0
1	1	0	0	0

- 3) With PIN A "LOW" and PIN C "LOW", the center conductor of the OUT SMA connectors are held at ground potential and so the unit does not provide any output pulses.
- 4) With PIN A "HIGH" and PIN C "LOW", the OUT SMA connectors provide the waveforms shown in Fig. 3. The one turn TAA, TAOS and TBA locking pots (see Fig. 4) are accessible in the interior of the instrument to provide the amplitude adjustments shown in Fig. 3. CAUTION: Potentials as high as 140 Volts DC are employed and exposed in the interior of the instrument (see Fig. 4).
- 5) With PIN A "LOW" and PIN C "HIGH", the OUT SMA connectors provide the waveforms shown in Fig. 5.

TOFA

TOFB

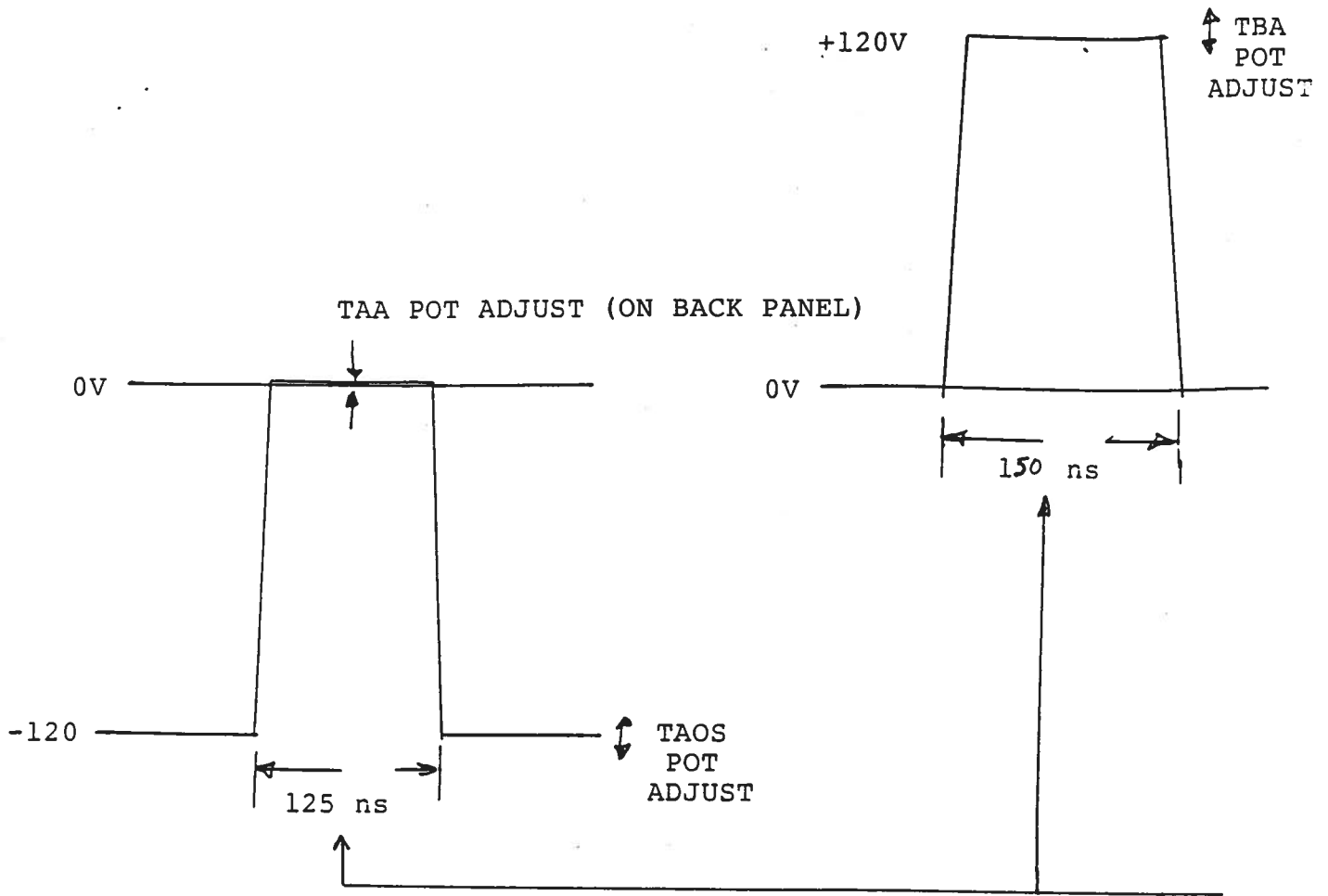

Fig. 3

TOF MODE OUTPUT WAVEFORMS

THE PW ARE
ADJUSTABLE USING THE
TWO LOCKING
POTS LOCATED ON
THE -P6 MODULES.
($\approx \pm 50$ NS)

SALI A

SALI B

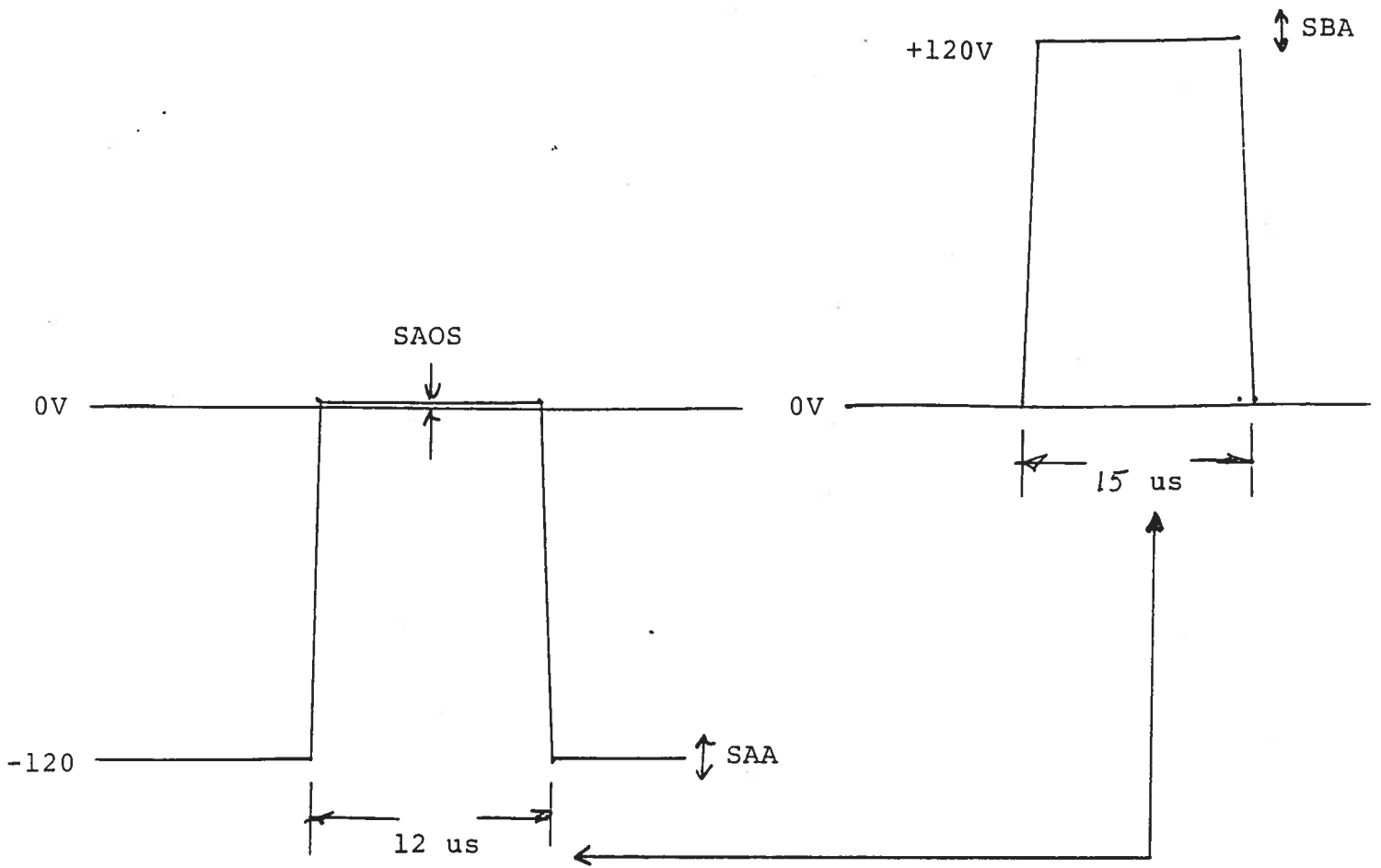
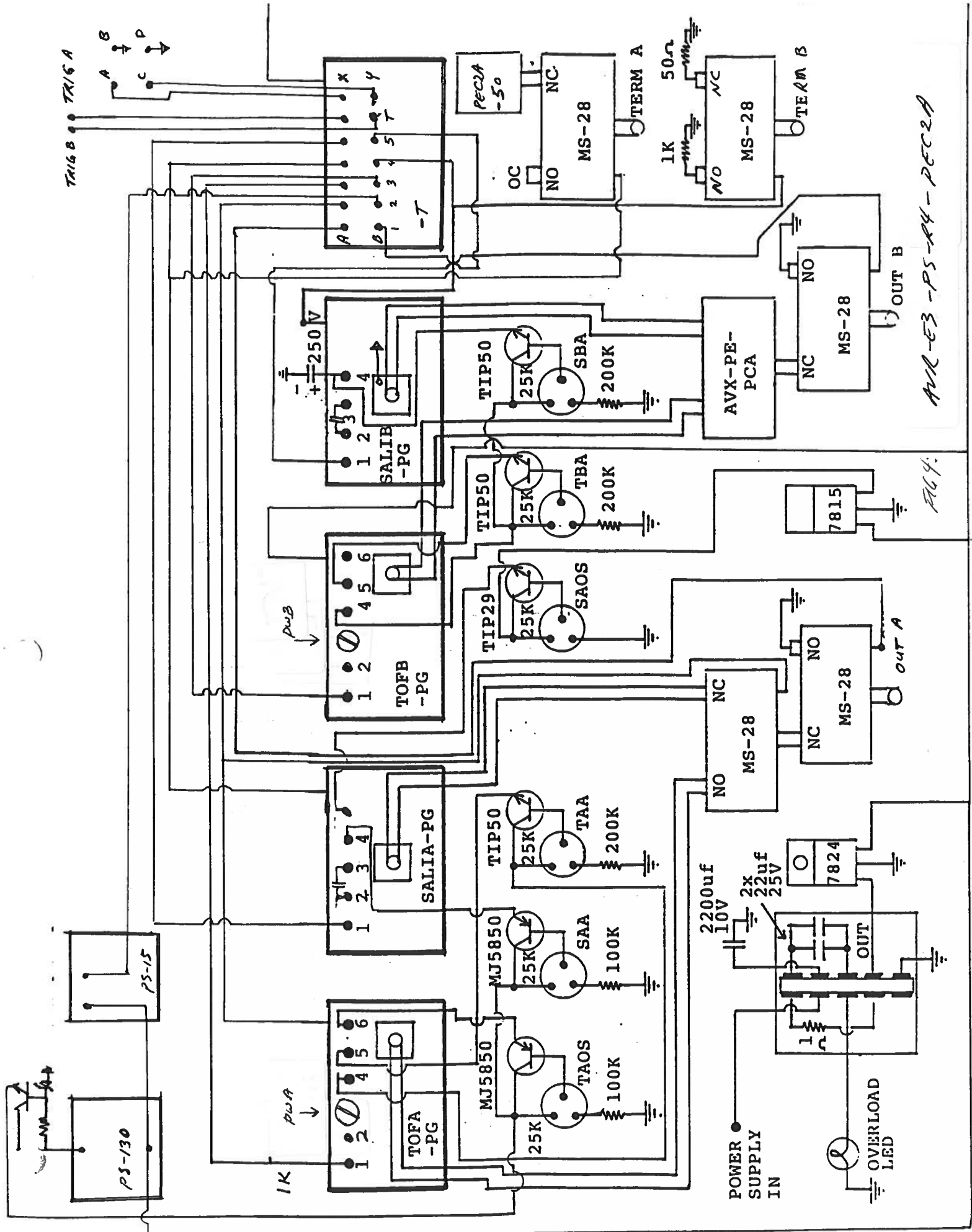

Fig. 5

SALI MODE OUTPUT WAVEFORMS

THE PW MAY
BE INCREASED BY
INCREASING THE C
BETWEEN PINS 2 + 3
ON THE SALI P6
MODULE.



AVR-E3-PS-84-PECC2A

Fig. 4

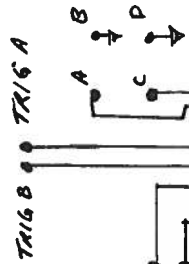

POWER SUPPLY IN

OVERLOAD LED

2200uf 10V

2x 22uf 25V

7824

7815

MS-28

MS-28

MS-28

AVX-PE-PCA

TIP50

TIP50

TIP50

MS-28

MS-28

1K

50K

100K

200K

25K

25K

25K

25K

25K

25K

25K

25K

25K

25K

25K

25K

25K

25K

25K

25K

25K

25K

25K

25K

25K

As with the TOF mode, the one turn SAA, SADS or SBA locking pots (see Fig. 4) are provided in the interior of the instrument to achieve the amplitude adjustments shown in Fig. 5.

- 6) When driving a parallel plate load, a 50 Ohm coaxial transmission line (RG 174 or better) must be used to connect the SMA OUT terminal to the parallel plate function and onto the TERM SMA. The instrument automatically provides the correct termination internally.
- 7) The propagation delay for the TOF mode is 62 ns while the propagation delay for the SALI mode is 125 ns. Minor adjustments to the propagation delays can be implemented by extending (or shortening) the lead lengths to TERMINAL 1 of the 4 pulse generator modules. Changing the lead length by several inches will modify the propagation delay by about one nanosecond.

B)

FRONT PANEL CONTROLS

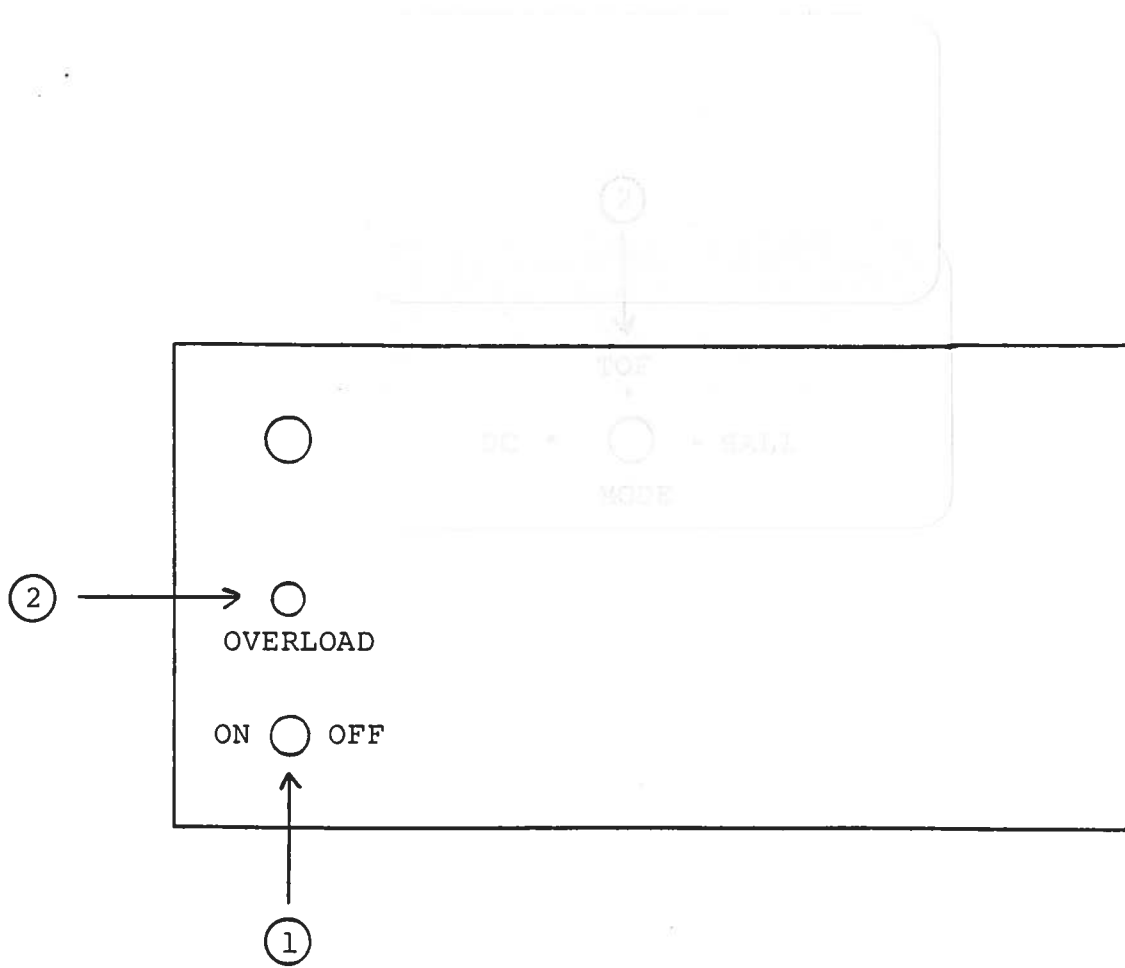

- (1) ON-OFF Switch. Applies prime power to all stages.
- (2) OVERLOAD INDICATOR. AVR units with a serial number higher than 5600 are protected by an automatic overload protective circuit which controls the front panel overload light. If the unit is overloaded (by operating at an exceedingly high duty cycle or by operating into a short circuit), the protective circuit will turn the output of the instrument OFF and turn the indicator light ON. The light will stay ON (i.e. output OFF) for about 5 seconds after which the instrument will attempt to turn ON (i.e. light OFF) for about 1 second. If the overload condition persists, the instrument will turn OFF again (i.e. light ON) for another 5 seconds. If the overload condition has been removed, the instrument will turn on and resume normal operation. Overload conditions may be removed by:
 - 1) Reducing PRF (i.e. switch to a lower range)
 - 2) Removing output load short circuit (if any)

c)

REAR PANEL CONTROLS

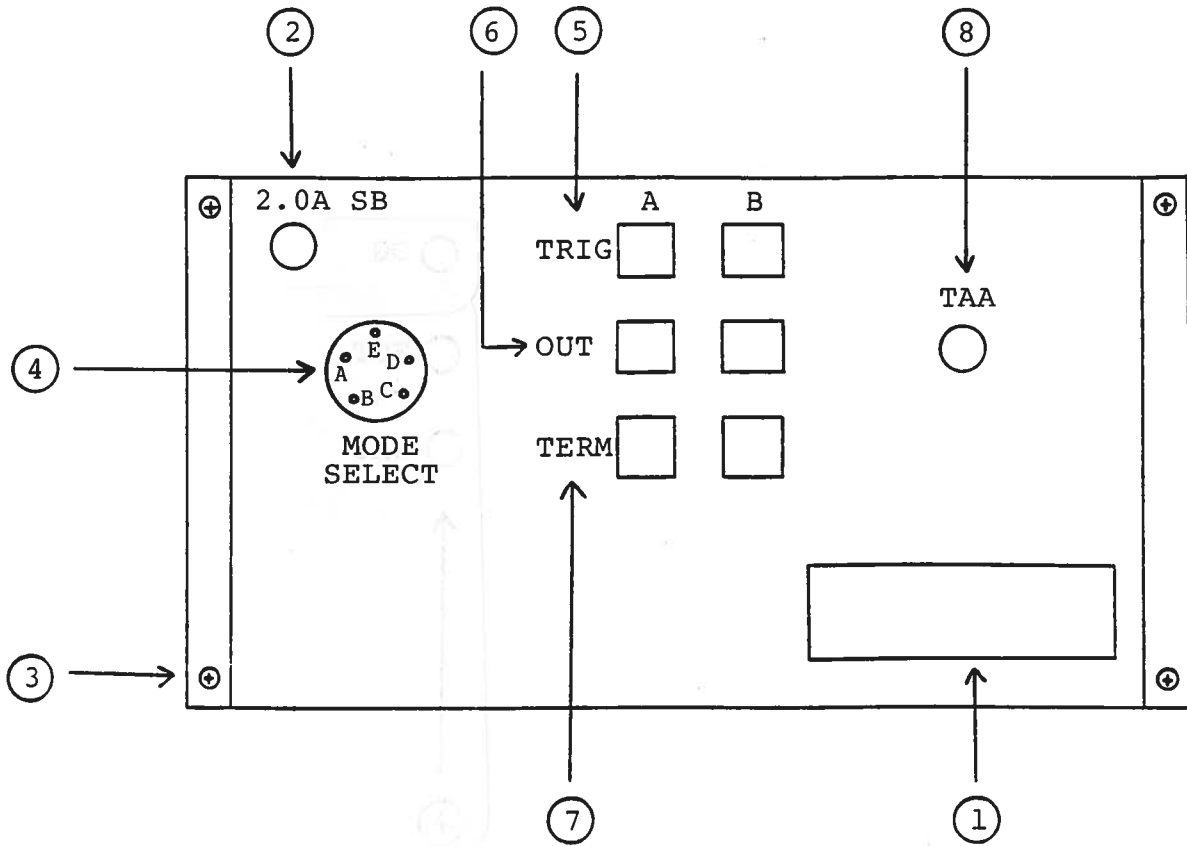

- (1) FUSED CONNECTOR, VOLTAGE SELECTOR. The detachable power cord is connected at this point. In addition, the removable cord is adjusted to select the desired input operating voltage. The unit also contains the main power fuse (0.5 A SB).
- (2) 2.0A SB. Fuse which protects the output stage if the output duty cycle rating is exceeded.
- (3) PHILLIPS SCREWS. Remove 4 rear panel PHILLIPS screws to allow the removal of the top cover (slides back).
- (4) MODE SELECT. The relationship between the logic levels applied to PINS A and C of the MODE SELECT connector and the outputs at the OUT terminal is described by the following tenth table:

A	C	DC	TOF	SALI
0	0	1	0	0
0	1	0	0	1
1	0	0	1	0
1	1	0	0	0

- (5) TRIG. SMA connector to which 1 us (or wider) $\overline{\text{NIM}}$ pulse is applied. See paragraph 1, SECTION A. Input impedance is 50 Ohms.
- (6) OUT. SMA output connectors provide waveforms shown in Figs. 3 and 5, SECTION A.
- (7) TERM. SMA connection to internal terminations as per Fig. 1, SECTION A.
- (8) IAA. One turn locking pot to set TOFA during 125 ns interval at, or near, ground potential.

D)

SYSTEM DESCRIPTION AND REPAIR PROCEDURE

The AVR unit consists of the following basic modules:

- a) PEC2A-TOFA-PG pulse generator module
- b) PEC2A-TOFB-PG pulse generator module
- c) PEC2A-SALIA-PG pulse generator module
- d) PEC2A-SALIB-PG pulse generator module
- e) PEC2A-T translation module
- f) AVX-PE-PCA power combiner module (diode OR gate)
- g) PEC2A-50 termination
- h) PS-130 power supply module (-130V)
- i) PS-15 power supply module (-15V)
- j) MS-28 SPDT coaxial switches (5)
- k) +24 Volts DC power supply board

The -PG modules generate the basic pulses and the MS-28 coaxial switches (and the AVX-PE-PCA combiner module) are used to connect the module output to the SMA OUT connector. Similarly, the MS-28 coaxial switches are used to connect the appropriate internally contained termination to the TERM SMA connector.

In the event that the unit does not provide an output, check the rear panel 1.0A SB fuse and the 0.5A SB fuse in the line cord connector assembly. If the fuses are not blown then the SL5T transistors in each of the SALI -PG modules should be checked. The SL5 elements may be accessed by removing the 1.5 x 3.0 inch cover plates on the bottom side of the chassis and extracting the SL5T elements from their sockets by means of needle nose pliers. The SL5T element is an N channel VMOS transistor in a TO 220 package and its operation may be checked on a curve tracer. When re-installing the SL5T elements, take care to insure that the short lead is placed adjacent to the black dot on the bottom of the chassis. If the SL5T transistors are replaced and no output is obtained, the unit should be returned to AVTECH for repair. If no TOF outputs are obtained, the unit should be returned to AVTECH for repair.

For additional assistance:

Tel: (315) 472-5270
Fax: (613) 226-2802

MEMORANDUM FOR THE DIRECTOR

Re: [Illegible text]

[Illegible text]

- 1. [Illegible text]
- 2. [Illegible text]
- 3. [Illegible text]
- 4. [Illegible text]
- 5. [Illegible text]

[Illegible text]

[Illegible text]

[Illegible text]

[Illegible text]