

AVTECH ELECTROSYSTEMS LTD.

NANOSECOND WAVEFORM ELECTRONICS
ENGINEERING - MANUFACTURING

□ P.O. BOX 265
OGDENSBURG
NEW YORK
13669
(315) 472-5270

☒ BOX 5120, STN. "F"
OTTAWA, ONTARIO
CANADA K2C 3H4
TEL: (613) 226-5772
FAX: (613) 226-2802

INSTRUCTIONS

MODEL AVR-E4-PS PULSE GENERATOR

S.N. :

WARRANTY

Avtech Electrosystems Ltd. warrants products of its manufacture to be free from defects in material and workmanship under conditions of normal use. If, within one year after delivery to the original owner, and after prepaid return by the original owner, this Avtech product is found to be defective, Avtech shall at its option repair or replace said defective item. This warranty does not apply to units which have been disassembled, modified or subjected to conditions exceeding the applicable specifications or ratings. This warranty is the extent of the obligation or liability assumed by Avtech with respect to this product and no other warranty or guarantee is either expressed or implied.

TEST ARRANGEMENT

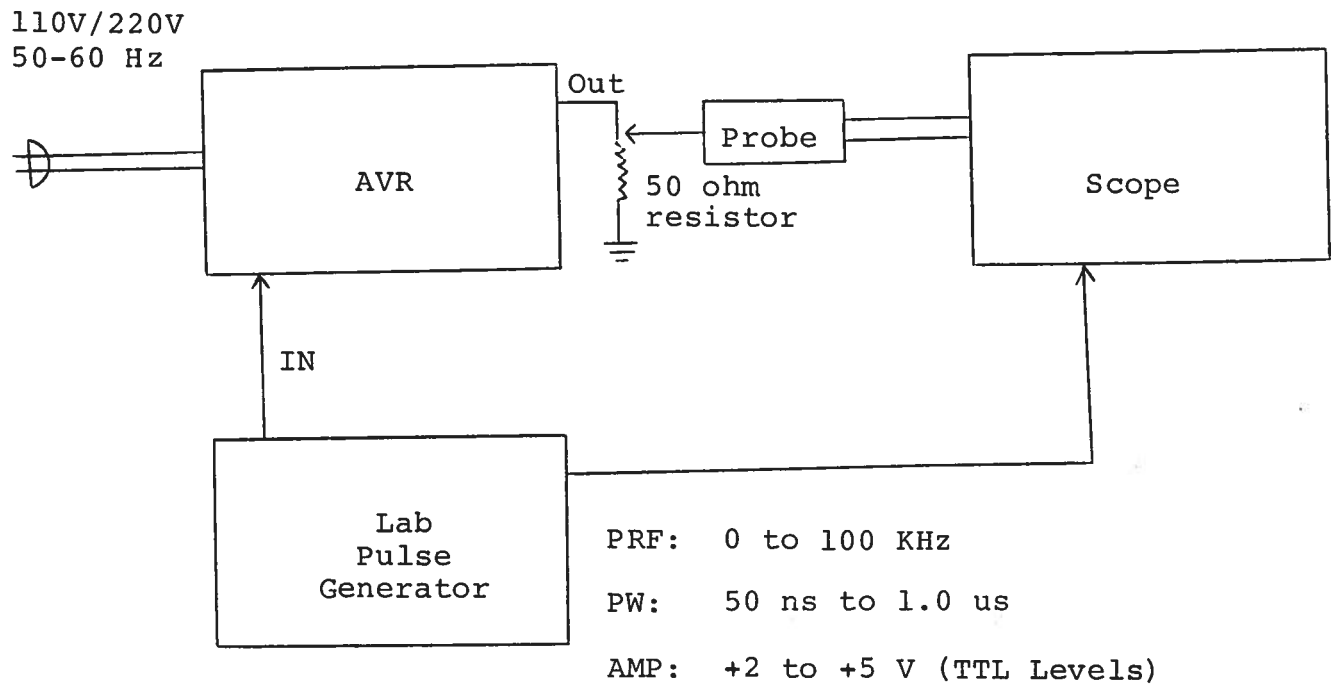

GENERAL OPERATING INSTRUCTIONS

- 1) The equipment should be connected in the general fashion shown above. A scope with a bandwidth of at least 1 GHz should be used to view output.
- 2) The output amplitude is controlled by means of the one turn potentiometer (AMP).
- 3) The output pulse width is controlled by means of the one turn potentiometer (PW).
- 4) The AVR is designed to operate into a load impedance of 50 ohm. The output switching elements may fail if the unit is inadvertently operated into a low impedance load.
- 5) WARNING: Model AVR may fail if triggered at a PRF greater than 100 KHz.
- 6) To DC offset the output pulse connect a DC power supply set to required DC offset value to the back panel terminals marked O.S. The maximum attainable DC offset voltage is ± 50 volts (OS option).
- 7) AVR units with a serial number higher than 5600 are protected by an automatic overload protective circuit which controls the front panel overload light. If the unit is overloaded (by operating at an exceedingly high duty cycle or by operating into a short circuit), the protective circuit will turn the output of the instrument OFF and turn the indicator light ON. The light will stay ON (i.e. output OFF) for about 5 seconds after which the instrument will attempt to turn ON (i.e. light OFF) for about 1 second. If the overload condition persists, the instrument will turn OFF again (i.e. light ON) for another 5 seconds. If the overload condition has been removed, the instrument will turn on and resume normal operation. Overload conditions may be removed by:
 - 1) Reducing PRF (i.e. switch to a lower range)
 - 2) Reducing pulse width (i.e. switch to a lower range)
 - 3) Removing output load short circuit (if any)

1. The first part of the report deals with the general situation in the country and the results of the survey conducted in the various regions.

2. The second part of the report deals with the results of the survey conducted in the various regions.

3. The third part of the report deals with the results of the survey conducted in the various regions.

4. The fourth part of the report deals with the results of the survey conducted in the various regions.

5. The fifth part of the report deals with the results of the survey conducted in the various regions.

6. The sixth part of the report deals with the results of the survey conducted in the various regions.

7. The seventh part of the report deals with the results of the survey conducted in the various regions.

8. The eighth part of the report deals with the results of the survey conducted in the various regions.