



AVTECH ELECTROSYSTEMS LTD.

NANOSECOND WAVEFORM ELECTRONICS
SINCE 1975

P.O. BOX 265
OGDENSBURG, NY
U.S.A. 13669-0265
TEL: (315) 472-5270
FAX: (613) 226-2802

TEL: 1-800-265-6681
FAX: 1-800-561-1970
U.S.A. & CANADA

BOX 5120 STN. F
OTTAWA, ONTARIO
CANADA K2C 3H4
TEL: (613) 226-5772
FAX: (613) 226-2802

INSTRUCTIONS

MODEL AVR-G1-C-P-OSU3 PULSE GENERATOR

S.N.:

WARRANTY

Avtech Electrosystems Ltd. warrants products of its manufacture to be free from defects in material and workmanship under conditions of normal use. If, within one year after delivery to the original owner, and after prepaid return by the original owner, this Avtech product is found to be defective, Avtech shall at its option repair or replace said defective item. This warranty does not apply to units which have been disassembled, modified or subjected to conditions exceeding the applicable specifications or ratings. This warranty is the extent of the obligation or liability assumed by Avtech with respect to this product and no other warranty or guarantee is either expressed or implied.

Fig. 1

PULSE GENERATOR TEST ARRANGEMENT

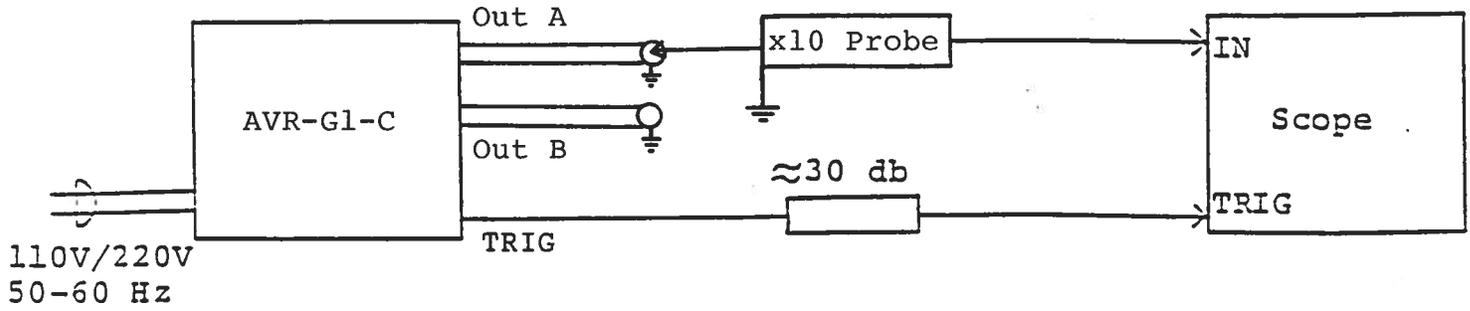

Notes:

- 1) The bandwidth capability of components and instruments used to display the pulse generator output signal (attenuators, cables, connectors, etc.) should exceed 100 MHz.
- 2) Ringing and overshoot on the leading edge may be reduced significantly by shunting the load with a 50 Ohm resistor or by a small capacitance (10 to 100 pfd).
- 3) The TRIG output channel provides TTL level signals. To avoid overdriving the TRIG input channel of some scopes, a 30 dB attenuator should be placed at the input to the scope trigger channel. The TRIG output precedes the main output when the front panel ADVANCE-DELAY switch is in the ADVANCE position. The TRIG output lags the main output when the switch is in the DELAY position.
- 4) To obtain a stable output display the PW and PRF controls on the front panel should be set mid-range while the front panel PRF RANGE switch may be in either range. The front panel TRIG toggle switch should be in the INT position. The DELAY controls and the scope triggering controls are then adjusted to obtain a stable output. The scope may then be used to set the desired PRF by rotating the PRF control and by means of the PRF RANGE switch.
- 5) The output pulse widths for Channels A and B are controlled by means of the front panel one turn PW controls. The controls should be adjusted using an oscilloscope.
- 6) The output pulse amplitudes for Channel A and Channel B are controlled by means of the front panel ten turn AMP controls.
- 7) The delay from the leading edge of the output from Channel A to leading edge of the output of Channel B is variable from 0.1 to 10.0 us using the ten turn DELAY A-B control. Channel B output (leading edge) always lags the Channel A leading edge output.

- 8) An external clock may be used to control the output PRF of the AVR unit by setting the front panel TRIG toggle switch in the EXT position and applying a 0.2 us (approx.) TTL level pulse to the TRIG BNC connector input. For operation in this mode, the scope time base must also be triggered by the external clock rather than from the TRIG output.
- 9) The unit can be converted from 110 to 220V 50-60 Hz operation by adjusting the voltage selector card in the rear panel fused voltage selector-cable connector assembly.
- 10) For additional assistance:

Tel: (613) 226-5772
Fax: (613) 226-2802

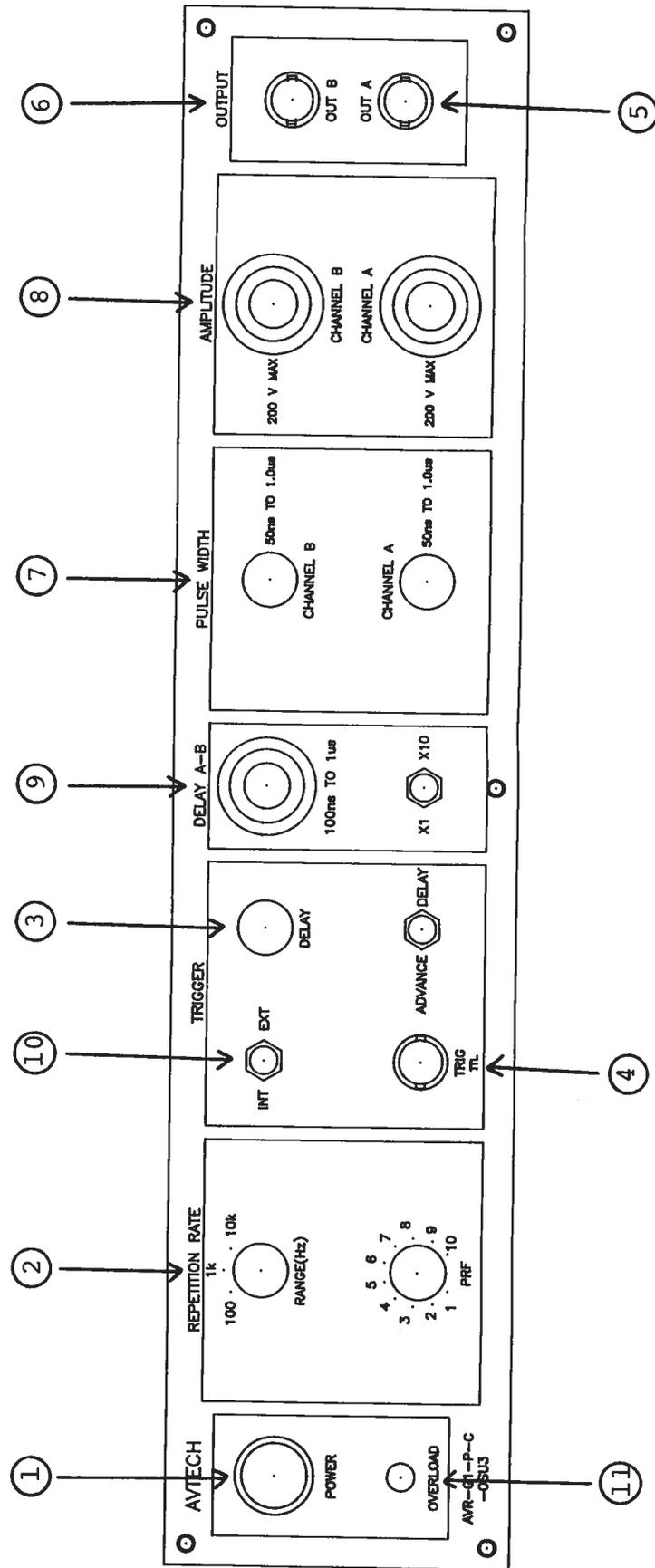

Fig. 2 FRONT PANEL CONTROLS

(1) ON-OFF Switch. Applies basic prime power to all stages.

(2) PRF Control. Controls PRF as follows:

	MIN	MAX
Range 1	10 Hz	100 Hz
Range 2	100 Hz	1 kHz
Range 3	1 kHz	10 kHz

(3) DELAY Control. Controls the relative delay between the reference output pulse provided at the TRIG output (4) and the Channel A output (5). This delay is variable over the range of 0.1 to about 1.0 us. The TRIG output precedes the main output when the ADVANCE-DELAY switch is in the ADVANCE position and lags when the switch is in the DELAY position.

(4) TRIG Output. This output is used to trigger the scope time base. The output is a TTL level 100 ns (approx.) pulse capable of driving a fifty Ohm load. The relative delay between the TRIG output and Channel A output is variable from 0.1 to \pm 1.0 us using the DELAY controls.

(5) OUT A Connector. BNC connector provides output to a fifty Ohm load (0 to +200 Volts, 50 ns to 1.0 us).

(6) OUT B Connector. BNC connector provides output to a fifty Ohm load (0 to +200 Volts, 50 ns to 1.0 us).

(7) PW Control. One turn controls which vary the output pulse widths.

(8) AMP Control. Ten turn controls which varies the output pulse amplitudes.

(9) DELAY A-B Control. The delay from the leading edge of the output from Channel A to leading edge of the output of Channel B is variable from 0.1 to 10 us using the ten turn DELAY A-B control. Channel B output (leading edge) always lags the Channel A leading edge output.

- (10) EXT-INT Control. With this toggle switch in the INT position, the PRF of the AVR unit is controlled via an internal clock which in turn is controlled by the PRF controls. With the toggle switch in the EXT position, the AVR unit requires a 0.2 us TTL level pulse applied at the TRIG input in order to trigger the output stages. In addition, in this mode, the scope time base must be triggered by the external trigger source.
- (11) AVR units with a serial number higher than 5600 are protected by an automatic overload protective circuit which controls the front panel overload light. If the unit is overloaded (by operating at an exceedingly high duty cycle or by operating into a short circuit), the protective circuit will turn the output of the instrument OFF and turn the indicator light ON. The light will stay ON (i.e. output OFF) for about 5 seconds after which the instrument will attempt to turn ON (i.e. light OFF) for about 1 second. If the overload condition persists, the instrument will turn OFF again (i.e. light ON) for another 5 seconds. If the overload condition has been removed, the instrument will turn on and resume normal operation. Overload conditions may be removed by:
- 1) Reducing PRF (i.e. switch to a lower range)
 - 2) Reducing pulse width (i.e. switch to a lower range)
 - 3) Removing output load short circuit (if any)

Fig. 3

BACK PANEL CONTROLS

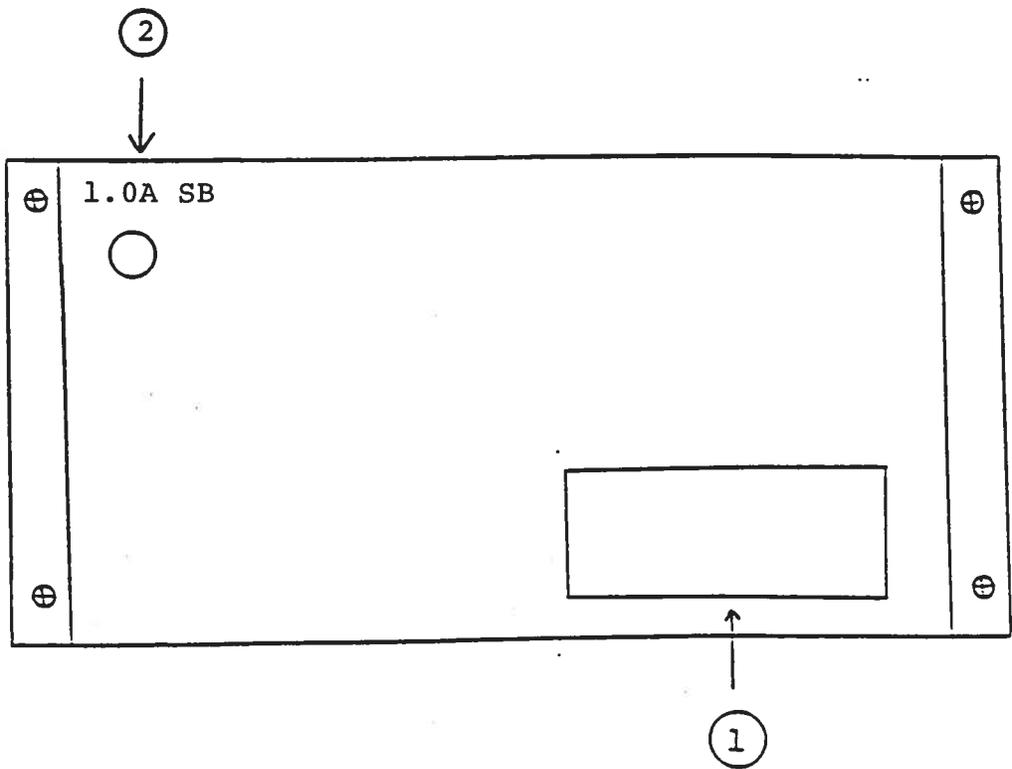

- (1) FUSED CONNECTOR, VOLTAGE SELECTOR. The detachable power cord is connected at this point. In addition, the removable cord is adjusted to select the desired input operating voltage. The unit also contains the main power fuse (0.5A SB).
- (2) 1.0A SB. This fuse limits the DC prime power supplied to the output stage and will blow in the case of severe overloading.

Fig. 4

AVR-G1-C

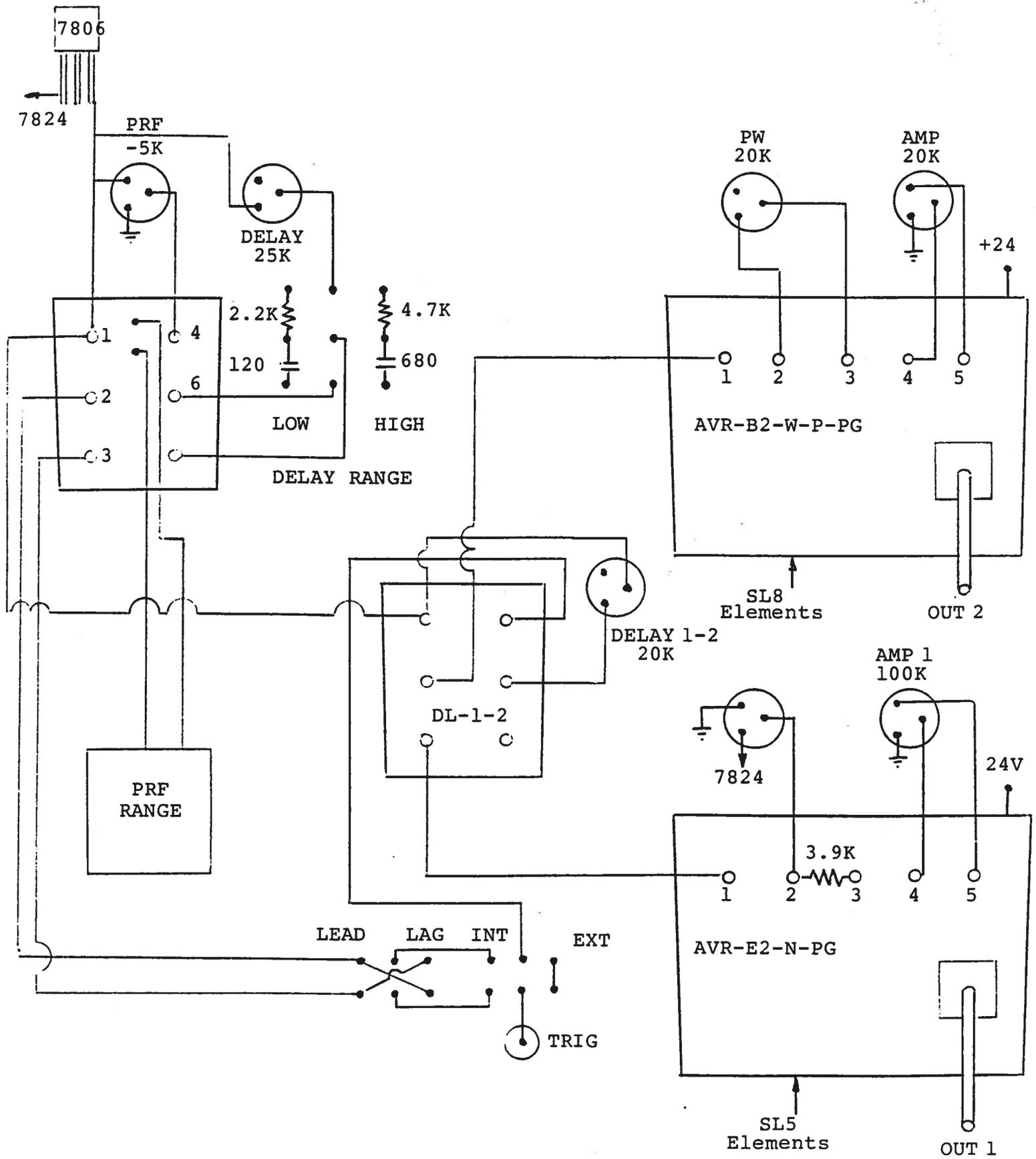
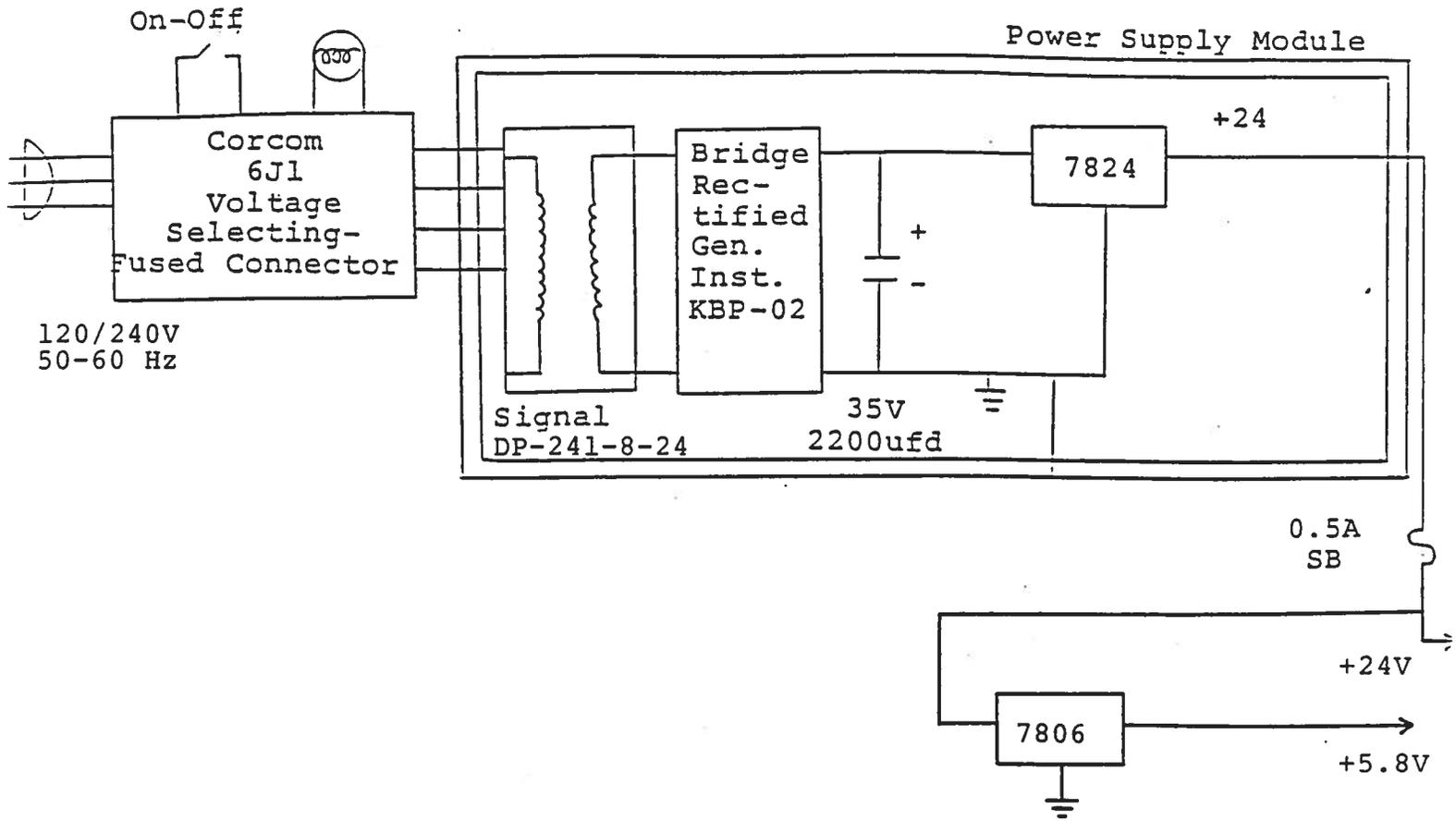

Fig. 5

SYSTEM BLOCK DIAGRAM



SYSTEM DESCRIPTION AND REPAIR PROCEDURE

The AVR-G1-C consists of the following basic modules:

- 1) AVR-G1-PG pulse generator modules (two)
- 2) AVR-CL2 clock module
- 3) AVR-G1-DLAB delay module
- 4) +24V power supply board

The modules are interconnected as shown in Fig. 4. The clock module controls the output PRF and the relative delay between the Channel A output and the TRIG outputs. The delay module controls the delay between Channel A and Channel B leading edge outputs. The PG pulse generator modules generate the output pulses. In the event of an instrument malfunction, it is most likely that the rear panel 1.0 SB fuse or some of the output switching elements (SL4) may have failed due to an output short circuit condition or to a high duty cycle condition. The switching elements may be accessed by removing the cover plate on the bottom side of the instrument. NOTE: First turn off the prime power. The elements may be removed from their sockets by means of a needle nosed pliers. The SL4 are selected VMOS power transistors in a TO 202 package and may be checked on a curve tracer. If defective, replacement units should be ordered directly from Avtech. When replacing the SL4 switching elements, take care to insure that the short lead (of the three leads) is adjacent to the black dot on the chassis. If the switching elements are not defective, then the four Phillips screws on the back panel should be removed. The top cover may then be slid off and operation of the clock and power supply modules should be checked. The clock module is functioning properly if:

- a) 0.1 us TTL level outputs are observed at pins 2 and 3.
- b) The PRF of the outputs can be varied over the range of 10 Hz to 10 kHz using the PRF and PRF RANGE controls.
- c) The relative delay between the pin 2 and 3 outputs can be varied by at least ± 1 us by the DELAY controls.

The sealed clock module must be returned to Avtech for repair or replacement if the above conditions are not observed. The power supply board generates +24V DC to power the other modules. If the voltage is less than +24V, turn off the prime power and unsolder the lead from the 7824 regulator chip on the power supply board. Solder a 100 Ohm 5 Watt resistor to the 7824 output to ground and turn on the prime power. A voltage of +24 Volts should be read. If the voltage is less then the power supply board is defective and should be repaired or replaced.

Nov. 2/94

Disk: AVR-G

Name: G1CPOSU3.INS