



AVTECH ELECTROSYSTEMS LTD.  
NANOSECOND WAVEFORM ELECTRONICS

---

□ P.O. BOX 265  
OGDENSBURG, NY  
U.S.A. 13669-0265  
TEL: (315) 472-5270  
FAX: (613) 226-2802

✕ BOX 5120 STN. F  
OTTAWA, ONTARIO  
CANADA K2C 3H4  
TEL: (613) 226-5772  
FAX: (613) 226-2802

INSTRUCTIONS

MODEL AVR-61-PS-F PULSE GENERATOR

S.N. :

### WARRANTY

Avtech Electrosystems Ltd. warrants products of its manufacture to be free from defects in material and workmanship under conditions of normal use. If, within one year after delivery to the original owner, and after prepaid return by the original owner, this Avtech product is found to be defective, Avtech shall at its option repair or replace said defective item. This warranty does not apply to units which have been disassembled, modified or subjected to conditions exceeding the applicable specifications or ratings. This warranty is the extent of the obligation or liability assumed by Avtech with respect to this product and no other warranty or guarantee is either expressed or implied.

A.

TEST ARRANGEMENT

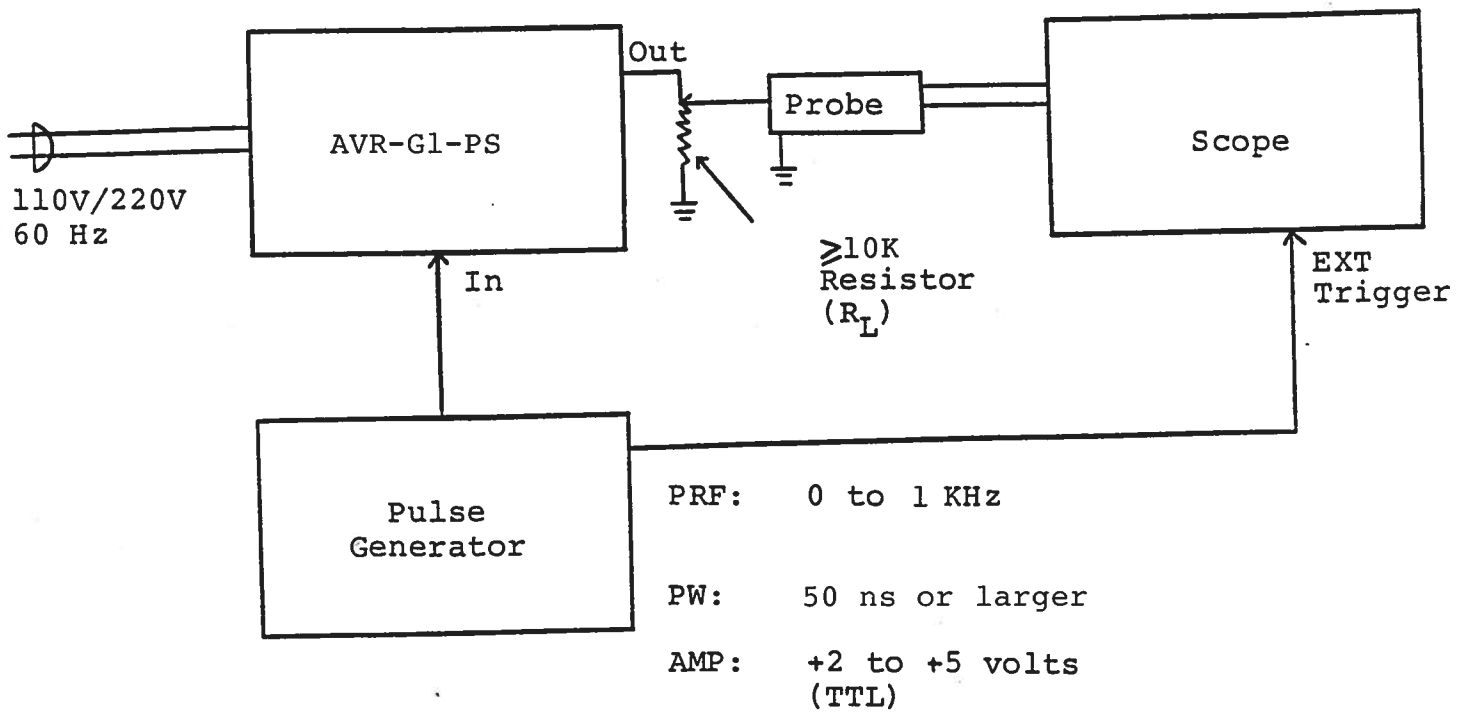

## GENERAL OPERATING INSTRUCTIONS

- 1) The equipment should be connected in the general fashion shown above. Since the AVR unit provides an output pulse rise time as low as 10 ns a fast oscilloscope (at least 50 MHz and preferably 200 MHz) should be used to display the waveform. Also, if a load of other than 50 ohm is employed, the length of coaxial cable between the AVR unit and the load should not exceed about 5 feet or the output waveform may be degraded by the resulting reflections.
- 2) The output PRF is equal to the input trigger pulse PRF.
- 3) When the MODE switch is in the A position, the output pulse width is controlled by the one turn PW control and the 4 position range switch as follows:

### PW

RANGE 1	0.1 us to 1.0 us
RANGE 2	1.0 us to 10 us
RANGE 3	10 us to 100 us
RANGE 4	100 us to 1 ms

- When the MODE switch is in the B position, the output pulse width equals the input trigger pulse width.
- 4) The output amplitude is controlled by the one turn AMP control.
  - 5) CAUTION: The AVR-G-PS unit is designed to operate into a high load impedance ( $\geq 10K$ ). The output matching element may be damaged if the unit is operated into 50 ohms (or a short circuited load).
  - 6) OVERLOAD INDICATOR. AVR units with a serial number higher than 5600 are protected by an automatic overload protective circuit which controls the front panel overload light. If the unit is overloaded (by operating at an exceedingly high duty cycle or by operating into a short circuit), the protective circuit will turn the output of the instrument OFF and turn the indicator light ON. The light will stay ON (i.e. output OFF) for about 5 seconds after which the instrument will attempt to turn ON (i.e. light OFF) for about 1 second. If the overload condition persists, the instrument will turn OFF again (i.e. light ON) for another 5 seconds. If the overload condition has been removed, the instrument will turn on and resume normal operation. Overload conditions may be removed by:
    - 1) Reducing PRF (i.e. switch to a lower range)
    - 2) Reducing pulse width (i.e. switch to a lower range)
    - 3) Removing output load short circuit (if any)

7) The AVR unit can be converted from 110 to 220V 50-60 Hz operation by adjusting the voltage selector card in the rear panel fused voltage selector-cable connector assembly.

8) For additional assistance:

Tel: (613) 226-5772

Fax: (613) 226-2802

## SYSTEM DESCRIPTION AND REPAIR PROCEDURE

The AVR-G1-PS consists of the following basic modules:

- 1) AVR-G1-PG pulse generator module
- 2) AVR-G1-PW pulse width module
- 3) AVR-G1-PS power supply module
- 4) +24V power supply board

The modules are interconnected as shown in Fig. 4.

In the event of an instrument malfunction, it is most likely that the rear panel 1.0A SB fuse or some of the output switching elements (SL9HT) may have failed due to an output short circuit condition or to a high duty cycle condition. The switching elements may be accessed by removing the cover plate on the bottom side of the instrument. NOTE: First turn off the prime power. The elements may be removed from their sockets by means of a needle nosed pliers. The SL9HT is a selected VMOS power transistor in a TO 220 packages and may be checked on a curve tracer. If defective, replacement units should be ordered directly from Avtech. When replacing the SL9HT switching elements, take care to insure that the short lead (of the three leads) is adjacent to the black dot on the chassis. If the switching elements are not defective, then the four Phillips screws on the back panel should be removed. The top cover may then be slid off and operation of the power supply module should be checked. The power supply board generates +24V DC to power the other modules. If the voltage is less than +24V, turn off the prime power and unsolder the lead from the 7824 regulator chip on the power supply board. Solder a 100 ohm 5 watt resistor to the 7824 output to ground and turn on the prime power. A voltage of +24 volts should be read. If the voltage is less then the power supply board is defective and should be repaired or replaced.

July 29/93