

AVTECH ELECTROSYSTEMS LTD.

NANOSECOND WAVEFORM ELECTRONICS
ENGINEERING - MANUFACTURING

□ P.O. BOX 265
OGDENSBURG
NEW YORK
13669
(315) 472-5270

☒ BOX 5120, STN. "F"
OTTAWA, ONTARIO
CANADA K2C 3H4
TEL: (613) 226-5772
FAX: (613) 226-2802
TELEX: 053-4591

INSTRUCTIONS

MODEL AVR-62-C-P-05-HA1 PULSE GENERATOR

S.N.: 5682 (MOD)

WARRANTY

Avtech Electrosystems Ltd. warrants products of its manufacture to be free from defects in material and workmanship under conditions of normal use. If, within one year after delivery to the original owner, and after prepaid return by the original owner, this Avtech product is found to be defective, Avtech shall at its option repair or replace said defective item. This warranty does not apply to units which have been disassembled, modified or subjected to conditions exceeding the applicable specifications or ratings. This warranty is the extent of the obligation or liability assumed by Avtech with respect to this product and no other warranty or guarantee is either expressed or implied.

Fig. 1

PULSE GENERATOR TEST ARRANGEMENT

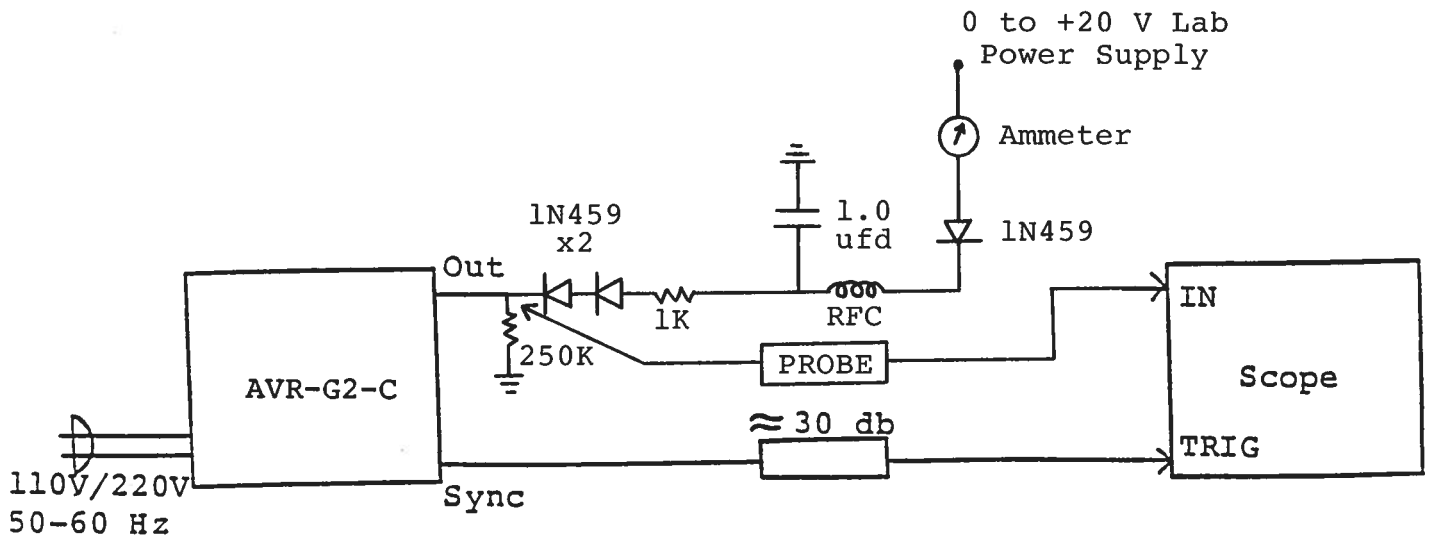

Notes:

- 1) **CAUTION:** This unit is designed to operate into a high impedance load ($R_L \gg 250K$) and may fail if operated into a low impedance load. The unit was tested with the load shown. This provided currents of up to 15 mA for the pulse generator to sink during the INTRA pulse period (when the voltage was less than about 10 volts).
- 2) The bandwidth capability of components and instruments used to display the pulse generator output signal (attenuators, cables, connectors, etc.) should exceed 100 MHz.
- 3) The sync output channel provides TTL level signals. To avoid overdriving the TRIG input channel of some scopes, a 30 db attenuator should be placed at the input to the scope trigger channel. The SYNC output precedes the main output when the front panel LEAD-LAG switch is in the LEAD position. The SYNC output lags the main output when the switch is in the LAG position.
- 4) The output pulse width is controlled by means of the front panel one turn PW control and by the PW RANGE control. The unit will operate at duty cycles as high as 90%.
- 5) To obtain a stable output display the PRF control on the front panel should be set mid range. The front panel TRIG toggle switch should be in the INT position. The DELAY controls and the scope triggering controls are then adjusted to obtain a stable output. The scope may then be used to set the desired PRF by rotating the PRF and PRF FINE controls.
- 6) The output pulse amplitude in the inter-pulse interval is controlled by means of the front panel one turn AMP control (from +50 to +250 volts). Note that when the DC-PW switch is in the DC position, the output pulse vanishes and the output amplitude is controlled by the AMP control.
- 7) The output pulse amplitude in the intra-pulse interval (the DC offset) is controlled by means of the one turn OFFSET control (from 0 to +250 volts). Note that the offset is always less than the inter-pulse amplitude.
- 8) An external clock may be used to control the output PRF of the AVR unit by setting the front panel TRIG toggle switch in the EXT position and applying a 0.2 usec (approx.) TTL level pulse to the TRIG BNC connector input. The propagation delay is variable by means of the delay control. The unit triggers on the falling edge of the TTL trigger pulse. For operation in this

mode, the scope time base must also be triggered by the external clock rather than from the SYNC output. Note that if the MODE AB switch is in the B position, the output pulse width will equal the input trigger pulse width (and the delay control is inactive).

- 9) The DELAY control controls the relative delay between the reference output pulse provided at the TRIG output and the main output. This delay is variable over the range of 0.2 usec to 100 usec. The TRIG output precedes the main output when the LEAD-LAG switch is in the LEAD position and lags when the switch is in the LAG position.
- 10) The unit is protected by an automatic overload protective circuit which controls the front panel overload light. If the unit is overloaded (by operating at an exceedingly high duty cycle or by operating into a short circuit), the protective circuit will turn the output of the instrument OFF and turn the indicator light ON. The light will stay ON (i.e. output OFF) for about 5 seconds after which the instrument will attempt to turn ON (i.e. light OFF) for about 1 second. If the overload condition persists, the instrument will turn OFF again (i.e. light ON) for another 5 seconds. If the overload condition has been removed, the instrument will turn on and resume normal operation. Overload conditions may be removed by:
 - 1) Reducing PRF (i.e. switch to a lower range)
 - 2) Reducing pulse width (i.e. switch to a lower range)
 - 3) Removing output load short circuit (if any)

Fig. 2

FRONT PANEL CONTROLS

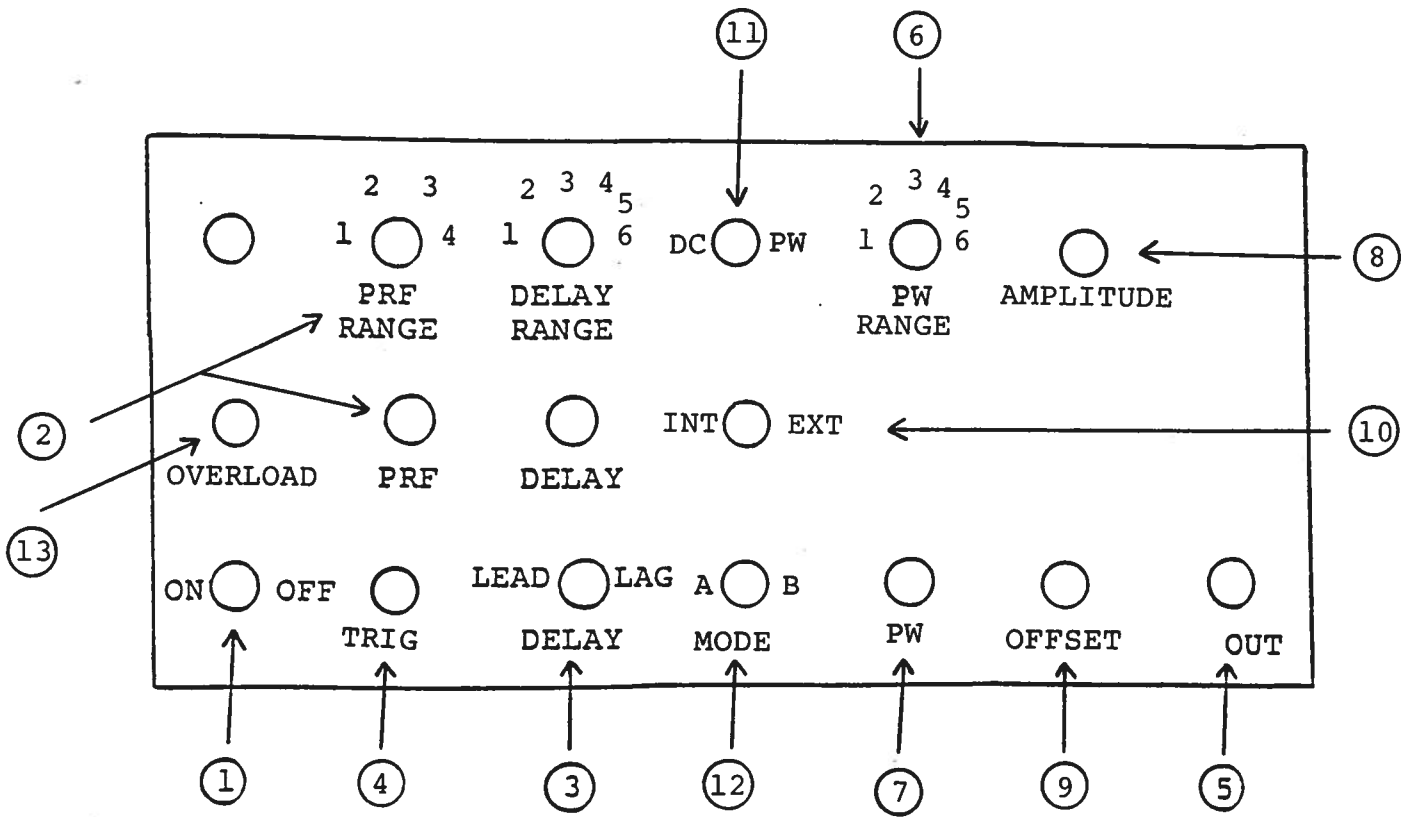

- (1) ON-OFF Switch. Applies basic prime power to all stages.
- (2) PRF Control. Varies PRF from 0.1 Hz to 1 KHz as follows:

Range 1	13 Hz	130 Hz
Range 2	130 Hz	1.3 KHz
Range 3	1.3 KHz	13 KHz
Range 4	13 KHz	130 KHz

- (3) DELAY Control. Controls the relative delay between the reference output pulse provided at the TRIG output (4) the main output (5). This delay is variable over the range of 0.2 to about 100 usec. Delay LEADS or LAGS depending on the position of the LEAD-LAG switch.

	MIN	MAX
Range 1	0.1 usec	1.0 usec
Range 2	1.0 usec	10 usec
Range 3	10 usec	100 usec
Range 4	10 usec	100 usec
Range 5	10 usec	100 usec
Range 6	10 usec	100 usec

- (4) TRIG Output. This output is used to trigger the scope time base. The output is a TTL level 100 nsec (approx.) pulse capable of driving a fifty ohm load. This output precedes the output at (5) if the two position LEAD-LAG switch is in the LEAD position. This output follows the output at (5) if the switch is in the LAG position. The delay range is variable from 0.2 usec to 100 usec. The external trigger signal is applied at this input when the EXT-INT toggle switch is in the EXT position.
- (5) OUT Connector. BNC connector provides output to a high impedance load ($\geq 250K$).
- (6) PW Control. A one turn control and 6 position range switch which varies the positive output pulse width from 0.1 usec to 100 msec. Note that the duty cycle must not exceed 90%.

	PW min	PW max
Range 1	0.1 usec	1.0 usec
Range 2	1.0 usec	10 usec
Range 3	10 usec	100 usec
Range 4	100 usec	1 msec
Range 5	1 msec	10 msec
Range 6	10 msec	100 msec

- (8) AMP Control. A one turn control which varies the inter-pulse output amplitude from +50 to +250 V (to a $R_L \geq 250K$).

- (9) OFFSET Control. A one turn control which varies the intra-pulse output amplitude (i.e. DC offset) from 0 to +250 volts.
- (10) EXT-INT Control. With this toggle switch in the INT position, the PRF of the AVR unit is controlled via an internal clock which in turn is controlled by the PRF control. With the toggle switch in the EXT position, the AVR unit requires a 0.2 usec TTL level pulse applied at the TRIG input in order to trigger the output stages. The unit triggers on the falling edge. In addition, in this mode, the scope time base must be triggered by the external trigger source.
- (11) DC-PW. Two position switch which if in DC position, removes output pulse and sets output at DC level controlled by AMP control. If in PW position, PW out is controlled by PW controls.
- (12) MODE A-B. For use when unit is triggered by externally applied TTL signal. In position A, output pulse width is controlled by PW controls (6 & 7) while in the position B, output pulse width equals the input trigger pulse width.
- (13) OVERLOAD INDICATOR. The unit is protected by an automatic overload protective circuit which controls the front panel overload light. If the unit is overloaded (by operating at an exceedingly high duty cycle or by operating into a short circuit), the protective circuit will turn the output of the instrument OFF and turn the indicator light ON. The light will stay ON (i.e. output OFF) for about 5 seconds after which the instrument will attempt to turn ON (i.e. light OFF) for about 1 second. If the overload condition persists, the instrument will turn OFF again (i.e. light ON) for another 5 seconds. If the overload condition has been removed, the instrument will turn on and resume normal operation. Overload conditions may be removed by:
- 1) Reducing PRF (i.e. switch to a lower range)
 - 2) Reducing pulse width (i.e. switch to a lower range)
 - 3) Removing output load short circuit (if any)

Fig. 3

BACK PANEL CONTROLS

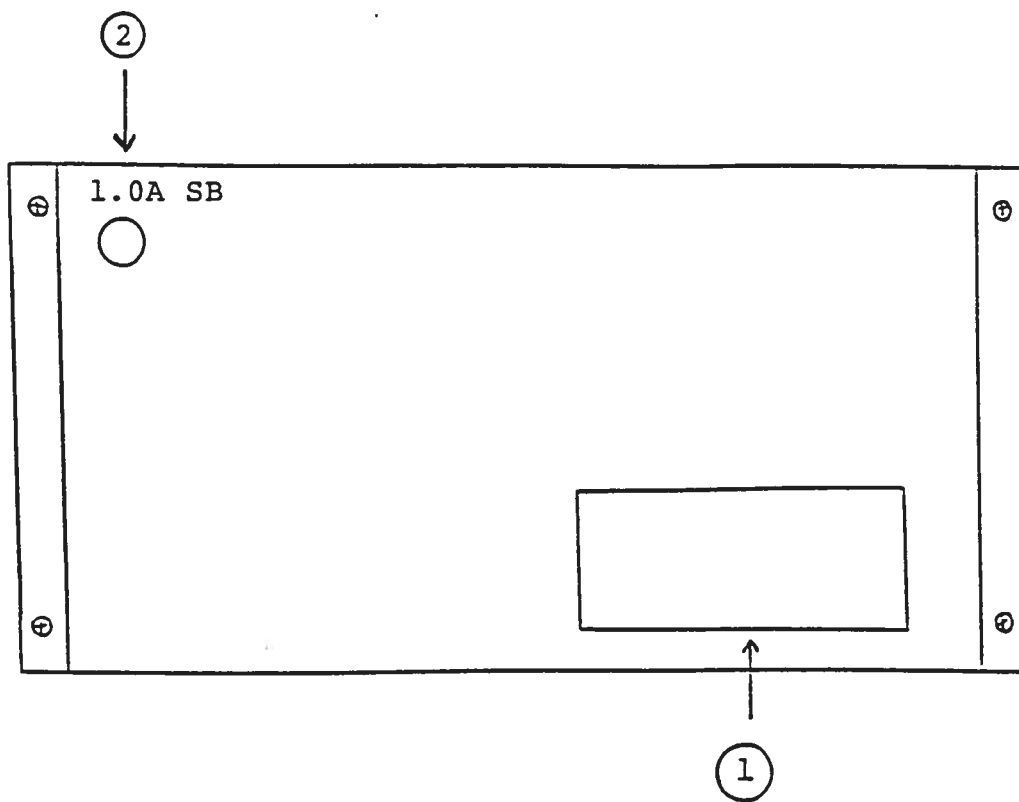

- (1) FUSED CONNECTOR, VOLTAGE SELECTOR. The detachable power cord is connected at this point. In addition, the removable cord is adjusted to select the desired input operating voltage. The unit also contains the main power fuse (0.5A SB).
- (2) 1.0A SB. Fuse which protects the output stage if the output duty cycle rating is exceeded.

SYSTEM DESCRIPTION AND REPAIR PROCEDURE

The AVR-G2-C consists of the following basic modules:

- 1) AVR-G2-PG pulse generator module
- 2) AVR-G2-CL clock module
- 3) +24V power supply board
- 4) AVR-G2-PS power supply module
- 5) AVR-G2-PW pulse width module
- 6) AVR-OL overload module

The modules are interconnected as shown in Fig. 4. The clock module controls the output PRF and the relative delay between the main output and the SYNC outputs. The PG pulse generator modules generate the output pulse. The PS module generates 0 to +250 volts to power the pulse generator module. The PW module controls the output pulse width. In the event of an instrument malfunction, it is most likely that the rear panel 1.0A SB fuse or some of the output switching elements (SL22T) may have failed due to an output short circuit condition or to a high duty cycle condition. The switching elements may be accessed by removing the cover plate on the bottom side of the instrument. NOTE: First turn off the prime power. CAUTION: Briefly ground the SL22T tabs to discharge the 250 volts power supply potential. The elements may be removed from their sockets by means of a needle nosed pliers after removing the four counter sunk 2-56 Phillips screws which attach the small aluminum heat sinks to the body of the instrument. The SL22T is a selected VMOS power transistor in a TO 220 package and may be checked on a curve tracer. If defective, replacement units should be ordered directly from Avtech. When replacing the SL22T switching elements, take care to insure that the short lead (of the three leads) is adjacent to the back of the chassis. (See following Fig.). The SL22T elements are electrically isolated from the small copper heat sink but are bonded to the heat sinks using WAKEFIELD TYPE 155 HEAT SINK ADHESIVE. If the switching elements are not defective, then the four Phillips screws on the back panel should be removed. The top cover may then be slid off and operation of the clock and power supply modules should be checked. The clock module is functioning properly if:

- a) 0.1 usec TTL level outputs are observed at pins 2 and 3.
- b) The PRF of the outputs can be varied over the range of 13 Hz to 130 KHz using the PRF controls.
- c) The relative delay between the pin 2 and 3 outputs can be varied by at least 0.1 usec to 1.0 sec by the DELAY controls.

The sealed clock module must be returned to Avtech for repair or replacement if the above conditions are not observed. The power supply board generates +24V DC to power the other modules. If the voltage is less than +24V, turn off the prime power and unsolder the lead from the 7824 regulator chip on the power supply board. Solder a 100 ohm 5 watt resistor to the 7824 output to ground and turn on the prime power. A voltage of +24 volts should be read. If the voltage is less then the power supply board is defective and should be repaired or replaced.

SL22T HEAT SINKING

BACK

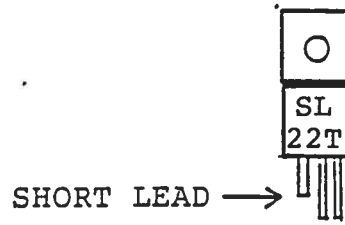
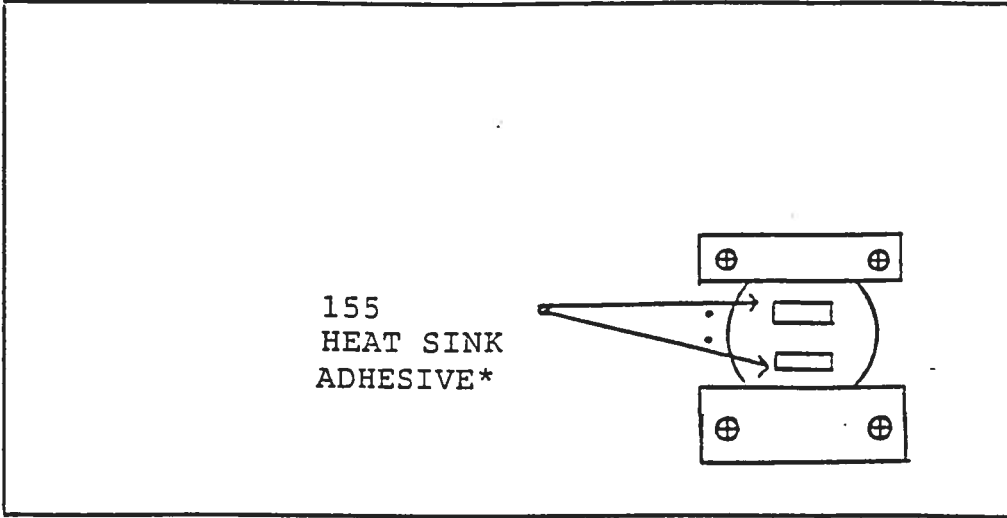

Schroff 02.19.91