

# AVTECH ELECTROSYSTEMS LTD.

NANOSECOND WAVEFORM ELECTRONICS  
ENGINEERING - MANUFACTURING

□ P.O. BOX 265  
OGDENSBURG  
NEW YORK  
13669  
(315) 472-5270

✕ BOX 5120, STN. "F"  
OTTAWA, ONTARIO  
CANADA K2C 3H4  
TEL: (613) 226-5772  
FAX: (613) 226-2802

## INSTRUCTIONS

MODEL AVR-63-C-KMP3-OL PULSE GENERATOR

S.N. :

### WARRANTY

Avtech Electrosystems Ltd. warrants products of its manufacture to be free from defects in material and workmanship under conditions of normal use. If, within one year after delivery to the original owner, and after prepaid return by the original owner, this Avtech product is found to be defective, Avtech shall at its option repair or replace said defective item. This warranty does not apply to units which have been disassembled, modified or subjected to conditions exceeding the applicable specifications or ratings. This warranty is the extent of the obligation or liability assumed by Avtech with respect to this product and no other warranty or guarantee is either expressed or implied.

Fig. 1

PULSE GENERATOR TEST ARRANGEMENT

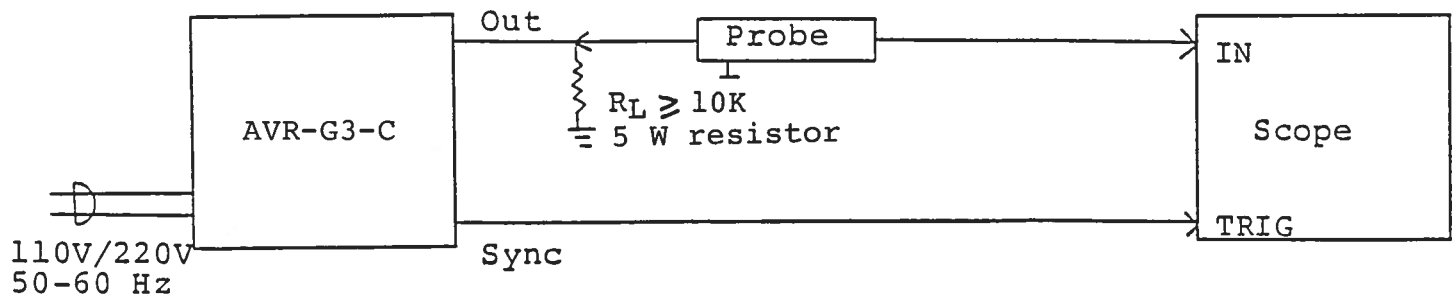

Notes:

- 1) The bandwidth capability of components and instruments used to display the pulse generator output signal (attenuators, cables, connectors, etc.) should exceed 100 MHz.
- 2) This unit was specifically designed to drive high impedance loads ( $R_L > 10K$ ). The unit may fail if operated into low impedance loads (eg.  $50 \Omega$ ).
- 3) The TRIG output channel provides TTL level signals. The TRIG output precedes the main output when the front panel LEAD-LAG switch is in the LEAD position. The TRIG output lags the main output when the switch is in the LAG position.

The DELAY control controls the relative delay between the reference output pulse provided at the TRIG output and the main output. This delay is variable over the range of 0.01 usec to 10 usec.

- 4) The output pulse widths for the positive and negative swings are controlled by means of the front panel one turn PW controls (0.5 to 10.0 us).
- 5) The output pulse amplitudes for the positive and negative swings are controlled by means of the front panel one turn AMP controls.
- 6) The TPN controls determine the time interval between the positive and negative voltage swings as follows:

	MIN	MAX
Range 1	200 usec	2 msec
Range 2	2 msec	20 msec

Note that to avoid distortion of the output pulses, the delay time TPN should be less than  $T-2PW$ .

- 7) An external clock may be used to control the output PRF of the AVR unit by setting the front panel TRIG toggle switch in the EXT position and applying a 0.2 usec (approx.) TTL level pulse to the TRIG BNC connector input. For operation in this mode, the scope time base must also be triggered by the external clock rather than from the TRIG output.
- 8) AVR-G units with a serial number higher than 5600 are protected by an automatic overload protective circuit which controls the front panel overload light. If the unit is overloaded (by operating at an exceedingly high

duty cycle or by operating into a short circuit), the protective circuit will turn the output of the instrument OFF and turn the indicator light ON. The light will stay ON (i.e. output OFF) for about 5 seconds after which the instrument will attempt to turn ON (i.e. light OFF) for about 1 second. If the overload condition persists, the instrument will turn OFF again (i.e. light ON) for another 5 seconds. If the overload condition has been removed, the instrument will turn on and resume normal operation. Overload conditions may be removed by:

- 1) Reducing PRF (i.e. switch to a lower range)
- 2) Reducing pulse width (i.e. switch to a lower range)
- 3) Removing output load short circuit (if any)

Fig. 2

FRONT PANEL CONTROLS

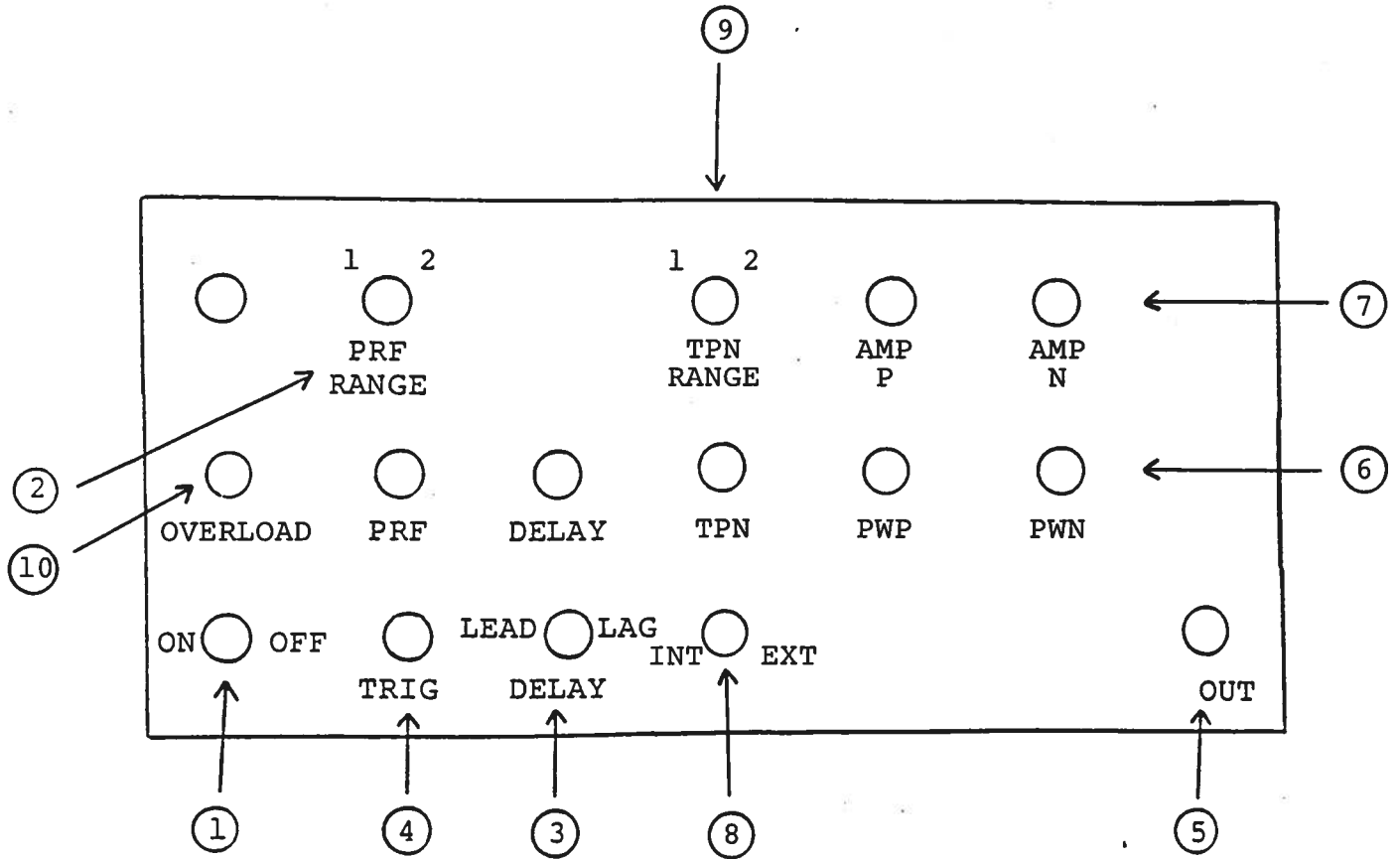

- (1) ON-OFF Switch. Applies basic prime power to all stages.
- (2) PRF Control. Varies PRF from 0.1 Hz to 1 KHz as follows:
- |         |                 |
|---------|-----------------|
| Range 1 | 10 Hz to 100 Hz |
| Range 2 | 100 Hz to 1 KHz |
- (3) DELAY Control. Controls the relative delay between the reference output pulse provided at the TRIG output (4) the main output (5). This delay is variable over the range of 0.1 to about 10 usec. Delay LEADS or LAGS depending on the position of the LEAD-LAG switch.
- (4) TRIG Output. This output is used to trigger the scope time base. The output is a TTL level 100 nsec (approx.) pulse capable of driving a fifty ohm load. This output precedes the output at (5) if the two position LEAD-LAG switch is in the LEAD position. This output follows the output at (5) if the switch is in the LAG position. The delay range is variable from 0.10 usec to 10 usec. The external trigger signal is applied at this input when the EXT-INT toggle switch is in the EXT position.
- (5) OUT Connector. BNC connector provides output to a high impedance load (>10K).
- (6) PW Controls. One turn controls which vary the output pulse width.
- (7) AMP Controls. One turn controls which varies the output pulse amplitude from 0 to  $\pm 300$  V to a high impedance load.
- (8) EXT-INT Control. With this toggle switch in the INT position, the PRF of the AVR unit is controlled via an internal clock which in turn is controlled by the PRF control. With the toggle switch in the EXT position, the AVR unit requires a 0.2 usec TTL level pulse applied at the TRIG input in order to trigger the output stages. In addition, in this mode, the scope time base must be triggered by the external trigger source.
- (9) TPN Control. The TPN controls determine the time interval between the positive and negative voltage swings as follows:

	MIN	MAX
Range 1	200 usec	2 msec
Range 2	2 msec	20 msec

Note that to avoid distortion of the output pulses, the delay time TPN should be less than T-2PW.

(10) AVR-G3-C units with a serial number higher than 5600 are protected by an automatic overload protective circuit which controls the front panel overload light. If the unit is overloaded (by operating at an exceedingly high duty cycle or by operating into a short circuit), the protective circuit will turn the output of the instrument OFF and turn the indicator light ON. The light will stay ON (i.e. output OFF) for about 5 seconds after which the instrument will attempt to turn ON (i.e. light OFF) for about 1 second. If the overload condition persists, the instrument will turn OFF again (i.e. light ON) for another 5 seconds. If the overload condition has been removed, the instrument will turn on and resume normal operation. Overload conditions may be removed by:

- 1) Reducing PRF (i.e. switch to a lower range)
- 2) Reducing pulse width (i.e. switch to a lower range)
- 3) Removing output load short circuit (if any)



Fig. 3

BACK PANEL CONTROLS

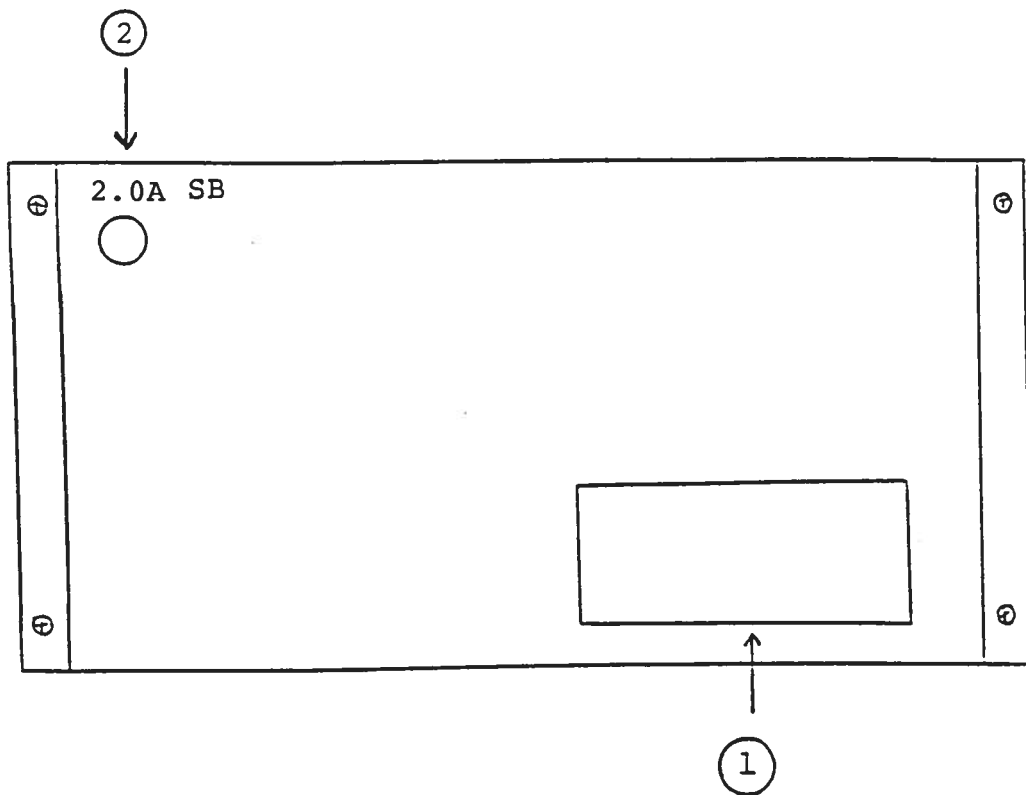

- (1) FUSED CONNECTOR, VOLTAGE SELECTOR. The detachable power cord is connected at this point. In addition, the removable cord is adjusted to select the desired input operating voltage. The unit also contains the main power fuse (0.5A SB).
- (2) 2.0A SB. Fuse which protects the output stage if the output duty cycle rating is exceeded.

POWER SUPPLY

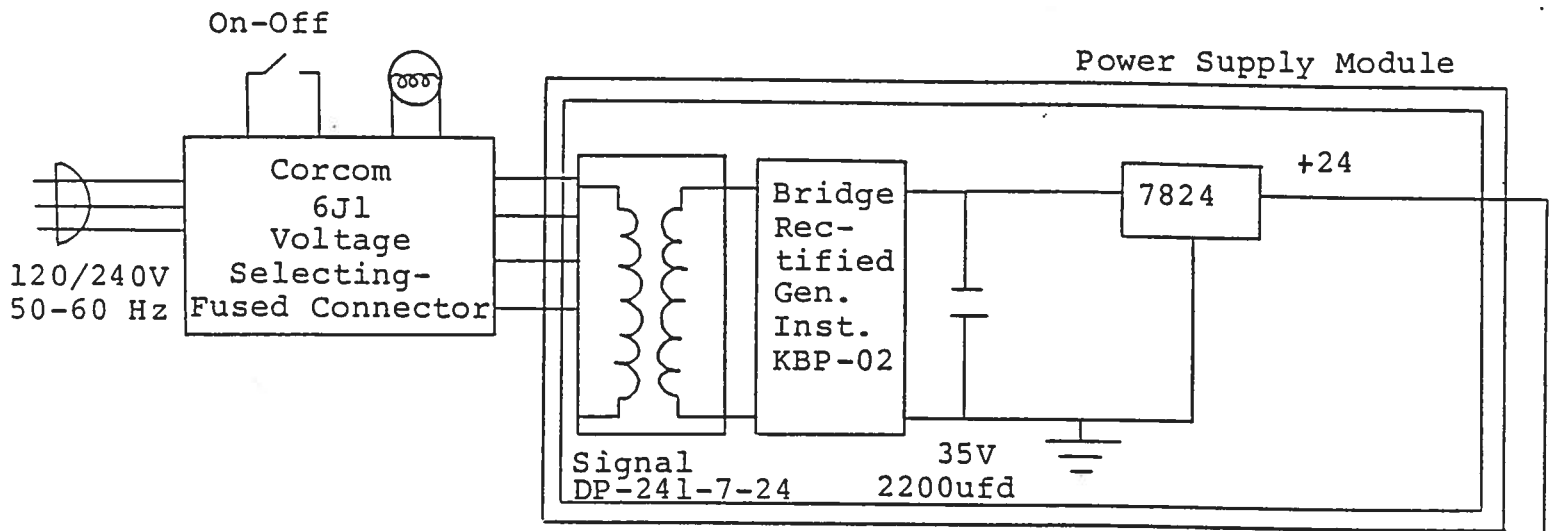

Fig. 3b

## SYSTEM DESCRIPTION AND REPAIR PROCEDURE

The AVR-G3-C consists of the following basic modules:

- 1) AVR-G3-PG pulse generator module
- 2) AVR-3-CL clock module
- 3) +24V power supply board, +36V power supply board
- 4) AVR-G3-PS power supply module
- 5) AVR-G3-PW pulse width module
- 6) AVR-G3-DG gate discharge module
- 7) AVR-OL overload (module)

In the event of an instrument malfunction, it is most likely that the 2.0 A slow blow fuse or the main power fuse on the rear panel has blown. Replace if necessary. If the unit still does not function, it is most likely that some of the output switching elements (SL22T) may have failed due to an output short circuit condition or to a high duty cycle condition. The switching elements may be accessed by removing the cover plate on the bottom side of the instrument. The cover plate is removed by removing the two 2-56 Phillips screws. NOTE: First turn off the prime power. CAUTION: Briefly ground the SL22T tabs to discharge the 300 volts power supply potential. The elements may be removed from their sockets by means of a needle nosed pliers. The SL22T is a selected VMOS power transistor in a TO 220 package and may be checked on a curve tracer. If defective, replacement units should be ordered directly from Avtech. When replacing the SL22T switching elements, take care to insure that the short lead (of the three leads) is adjacent to the back of the chassis.

Schroff

06.19.91