



AVTECH ELECTROSYSTEMS LTD.

NANOSECOND WAVEFORM ELECTRONICS
SINCE 1975

P.O. BOX 265
OGDENSBURG, NY
U.S.A. 13669-0265
TEL: (315) 472-5270
FAX: (613) 226-2802

TEL: 1-800-265-6681
FAX: 1-800-561-1970

e-mail: info@avtechpulse.com
<http://www.avtechpulse.com>

P.O. BOX 5120 STN. F
OTTAWA, ONTARIO
CANADA K2C 3H4
TEL: (613) 226-5772
FAX: (613) 226-2802

INSTRUCTIONS

MODEL AVR-G5-C-EE1 PULSE GENERATOR

S.N.:

WARRANTY

Avtech Electrosystems Ltd. warrants products of its manufacture to be free from defects in material and workmanship under conditions of normal use. If, within one year after delivery to the original owner, and after prepaid return by the original owner, this Avtech product is found to be defective, Avtech shall at its option repair or replace said defective item. This warranty does not apply to units which have been disassembled, modified or subjected to conditions exceeding the applicable specifications or ratings. This warranty is the extent of the obligation assumed by Avtech with respect to this product and no other warranty or guarantee is either expressed or implied.

TECHNICAL SUPPORT

Phone: 613-226-5772 or 1-800-265-6681

Fax: 613-226-2802 or 1-800-561-1970

E-mail: info@avtechpulse.com

World Wide Web: <http://www.avtechpulse.com>

TABLE OF CONTENTS

WARRANTY	i
TECHNICAL SUPPORT	i
FIG. 1: PULSE GENERATOR TEST ARRANGEMENT	2
GENERAL OPERATING INSTRUCTIONS	3
FIG. 2: FRONT PANEL CONTROLS	5
FRONT PANEL CONTROLS	6
FIG. 3: BACK PANEL CONTROLS	8
BACK PANEL CONTROLS	9
FIG. 4: AVR-G1-C	10
FIG. 4A: POWER SUPPLY	11
SYSTEM DESCRIPTION AND REPAIR PROCEDURE	12
PERFORMANCE CHECK SHEET	13

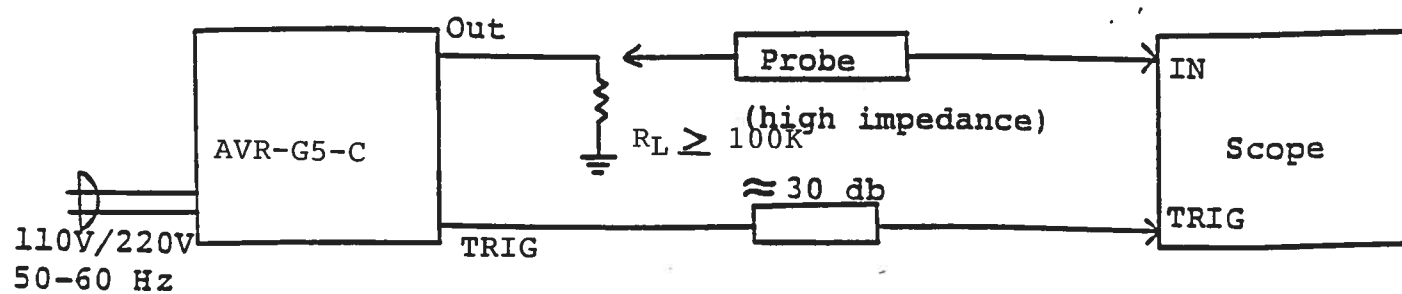
FIG. 1: PULSE GENERATOR TEST ARRANGEMENT

GENERAL OPERATING INSTRUCTIONS

- 1) The bandwidth capability of components and instruments used to display the pulse generator output signal (attenuators, cables, connectors, etc.) should exceed 50 MHz.
- 2) This unit was specifically designed to drive high impedance loads ($R_L \geq 100K$). The unit may fail if operated into low impedance loads (e.g. 50 ohm).
- 3) The TRIG output channel provides TTL level signals. To avoid overdriving the TRIG input channel of some scopes, a 30 db attenuator should be placed at the input to the scope trigger channel. The TRIG output precedes the main output when the front panel ADVANCE-DELAY switch is in the ADVANCE position. The TRIG output lags the main output when the switch is in the DELAY position.
- 4) To obtain a stable output display the PW and PRF controls on the front panel should be set mid-range. The front panel TRIG toggle switch should be in the INT position and the MODE A-B switch should be in the A position. The DELAY controls and the scope triggering controls are then adjusted to obtain a stable output. The scope may then be used to set the desired PRF by rotating the PRF control.
- 5) When the MODE A-B switch is in the A position, the output pulse width is controlled by means of the front panel 4 position range switch and one turn control as follows:

100 ns to	1 us
1 us to	10 us
0 us to	100 us
100 us to	1 ms
- 6) The output pulse amplitudes (POSITIVE AND NEGATIVE) are controlled by means of the front panel ten turn AMP controls (POSITIVE AND NEGATIVE).
- 7) An external clock may be used to control the output PRF of the AVR unit by setting the front panel TRIG MODE switch in the EXT position and applying a 0.2 us (approx.) TTL level pulse to the TRIG BNC connector input. For operation in this mode, the scope time base must also be triggered by the external clock. When triggered externally, the output pulse width will equal the input trigger pulse width if the MODE A-B switch is in the B position. When the switch is in the A position, the output pulse width is controlled by the front panel controls.
- 8) For single pulse operation, set the INT-EXT-MAN switch in the MAN position and push the single pulse button.

- 9) The source impedance of the pulser may be varied between about 5 Ohms and 50 Ohms by varying the value of the 1/2 watt resistor on the carrier PCB on the output of the -PG module. The unit was shipped with a 50 Ohm resistor in place since this amount of block-matching yields the smoothest output waveform (i.e. less ringing and overshoot). The resistor may be accessed by removing the four Phillips screws on the back panel. The top cover may then be slid back and off.
- 10) AVR units with a serial number higher than 5600 are protected by an automatic overload protective circuit which controls the front panel overload light. If the unit is overloaded (by operating at an exceedingly high duty cycle or by operating into a short circuit), the protective circuit will turn the output of the instrument OFF and turn the indicator light ON. The light will stay ON (i.e. output OFF) for about 5 seconds after which the instrument will attempt to turn ON (i.e. light OFF) for about 1 second. If the overload condition persists, the instrument will turn OFF again (i.e. light ON) for another 5 seconds. If the overload condition has been removed, the instrument will turn on and resume normal operation. Overload conditions may be removed by:
- 1) Reducing PRF (i.e. switch to a lower range)
 - 2) Reducing pulse width (i.e. switch to a lower range)
 - 3) Removing output load short circuit (if any)
- 11) If additional assistance is required:
- Tel: (613) 226-5772
Fax: (613) 226-2802

FIG. 2: FRONT PANEL CONTROLS

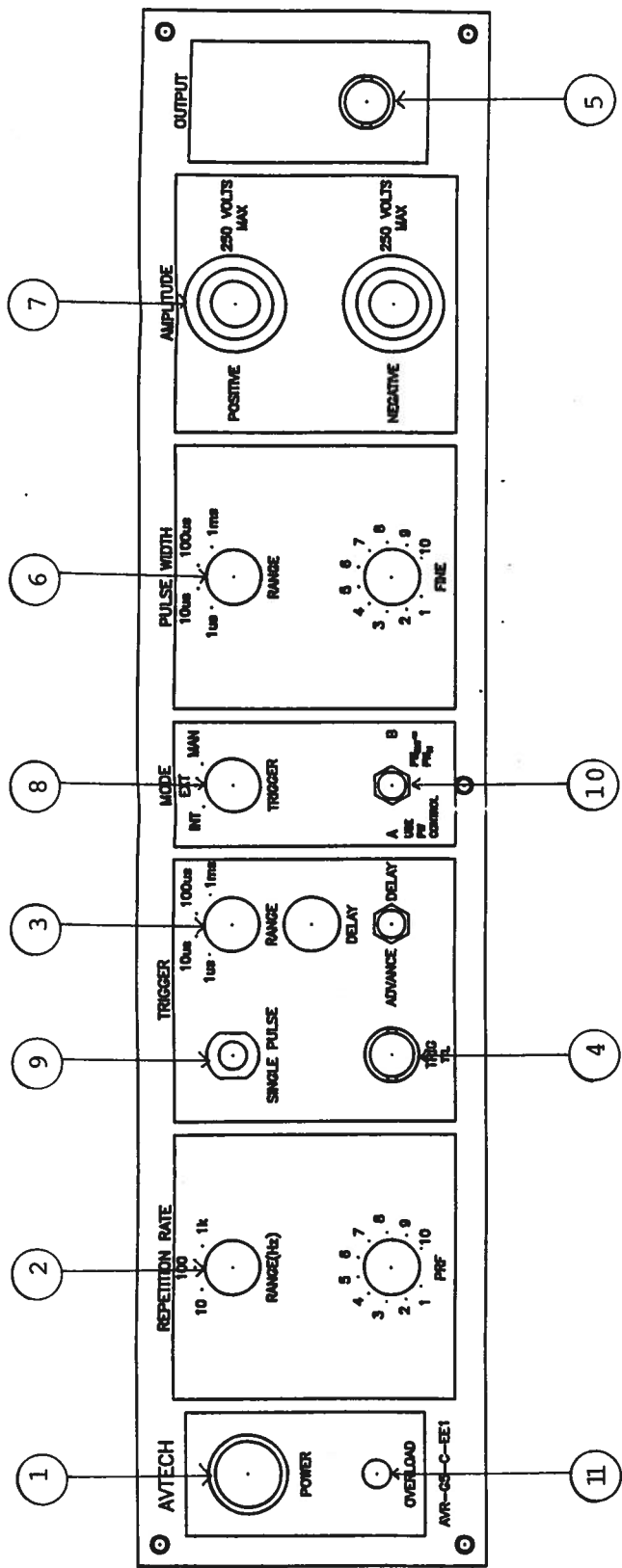

FRONT PANEL CONTROLS

- (1) ON-OFF Switch. Applies basic prime power to all stages.
- (2) PRF Control. Varies PRF from 1 Hz to 1 kHz.
- (3) DELAY Control. Controls the relative delay between the reference output pulse provided at the TRIG output (4) and the main output (5). This delay is variable over the range of 100 ns to about 1 ms. Delay LEADS or LAGS depending on the position of the ADVANCE-DELAY switch.
- (4) TRIG Output. This output is used to trigger the scope time base. The output is a TTL level 100 ns (approx.) pulse capable of driving a fifty ohm load. This output precedes the output at (5) if the two position ADVANCE-DELAY switch is in the ADVANCE position. This output follows the output at (5) if the switch is in the DELAY position. The delay range is variable from 100 ns to 1 ms. The external trigger signal is applied at this input when the EXT-INT toggle switch is in the EXT position.
- (5) OUT Connector. BNC connector provides output to a high impedance load ($\geq 100K$).
- (6) PW Control. When the MODE A-B switch is in the A position, this turn control varies the output pulse width from 100 ns to 1 ms as follows:
 - 100 ns to 1.0 us
 - 1.0 us to 10 us
 - 10 us to 100 us
 - 100 us to 1 ms
- (7) AMP Controls. Two ten turn controls which varies the output pulse amplitude from 0 to +250 V and 0 to -250 V.
- (8) EXT-INT-MAN Control. With this switch in the INT position, the PRF of the AVR unit is controlled via an internal clock which in turn is controlled by the PRF control. With the toggle switch in the EXT position, the AVR unit requires a 0.2 us TTL level pulse applied at the TRIG input in order to trigger the output stages. In addition, in this mode, the scope time base must be triggered by the external trigger source. With the MODE A-B switch in the A position the output pulse width is controlled by the PW controls. With the MODE A-B switch in the B position, the output pulse width equals the input trigger pulse width. For single pulse operation, set the INT-EXT-MAN switch in the MAN position.

- (9) **SINGLE PULSE.** For single pulse manual operation, set the front panel INT-EXT-MAN switch in the MAN position and push the SINGLE PULSE button.
- (10) **MODE A-B.** For output pulse width control via the PW controls, the MODE switch should be in the A position. When triggering via an externally applied TTL level trigger pulse, the output pulse width equals the input trigger pulse width if the MODE switch is in the B position.
- (11) **OVERLOAD INDICATOR.** AVR units with a serial number higher than 5600 are protected by an automatic overload protective circuit which controls the front panel overload light. If the unit is overloaded (by operating at an exceedingly high duty cycle or by operating into a short circuit), the protective circuit will turn the output of the instrument OFF and turn the indicator light ON. The light will stay ON (i.e. output OFF) for about 5 seconds after which the instrument will attempt to turn ON (i.e. light OFF) for about 1 second. If the overload condition persists, the instrument will turn OFF again (i.e. light ON) for another 5 seconds. If the overload condition has been removed, the instrument will turn on and resume normal operation. Overload conditions may be removed by:
- 1) Reducing PRF (i.e. switch to a lower range)
 - 2) Reducing pulse width (i.e. switch to a lower range)
 - 3) Removing output load short circuit (if any)

FIG. 3: BACK PANEL CONTROLS

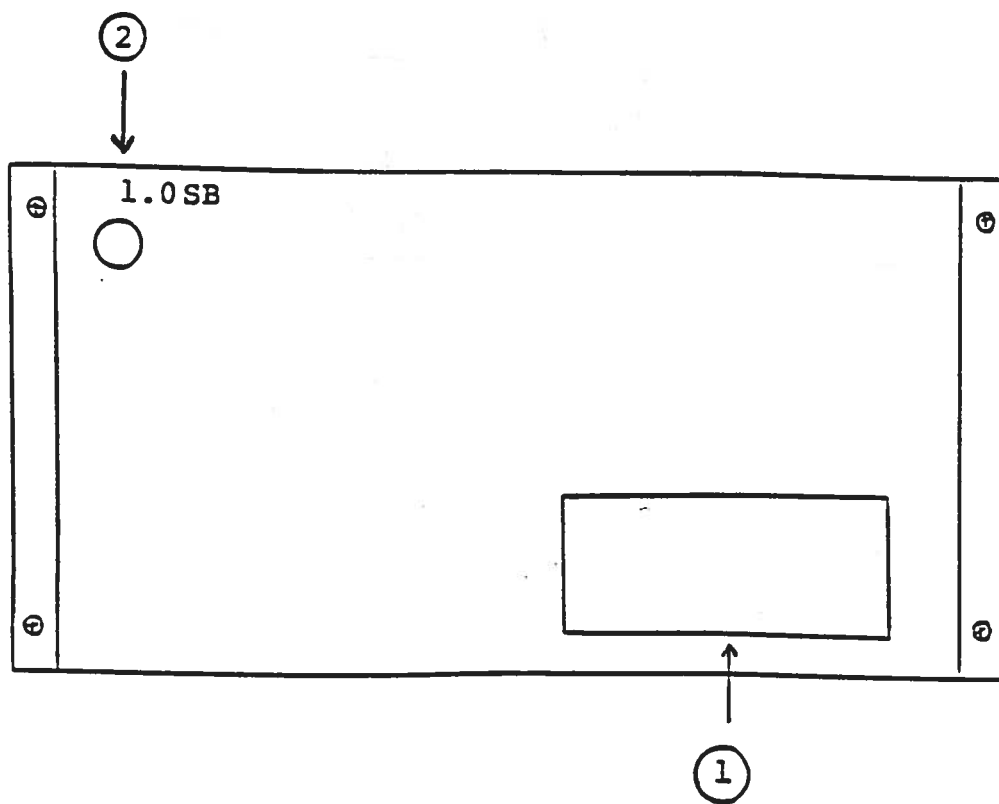

BACK PANEL CONTROLS

- (1) **FUSED CONNECTOR, VOLTAGE SELECTOR.** The detachable power cord is connected at this point. In addition, the removable cord is adjusted to select the desired input operating voltage. The unit also contains the main power fuse (0.25 Amp SB).
- (2) **1.0 SB.** Fuse which protects the output stage if the output duty cycle rating is exceeded.

FIG. 4: AVR-G1-C

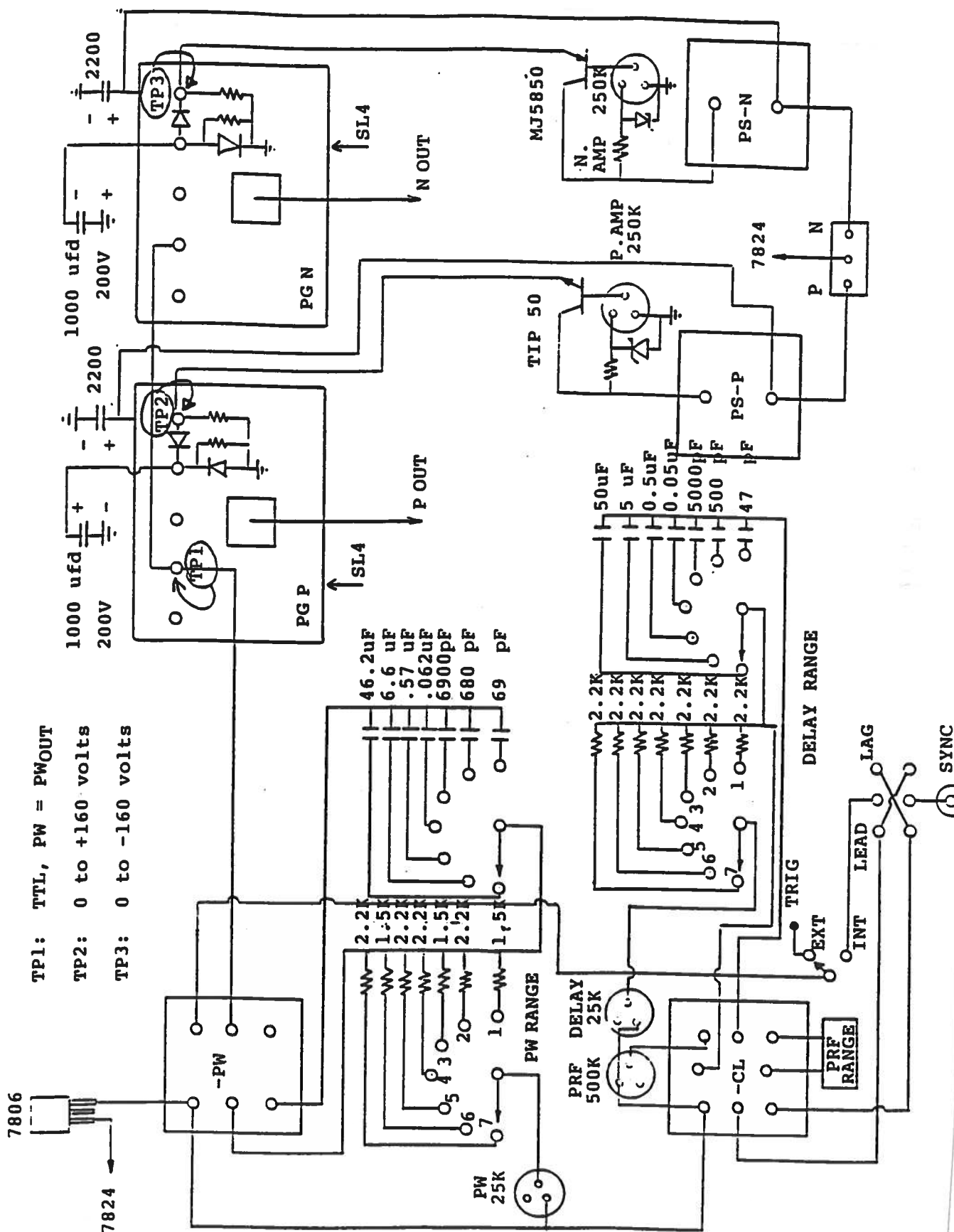
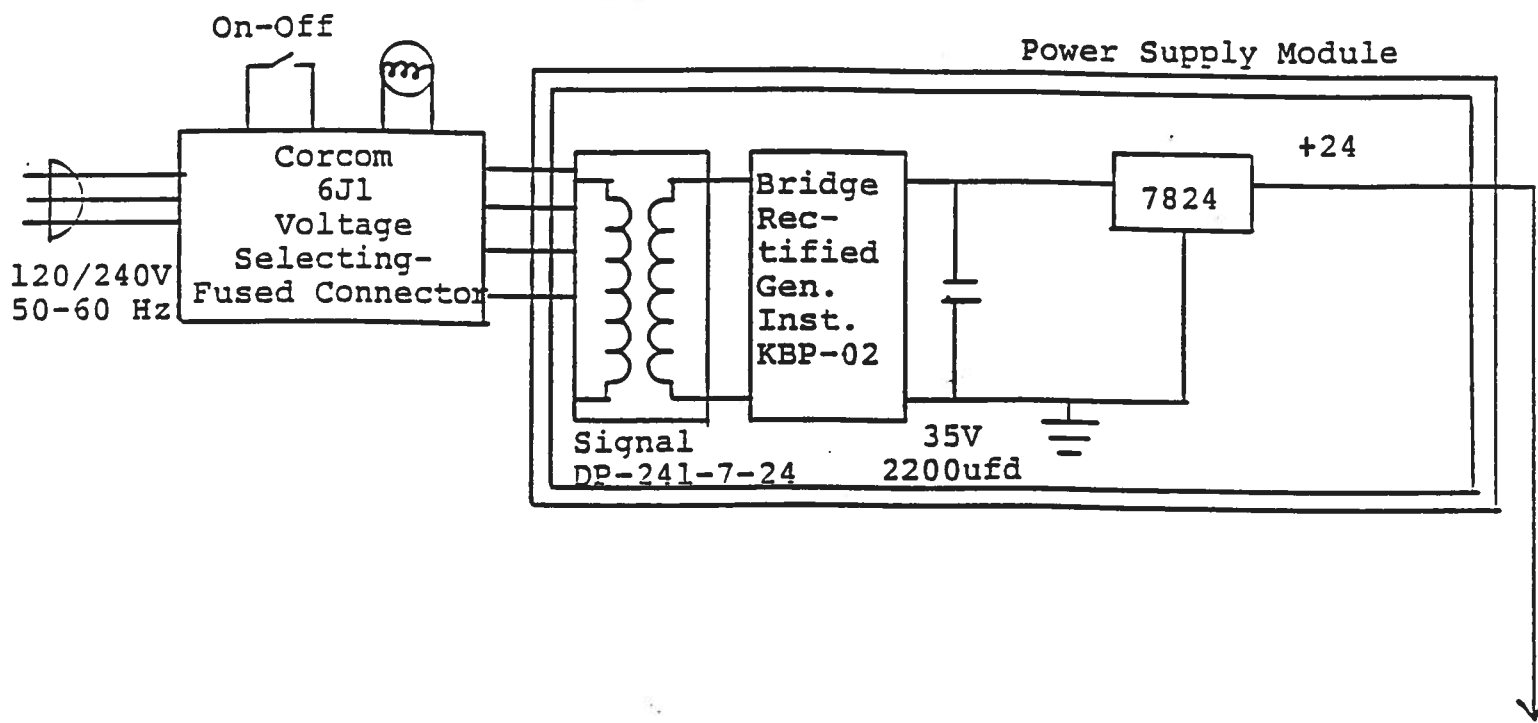

FIG. 4A: POWER SUPPLY



SYSTEM DESCRIPTION AND REPAIR PROCEDURE

The AVR-G5-C consists of the following basic modules:

- 1) AVR-G5-PG pulse generator module
- 2) AVR-G5-CL clock module
- 3) +24V power supply board
- 4) AVR-G5-PS power supply module
- 5) AVR-G5-PW pulse width module
- 6) AVR-OL overload module
- 7) AVR-G5-DB single pulse module

The modules are interconnected as shown in Fig. 4. The clock module controls the output PRF and the relative delay between the main output and the SYNC outputs. The PG pulse generator modules generate the output pulse. The PS module generates 0 to +250 volts to power the pulse generator module. The PW module controls the output pulse width. In the event of an instrument malfunction, it is most likely that the rear panel 1.0A SB fuse or some of the output switching elements (SL22T) may have failed due to an output short circuit condition or to a high duty cycle condition. The switching elements may be accessed by removing the cover plate on the bottom side of the instrument. NOTE: First turn off the prime power. CAUTION: Briefly ground the SL22T tabs to discharge the 250 volts power supply potential. The elements may be removed from their sockets by means of a needle nosed pliers. The SL22T is a selected VMOS power transistor in a TO 220 package and may be checked on a curve tracer. If defective, replacement units should be ordered directly from Avtech. When replacing the SL22T switching elements, take care to insure that the short lead (of the three leads) is adjacent to the back of the chassis. Two spare SL22T units were placed in the interior of the instrument at the time of shipping. If the switching elements are not defective, then the four Phillips screws on the back panel should be removed. The top cover may then be slid off and operation of the clock and power supply modules should be checked. The clock module is functioning properly if:

- a) 0.1 us TTL level outputs are observed at pins 2 and 3.
- b) The PRF of the outputs can be varied over the range of 1 Hz to 1 kHz using the PRF control.
- c) The relative delay between the pin 2 and 3 outputs can be varied by at least 100 ns to 1 ms by the DELAY controls.

PERFORMANCE CHECK SHEET

04.26.94