



AVTECH ELECTROSYSTEMS LTD.

NANOSECOND WAVEFORM ELECTRONICS
SINCE 1975

□ P.O. BOX 265
OGDENSBURG, NY
U.S.A. 13669-0265
TEL: (315) 472-5270
FAX: (613) 226-2802

TEL: 1-800-265-6681
FAX: 1-800-561-1970

e-mail: info@avtechpulse.com
<http://www.avtechpulse.com>

□ P.O. BOX 5120 STN. F
OTTAWA, ONTARIO
CANADA K2C 3H4
TEL: (613) 226-5772
FAX: (613) 226-2802

INSTRUCTIONS

MODEL AVR-S2-PS PULSE GENERATOR

S.N.:

WARRANTY

Avtech Electrosystems Ltd. warrants products of its manufacture to be free from defects in material and workmanship under conditions of normal use. If, within one year after delivery to the original owner, and after prepaid return by the original owner, this Avtech product is found to be defective, Avtech shall at its option repair or replace said defective item. This warranty does not apply to units which have been disassembled, modified or subjected to conditions exceeding the applicable specifications or ratings. This warranty is the extent of the obligation assumed by Avtech with respect to this product and no other warranty or guarantee is either expressed or implied.

TECHNICAL SUPPORT

Phone: 613-226-5772 or 1-800-265-6681

Fax: 613-226-2802 or 1-800-561-1970

E-mail: info@avtechpulse.com

World Wide Web: <http://www.avtechpulse.com>

TABLE OF CONTENTS

WARRANTY.....	2
TABLE OF CONTENTS.....	3
FIG. 1: PULSE GENERATOR TEST ARRANGEMENT.....	4
GENERAL OPERATING INSTRUCTIONS.....	5
REAR PANEL CONTROLS.....	6
Fig. 2: SYSTEM DESCRIPTION AND REPAIR PROCEDURE.....	7
SYSTEM DESCRIPTION AND REPAIR PROCEDURE.....	8
PERFORMANCE CHECKSHEET.....	9

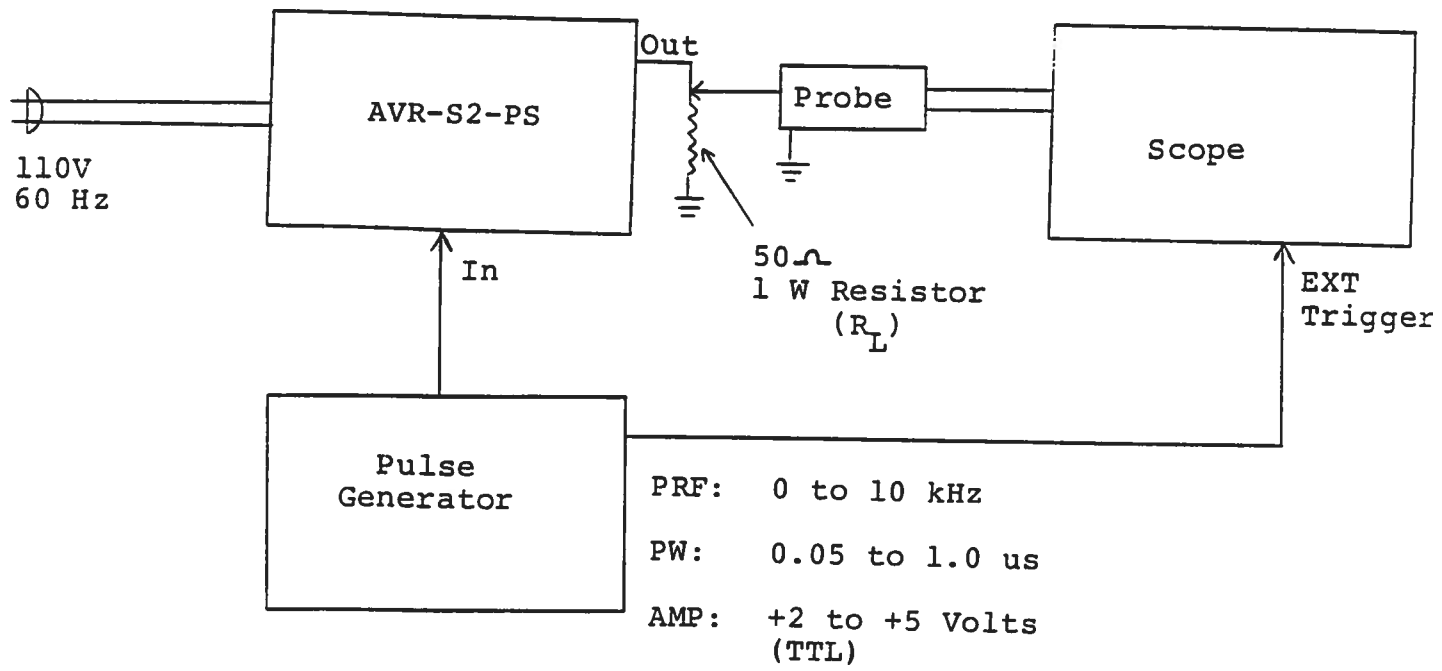
FIG. 1: PULSE GENERATOR TEST ARRANGEMENT

GENERAL OPERATING INSTRUCTIONS

- 1) The equipment should be connected in the general fashion shown above. Since the AVR unit provides an output pulse rise time as low as 2 ns a fast oscilloscope (at least 500 MHz) should be used to display the waveform.
- 2) The output PRF is equal to the input trigger pulse PRF.
- 3) The output pulse width is controlled by means of the front panel one turn PW control (ten turn for -PWT units).
- 4) The output pulse amplitude is controlled by means of the front panel one turn AMP control.
- 5) AVR-S2-PS units with a serial number higher than 5600 are protected by an automatic overload protective circuit which controls the front panel overload light. If the unit is overloaded (by operating at an exceedingly high duty cycle or by operating into a short circuit), the protective circuit will turn the output of the instrument OFF and turn the indicator light ON. The light will stay ON (i.e. output OFF) for about 5 seconds after which the instrument will attempt to turn ON (i.e. light OFF) for about 1 second. If the overload condition persists, the instrument will turn OFF again (i.e. light ON) for another 5 seconds. If the overload condition has been removed, the instrument will turn on and resume normal operation. Overload conditions may be removed by:
 1. Reducing PRF (i.e. switch to a lower range)
 2. Reducing pulse width (i.e. switch to a lower range)
 3. Removing output load short circuit (if any)
- 6) The unit can be converted from 110 to 220V 50-60 Hz operation by adjusting the voltage selector card in the rear panel fused voltage selector-cable connector assembly.
- 7) For additional assistance:

Tel: (613) 226-5772
Fax: (613) 226-2802

REAR PANEL CONTROLS

- (1) FUSED CONNECTOR, VOLTAGE SELECTOR. The detachable power cord is connected at this point. In addition, the removable cord is adjusted to select the desired input operating voltage. The unit also contains the main power fuse (0.25 A SB).
- (2) 1.0A SB. Fuse which protects the output stage if the output duty cycle rating is exceeded.
- (3) DC OFFSET Input. To DC offset the output pulse, connect a DC power supply set to the desired offset value to these terminals. The maximum allowable DC offset voltage is +50 volts, +200 mA. (Option).

Fig. 2: SYSTEM DESCRIPTION AND REPAIR PROCEDURE

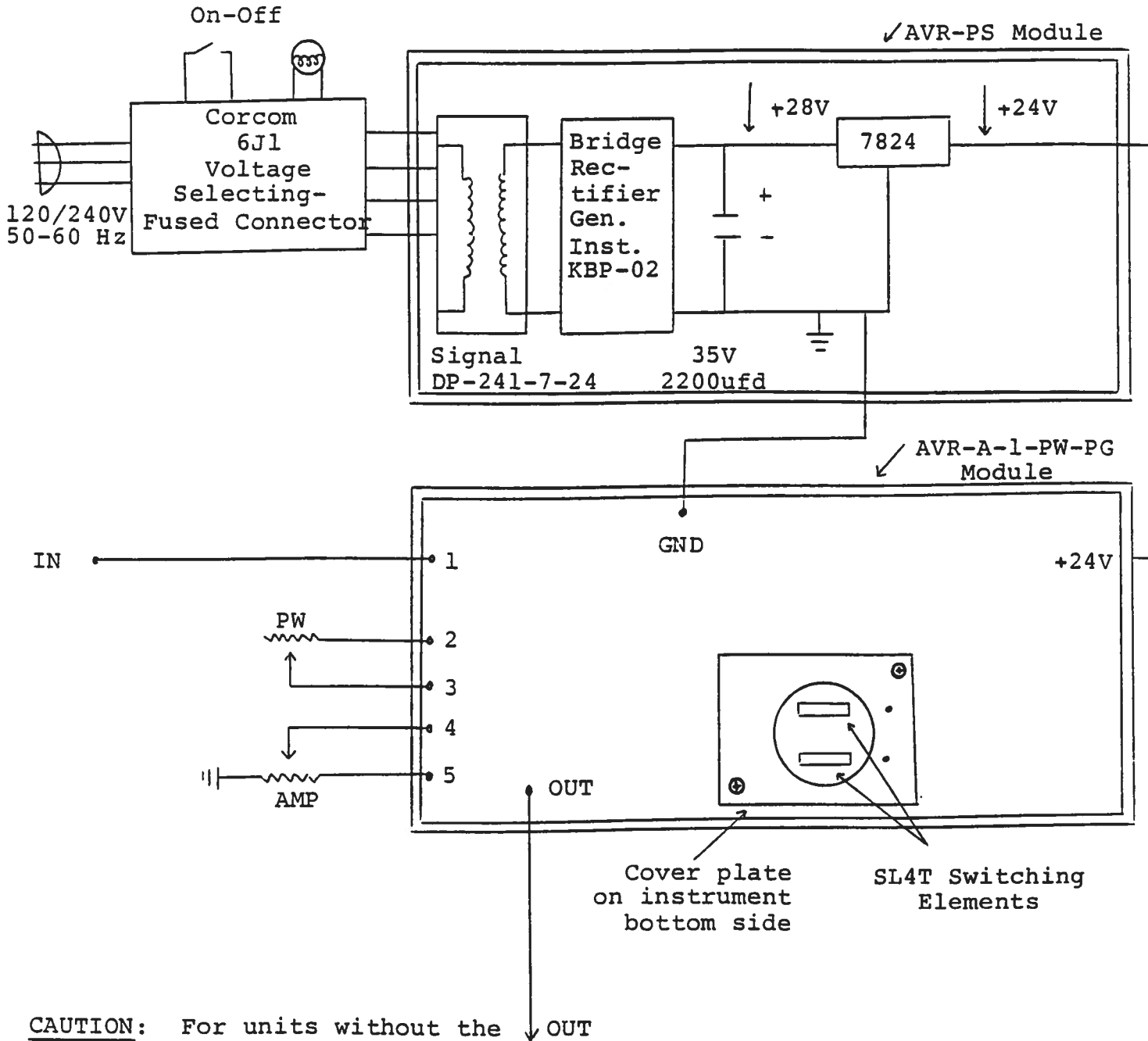

CAUTION: For units without the -EA option potentials as high as 220V DC exist on the AMP pot leads and associated terminals

SYSTEM DESCRIPTION AND REPAIR PROCEDURE

The AVR-S2-PS consists of the following basic modules:

- 1) AVR-S2-PG pulse generator module
- 2) AVR-OL overload module
- 3) AVR-TRF transition module
- 4) +24V power supply board

In the event of an instrument malfunction, it is most likely that the rear panel 1.0A SB fuse or some of the output switching elements (SL4T) may have failed due to an output short circuit condition or to a high duty cycle condition. The switching elements may be accessed by removing the cover plate on the bottom side of the instrument.

NOTE: First turn off the prime power. The elements may be removed from their sockets by means of needle nosed pliers. The SL4T is a selected VMOS power transistor in a TO 220 packages and may be checked on a curve tracer. If defective, replacement units should be ordered directly from Avtech. When replacing the SL4T switching elements, take care to insure that the short lead (of the three leads) is adjacent to the black dot on the chassis.

From WP Sept 93

-OS

-PWT

Updated to Word May 3/99