



AVTECH ELECTROSYSTEMS LTD.

NANOSECOND WAVEFORM ELECTRONICS
SINCE 1975

□ P.O. BOX 265
OGDENSBURG, NY
U.S.A. 13669-0265
TEL: (315) 472-5270
FAX: (613) 226-2802

TEL: 1-800-265-6681
FAX: 1-800-561-1970

e-mail: info@avtechpulse.com
<http://www.avtechpulse.com>

□ P.O. BOX 5120 STN. F
OTTAWA, ONTARIO
CANADA K2C 3H4
TEL: (613) 226-5772
FAX: (613) 226-2802

INSTRUCTIONS

MODEL AVRF-B2-PS-SSRCB2 PULSE GENERATOR

S.N.:

WARRANTY

Avtech Electrosystems Ltd. warrants products of its manufacture to be free from defects in material and workmanship under conditions of normal use. If, within one year after delivery to the original owner, and after prepaid return by the original owner, this Avtech product is found to be defective, Avtech shall at its option repair or replace said defective item. This warranty does not apply to units which have been disassembled, modified or subjected to conditions exceeding the applicable specifications or ratings. This warranty is the extent of the obligation assumed by Avtech with respect to this product and no other warranty or guarantee is either expressed or implied.

TECHNICAL SUPPORT

Phone: 613-226-5772 or 1-800-265-6681

Fax: 613-226-2802 or 1-800-561-1970

E-mail: info@avtechpulse.com

World Wide Web: <http://www.avtechpulse.com>

TABLE OF CONTENTS

WARRANTY	2
TABLE OF CONTENTS	3
FIG. 1: PULSE GENERATOR TEST ARRANGEMENT.....	4
FIG. 2: OUTPUT WAVEFORM	5
GENERAL OPERATING INSTRUCTIONS.....	6
FIG. 3: FRONT PANEL CONTROLS	8
FRONT PANEL CONTROLS	9
FIG. 4: BACK PANEL CONTROLS.....	10
BACK PANEL CONTROLS.....	11
TOP COVER REMOVAL AND RACK MOUNTING.....	12
SYSTEM DESCRIPTION AND REPAIR PROCEDURE	13
POWER SUPPLY AND FUSE REPLACEMENT	14
ORIGINAL QUOTATION.....	16
PERFORMANCE CHECK SHEET	17

FIG. 1: PULSE GENERATOR TEST ARRANGEMENT

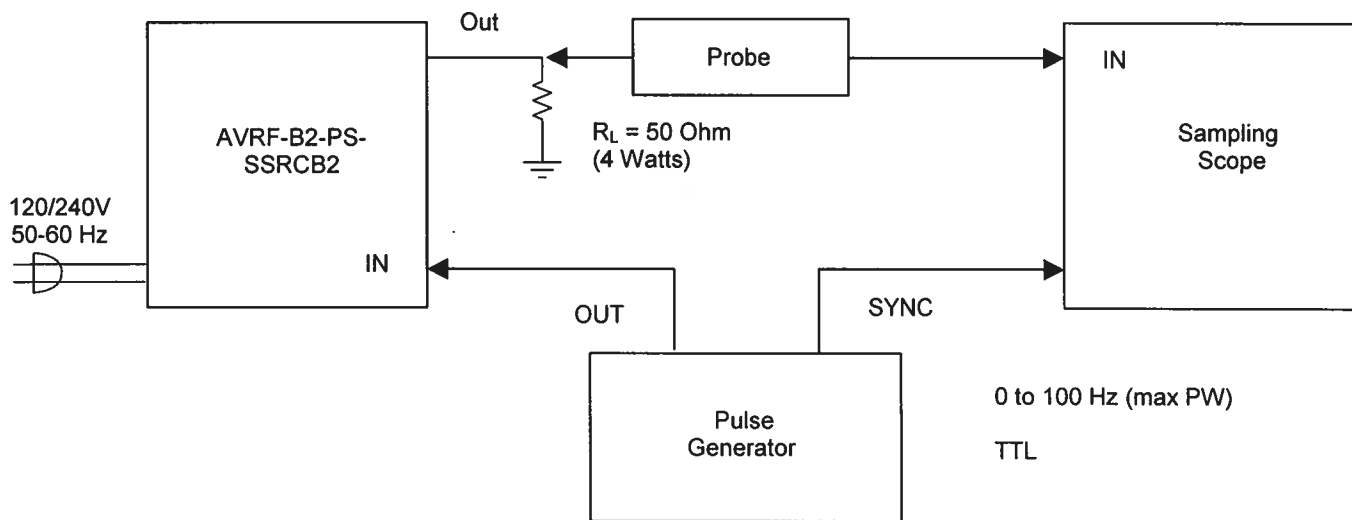
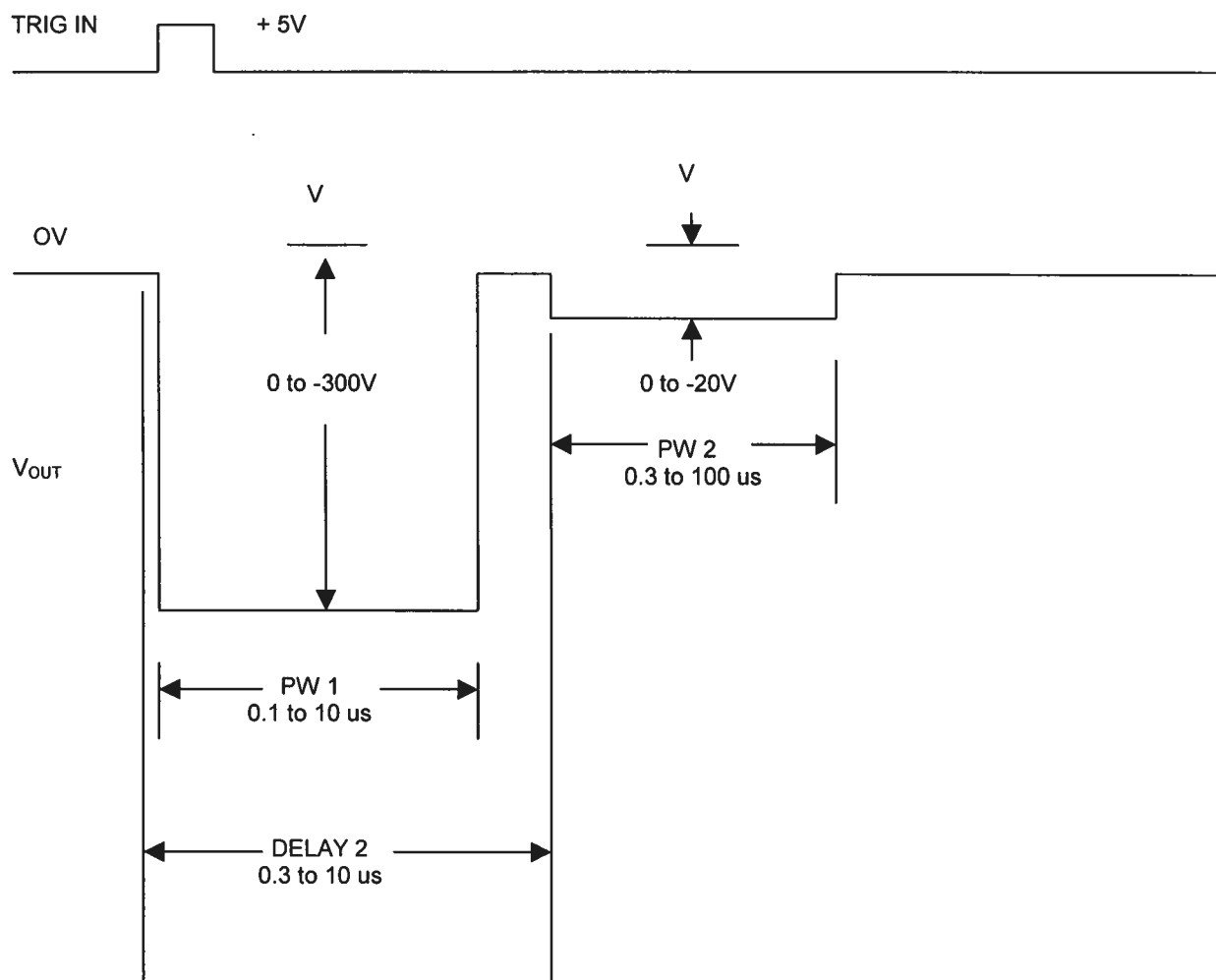

FIG. 2: OUTPUT WAVEFORM

GENERAL OPERATING INSTRUCTIONS

- 1) The bandwidth capability of components and instruments used to display the pulse generator output signal (attenuators, cables, connectors, etc.) should exceed 100 MHz.
- 2) The AVRF unit MUST be terminated in a 50 Ohm load. The 50 Ohm coax cable to the load can be of any length.
- 3) Note that if the delay A2 setting is less than the PW 1 setting, then the PW 2 will be reduced. For this reason, it may be convenient to first set the DELAY A2 control to maximum and then reduce it as required after setting PW 1.
- 4) The rear panel monitor output provides a coincident attenuated (x10) replica of the output waveform. This monitor output requires a 50 Ohm load.
- 5) OVERLOAD INDICATOR. AVRF units with a serial number higher than 5600 are protected by an automatic overload protective circuit which controls the front panel overload light. If the unit is overloaded (by operating at an exceedingly high duty cycle or by operating into a short circuit), the protective circuit will turn the output of the instrument OFF and turn the indicator light ON. The light will stay ON (i.e. output OFF) for about 5 seconds after which the instrument will attempt to turn ON (i.e. light OFF) for about 1 second. If the overload condition persists, the instrument will turn OFF again (i.e. light ON) for another 5 seconds. If the overload condition has been removed, the instrument will turn on and resume normal operation. Overload conditions may be removed by:
 - 1) Reducing PRF (i.e. switch to a lower range)
 - 2) Reducing pulse width (i.e. switch to a lower range)
 - 3) Removing output load short circuit (if any)

Note that the overload light may illuminate when the prime power is first applied. The light will extinguish after a few seconds and the instrument will then function normally.

Note that the output stage will safely withstand a short circuited load condition.

- 6) The unit can be converted from 120 to 240V 50-60 Hz operation by adjusting the voltage selector card in the rear panel fused voltage selector cable connector assembly.

7) For additional information:

Tel: (613) 226-5772

Fax: (613) 226-2802

Email: info@avtechpulse.com

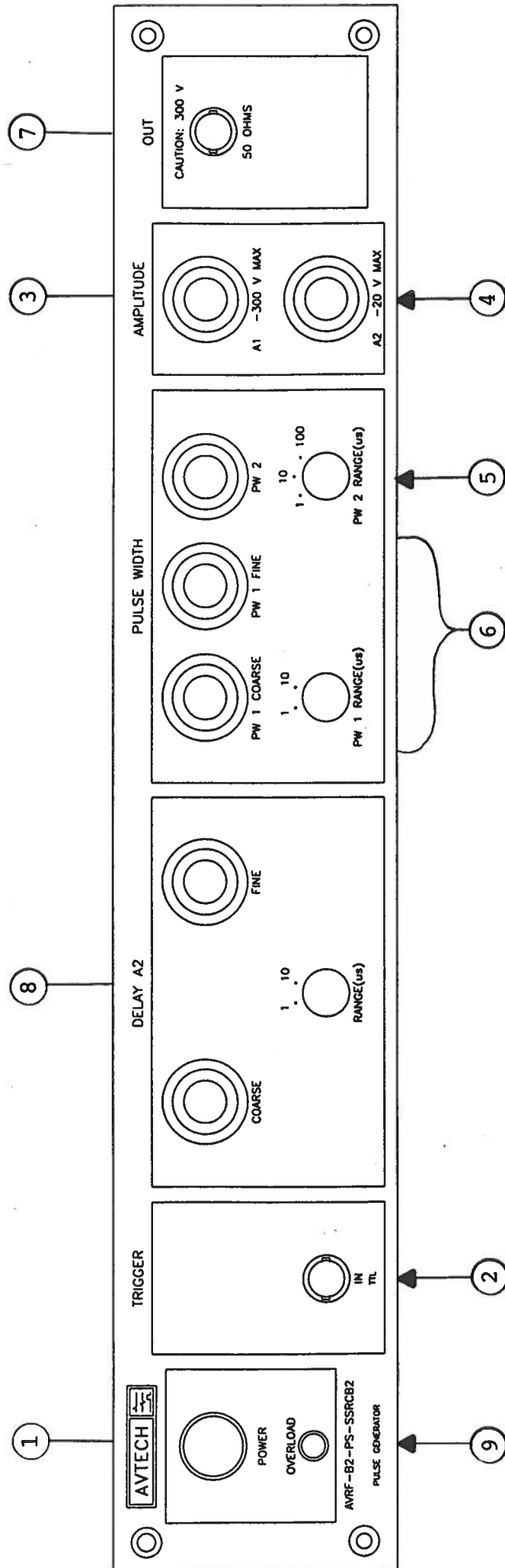

FIG. 3: FRONT PANEL CONTROLS

FRONT PANEL CONTROLS

- (1) ON-OFF Switch. Applies basic prime power to all stages.
- (2) TRIG Input. The external trigger signal is applied at this input (TTL).
- (3) AMPLITUDE A1. Ten-turn control varies the A1 amplitude from 0 to -300 Volts.
- (4) AMPLITUDE A2. Ten-turn control varies the A2 amplitude from 0 to -20 Volts.
- (5) PULSE WIDTH PW 2. Three-position range switch and a ten-turn control varies PW 2 from 0.3 to 100 us (provided DELAY A2 exceeds PW 1).
- (6) PULSE WIDTH PW 1. Two-position range switch and a ten-turn control varies PW 1 from 0.1 to 10 us.
- (7) OUT Connector. BNC connector provides output to the load ($R_L = 50 \text{ Ohm}$).
- (8) OVERLOAD INDICATOR. Units with a serial number higher than 5600 are protected by an automatic overload protective circuit which controls the front panel overload light. If the unit is overloaded (by operating at an exceedingly high duty cycle or by operating into a short circuit), the protective circuit will turn the output of the instrument OFF and turn the indicator light ON. The light will stay ON (i.e. output OFF) for about 5 seconds after which the instrument will attempt to turn ON (i.e. light OFF) for about 1 second. If the overload condition persists, the instrument will turn OFF again (i.e. light ON) for another 5 seconds. If the overload condition has been removed, the instrument will turn on and resume normal operation. Overload conditions may be removed by:
 - 1) Reducing PRF (i.e. switch to a lower range)
 - 2) Reducing pulse width (i.e. switch to a lower range)
 - 3) Removing output load short circuit (if any)

Note that the overload light may illuminate when the prime power is first applied. The light will extinguish after a few seconds and the instrument will then function normally.

Note that the output stage will safely withstand a short-circuited load condition.

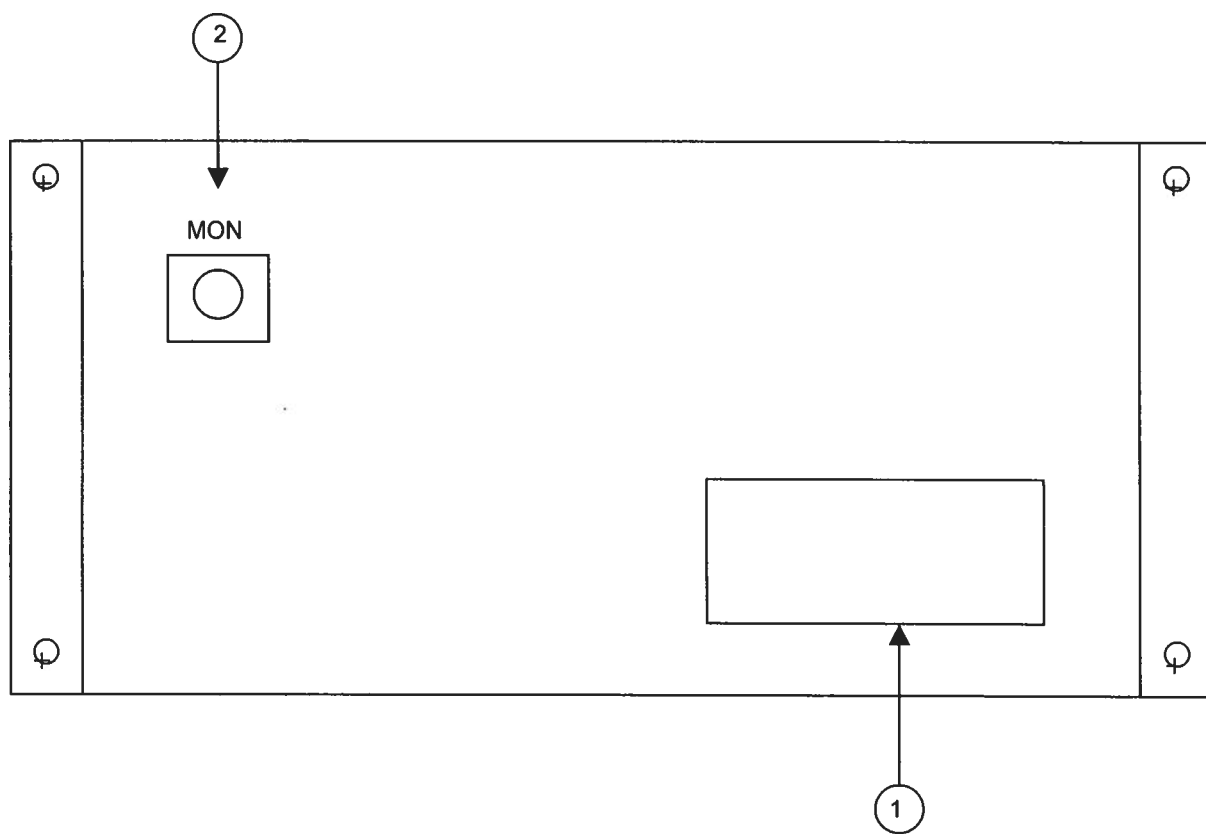
FIG. 4: BACK PANEL CONTROLS

BACK PANEL CONTROLS

- (1) FUSED CONNECTOR, VOLTAGE SELECTOR. The detachable power cord is connected at this point. In addition, the removable cord is adjusted to select the desired input operating voltage. The unit also contains the main power fuse.

For AC line voltages of 110-120V, the power selector card should be installed so that the "120" marking is visible from the rear of the instrument.

For AC line voltages of 220-240V, the power selector card should be installed so that the "240" marking is visible from the rear of the instrument.

If it is not set for the proper voltage, remove the fuse and then grasp the card with a pair of pliers and remove it. Rotate horizontally through 180 degrees. Reinstall the card and the correct fuse.

In the 120V setting, a 1.0A slow blow fuse is required. In the 240V setting, a 0.5A slow blow fuse is required.

- (2) MON. The monitor output provides an attenuated (x10) coincident replica of the output pulse. The monitor output must be terminated in 50 Ohms when in use.

TOP COVER REMOVAL AND RACK MOUNTING

- 1) The interior of the instrument may be accessed by removing the four Phillips screws on the top panel. With the four screws removed, the top cover may be slid back (and off).
- 2) The -R5 rack mount kit may be installed after first removing the one Phillips screw on the side panel adjacent to the front handle.

SYSTEM DESCRIPTION AND REPAIR PROCEDURE

In the event of an instrument malfunction, it is most likely that the power supply 1.0 A slow blow fuse or the main power fuse on the rear panel has blown. Replace if necessary. If the unit still does not function, it is most likely that some of the output switching elements (SL18T in A1 or SL28T in A2) may have failed due to an output short circuit condition or to a high duty cycle condition. The switching elements may be accessed by removing the cover plate on the bottom side of the instrument. The cover plates are removed by removing the two 2-56 Phillips screws. **NOTE:** First turn off the prime power. **CAUTION:** Briefly ground the SL18T tabs to discharge the 300 Volts power supply potential. The elements may be removed from their sockets by means of needle nosed pliers. The SL18T is a selected VMOS power transistor in a TO 220 package and may be on a curve tracer. If defective, replacement units should be ordered directly from Avtech. When replacing the SL18T switching elements, take care to insure that the short lead (of the three leads) is adjacent to the back of the chassis.

POWER SUPPLY AND FUSE REPLACEMENT

This instrument has three fuses (plus one spare). One, which protects the AC input, is located in the rear-panel power entry module, as described in the "Rear Panel Controls" section of this manual. If the power appears to have failed, check the AC fuse first.

The other two fuses (plus one spare) are located on the internal DC power supply, as shown below:

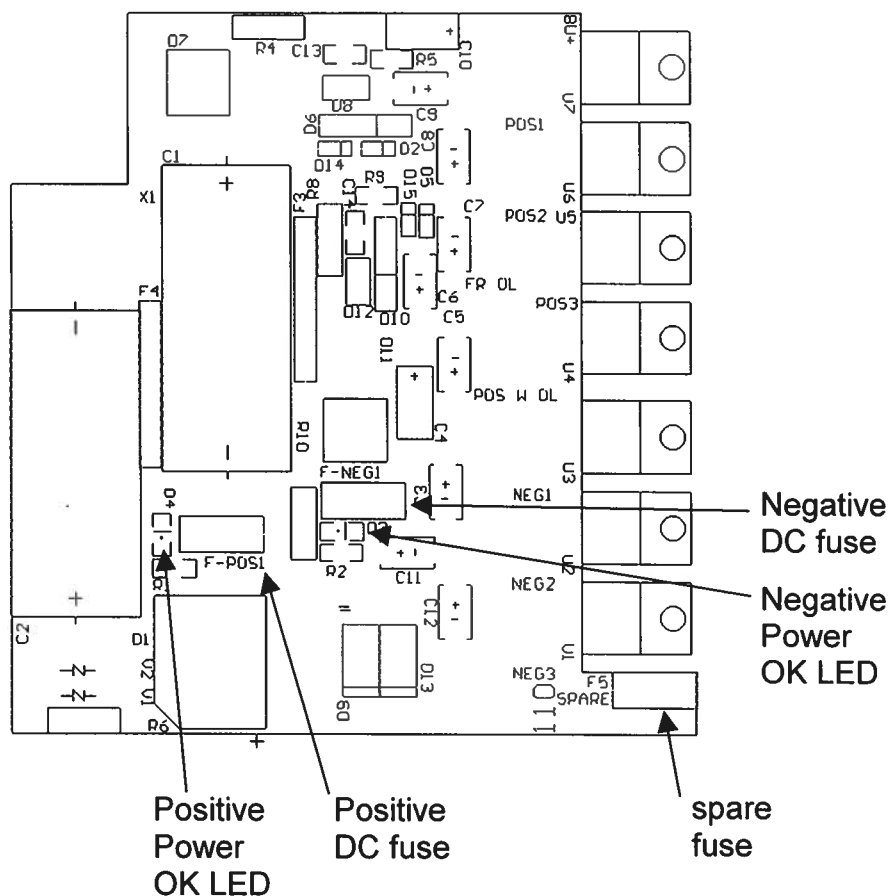

The positive fuse and the spare fuse on this circuit board are 1A slow-blow fuses, Littlefuse part number R452001. (This fuse can be ordered from Digikey, www.digikey.com. The Digikey part number is F1343CT-ND). The negative fuse is a 0.5A slow-blow fuse (Littlefuse R452.500, Digikey part number F1341CT-ND).

If you suspect that the DC fuses are blown, follow this procedure:

1. Remove the top cover, by removing the four Phillips screws on the top cover and then sliding the cover back and off.

2. Locate the two "Power OK" LEDs on the power supply circuit board, as illustrated above.
3. Turn on the instrument.
4. Observe the "Power OK" LEDs. If the fuses are not blown, the two LEDs will be lit (bright red). If one of the LEDs is not lit, the fuse next to it has blown.
5. Turn off the instrument.
6. If a fuse is blown, use needle-nose pliers to remove the blown fuse from its surface-mount holder.
7. Replace the fuse.

ORIGINAL QUOTATION

Avtech Sales

From: Sales [info@avtechpulse.com]
Sent: Friday, February 04, 2000 1:09 PM
To: 'lee@src.gov.tw'
Subject: Price and Delivery Quotation

August 10, 2000

Dear Kaidee,

1) We are pleased to quote as follows:

Quote No: 10015
Model Designation: AVRF-B2-PS-N-SRRCB2
Amplitude A1: -10 to -300 Volts (to 50 Ohms), ten-turn control
Amplitude A2: -0.2 to -20 Volts (to 50 Ohms), ten-turn control
Pulse Width W1: 0.1 to 10 us, two ten-turn controls (fine and course) and two-position decade range switch
Pulse Width W2: 0.3 to 100 us, ten-turn control and three-position decade range switch
Rise, Fall Times: </- 15 ns for both A1 and A2
Input Trigger: TTL, PW >/- 50 ns
PRF: 0 to 1 kHz
Maximum Duty Cycle: 0.1% (eg. for W1 = 10 us, PRF max 100 Hz, for W1 = 1.0 us, PRF max 1 kHz)
Propagation Delay A1: ~/- 150 ns
Propagation Delay A2: Adjustable (two ten-turn controls, (fine and course) and two-position decade range switch) to maintain leading edge in sync with falling edge of A1
Chassis Size: 5.5" x 17" x 14.8"
Prime Power: 120/240 V, 50-60 Hz
Connectors: BNC
Price: \$6,498.00 US, EXWORKS: Ottawa, Canada
Delivery: 60-90 days, after receipt of order

Regards,

Dr. Walter Chudobiak
Chief Engineer

--- Avtech Electrosystems Ltd. ----- since 1975 ---

PO Box 265 ph: 1-800-265-6681 or 613-226-5772 Box 5120 Stn. F
Ogdensburg, NY fax: 1-800-561-1970 or 613-226-2802 Ottawa, Ontario
USA 13669-0265 email: info@avtechpulse.com Canada K2C 3H4
http://www.avtechpulse.com/

Nanosecond Waveform Generators
for general purpose, R&D and OEM applications

Pulse Generators - Laser Diode Drivers - Pulse Amplifiers
Impulse Generators - Delay Generators - Comb Generators - Splitters
Function Generators - Monocycle Generators - Frequency Dividers + more!

DEC 13/2000
(ed. A)