



AVTECH ELECTROSYSTEMS LTD.

NANOSECOND WAVEFORM ELECTRONICS
SINCE 1975

P.O. BOX 265
OGDENSBURG, NY
U.S.A. 13669-0265
TEL: (315) 472-5270
FAX: (613) 226-2802

TEL: 1-800-265-6681
FAX: 1-800-561-1970
U.S.A. & CANADA

e-mail: info@avtechpulse.com

BOX 5120 STN. F
OTTAWA, ONTARIO
CANADA K2C 3H4
TEL: (613) 226-5772
FAX: (613) 226-2802

INSTRUCTIONS

MODEL AVRFB-4-PS PULSE GENERATOR

S.N. :

WARRANTY

Avtech Electrosystems Ltd. warrants products of its manufacture to be free from defects in material and workmanship under conditions of normal use. If, within one year after delivery to the original owner, and after prepaid return by the original owner, this Avtech product is found to be defective, Avtech shall at its option repair or replace said defective item. This warranty does not apply to units which have been disassembled, modified or subjected to conditions exceeding the applicable specifications or ratings. This warranty is the extent of the obligation or liability assumed by Avtech with respect to this product and no other warranty or guarantee is either expressed or implied.

GENERAL OPERATING INSTRUCTIONS

- 1) The equipment should be connected in the general fashion shown above. Since the AVRF unit provides an output pulse rise time of less than 5 ns, a fast oscilloscope (at least 200 MHz and preferably ≥ 1 GHz) should be used to display the waveform. CAUTION: This unit requires a well defined 50 Ohm load impedance. The output waveform will be distorted if the impedance differs substantially from 50 Ohms.
- 2) The output PRF is equal to the input trigger pulse PRF. CAUTION: The PRF must not exceed 1 kHz.
- 3) When the MODE A-B switch is in the A position, the output pulse width is controlled by the ten turn PW control. To voltage control the output pulse width, set the rear panel switch in the EXT position and apply 0 to +10 Volts to BNC connector "A" ($R_{IN} \geq 10K$). (option).
- 4) When the MODE A-B switch is in the B position, the output pulse width equals the input trigger pulse width. CAUTION: The pulse width must not exceed 1 us.
- 5) The output pulse amplitude is controlled by means of the front panel ten turn AMP control. To voltage control the output amplitude, set the rear panel switch in the EXT position and apply 0 to +10 Volts to BNC connector ($R_{IN} \geq 10K$). (option).
- 6) CAUTION: The maximum PRF, PW or duty cycle conditions must not be exceeded. Under simultaneous conditions of wide pulse width and high PRF, the bias voltage applied to the output power stage decreases and as a result the attainable output peak voltage decreases to less than 400 Volts. Under conditions of severe loading the output stage may be damaged. The output switching elements can be replaced following the procedure given in the following section.

A.

TEST ARRANGEMENT

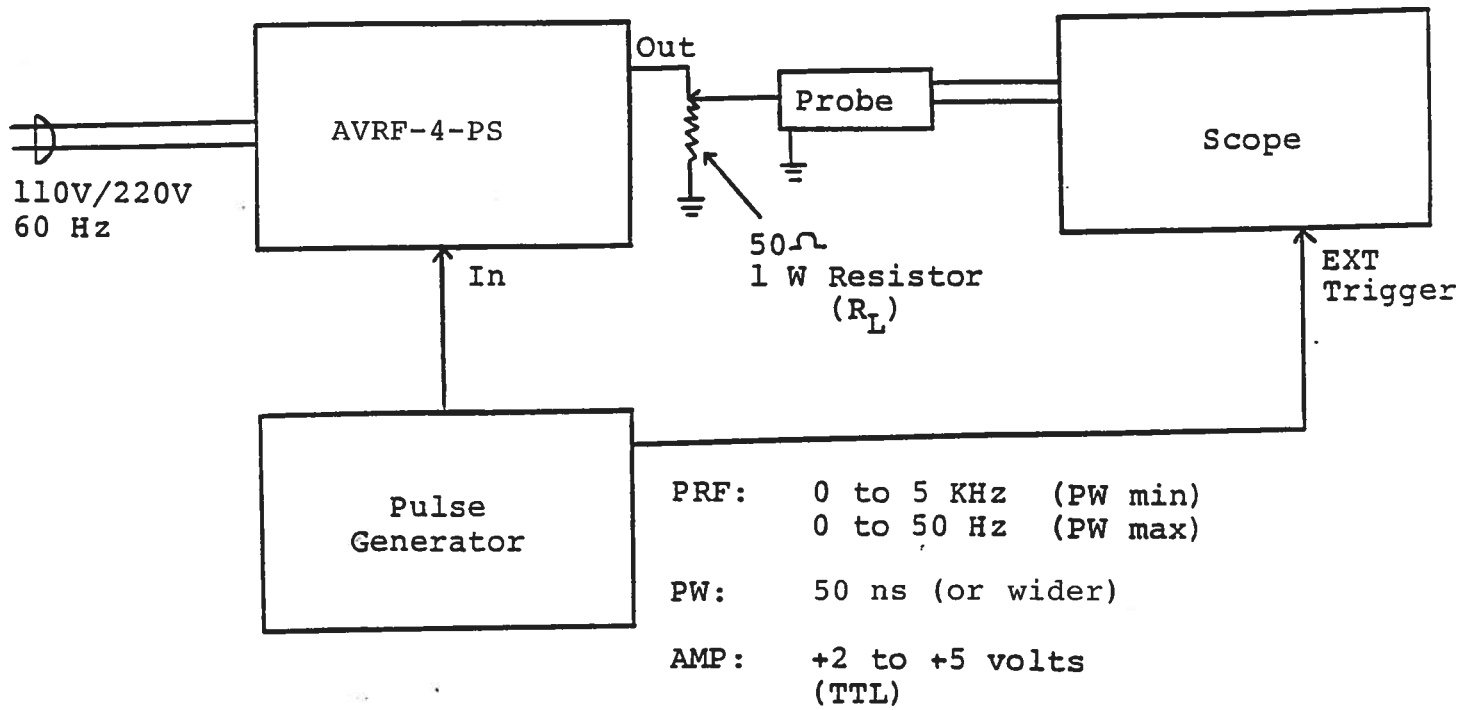

7) OVERLOAD. An automatic overload protective circuit controls the front panel overload light. If the unit is overloaded (by operating at an exceedingly high duty cycle or by operating into a very low impedance), the protective circuit will turn the output of the instrument OFF and turn the indicator light ON. The light will stay ON (i.e. output OFF) for about 5 seconds after which the instrument will attempt to turn ON (i.e. light OFF) for about 1 second. If the overload condition persists, the instrument will turn OFF again (i.e. light ON) for another 5 seconds. If the overload condition has been removed, the instrument will turn on and resume normal operation. Overload conditions may be removed by:

- 1) Reducing PRF (i.e. switch to a lower range)
- 2) Reducing pulse width (i.e. switch to a lower range)
- 3) Removing output low load impedance (if any)
- 4) Reducing the output amplitude (i.e. switch to a lower range)

The overload light may illuminate when the prime power is first applied. The light will extinguish after a few seconds and the unit will then operate normally.

Note that the output stage will safely withstand a short circuited load condition.

8) The AVRF unit can be converted from 120 to 240V 50-60 Hz operation by adjusting the voltage selector card in the rear panel fused voltage selector-cable connector assembly.

9) For additional assistance:

Tel: 613-226-5772
Fax: 613-226-2802

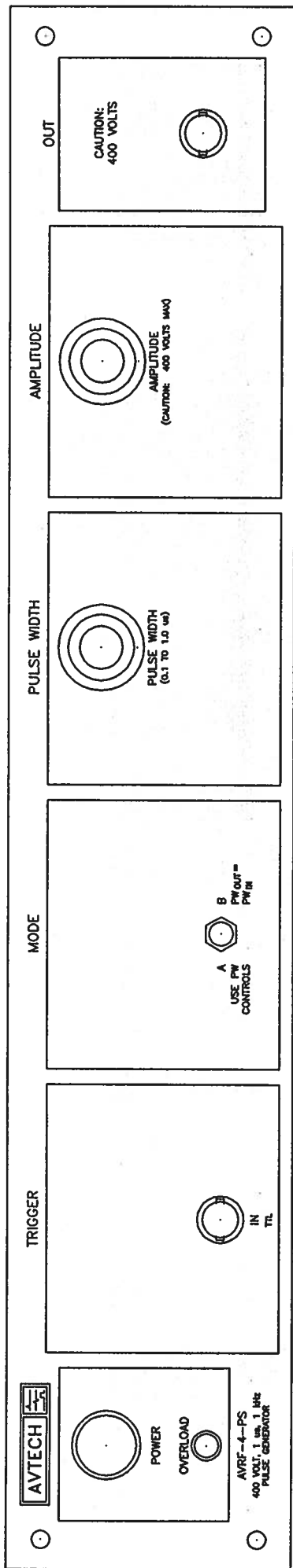

Fig. 2

FRONT PANEL CONTROLS

TOP COVER REMOVAL AND RACK MOUNTING

- 1) The interior of the instrument may be accessed by removing the four Phillips screws on the top panel. With the four screws removed, the top cover may be slid back (and off).
- 2) The -R5 rack mount kit may be installed after first removing the one Phillips screw on the side panel adjacent to the front handle.

- 1) The AVRF unit consists of five basic components or modules:
 - a) Metal chassis
 - b) AC to DC power supply board
 - c) -PG pulse generator module
 - d) -PS power supply module
 - e) -PW pulse width control module

The modules are interconnected as shown above.

- 2) If the unit malfunctions, disconnect from the 60 Hz supply and the trigger source and remove the four Phillips screws on the top panel of the unit. With the screws removed, the top cover may be slid off.
- 3) Reconnect to the 60 Hz source and check the voltage on the line connecting the AVR-PS output to the +24 V pin of the AVR-PG module. A voltage of +24 Volts should be recorded. If the voltage is substantially less than +24 Volts, disconnect the 60 Hz source and disconnect the line from the +24 Volt pin. Connect a 50 Ohm 8 Watt resistance to the output of the AVR-PS module. Reconnect to the 60 Hz source and measure the voltage across this resistor. A voltage of +24 Volts should be indicated. If the voltage is substantially less than 24 Volts the AVR-PS module is defective and should be either repaired or replaced. If the measured voltage is equal to +24 Volts then the SL19TF switching elements in the AVR-PG module have probably failed. The SL19TF switching elements are easily replaced by removing the cover plate on the instrument bottom side and extracting the SL19TF switching elements from their sockets using a pair of needle nose pliers. Before attempting this first insure that the prime power is off and also briefly ground the metal tabs on the SL19TF elements to the chassis as the bypass capacitors may be charged to 425 Volts. Replacement SL19TF units must be ordered directly from Avtech. When reinstalling the SL19TF units in their sockets, insure that the shortest of the three terminals is adjacent to the black dot on the AVR-PG chassis.