



AVTECH ELECTROSYSTEMS LTD.

NANOSECOND WAVEFORM ELECTRONICS
SINCE 1975

P.O. BOX 265
OGDENSBURG, NY
U.S.A. 13669-0265
TEL: (315) 472-5270
FAX: (613) 226-2802

TEL: 1-800-265-6681
FAX: 1-800-561-1970
U.S.A. & CANADA

BOX 5120 STN. F
OTTAWA, ONTARIO
CANADA K2C 3H4
TEL: (613) 226-5772
FAX: (613) 226-2802

INSTRUCTIONS

MODEL AVRH-3-PS-PN-AT-PWT PULSE GENERATOR

S.N.:

WARRANTY

Avtech Electrosystems Ltd. warrants products of its manufacture to be free from defects in material and workmanship under conditions of normal use. If, within one year after delivery to the original owner, and after prepaid return by the original owner, this Avtech product is found to be defective, Avtech shall at its option repair or replace said defective item. This warranty does not apply to units which have been disassembled, modified or subjected to conditions exceeding the applicable specifications or ratings. This warranty is the extent of the obligation or liability assumed by Avtech with respect to this product and no other warranty or guarantee is either expressed or implied.

Fig. 1

PULSE GENERATOR TEST ARRANGEMENT

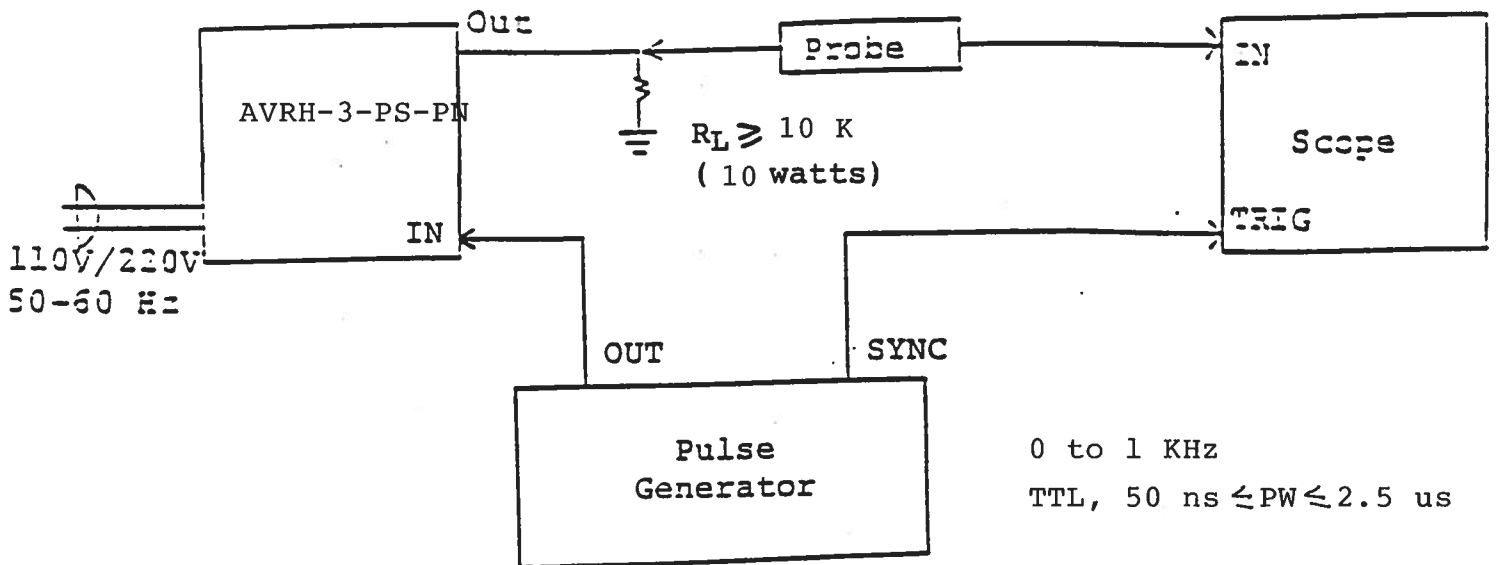

Notes:

- 1) The bandwidth capability of components and instruments used to display the pulse generator output signal (attenuators, cables, connectors, etc.) should exceed 100 MHz.
- 2) With the AB mode switch in the A position, the output pulse width is controlled by the front panel 10 turn pulse width control.
- 3) With the AB mode switch in the B position, the output pulse width is equal to the input trigger pulse width. CAUTION: The input pulse width must not exceed 2.5 us.
- 4) The output pulse amplitude is controlled by means of the front panel ten turn AMP control. CAUTION: To avoid stressing of the output stage, it is recommended that the output amplitude be turned down to zero before applying prime power to the instrument.
- 5) The output polarity is controlled by the two position polarity switch. CAUTION: To avoid stressing of the output stage it is recommended that the amplitude be reduced to near zero before changing the output polarity.
- 6) CAUTION: The output stage is protected against overload condition by a 2.0 A slow blow fuse on the main frame back panel. However, the output switching elements may fail if the unit is triggered at a PRF exceeding 1.0 kHz or at duty cycles resulting in an average output power in excess of 25 watts. Heating and subsequent likely failure of the output stage is reduced if the following action is taken where possible:
 - a) PRF is kept to a minimum, ie. operate in a low PRF range when possible rather than in a high PRF range.
 - b) Keep the output PW to a minimum.
- 7) OVERLOAD INDICATOR. AVRH units with a serial number higher than 5600 are protected by an automatic overload protective circuit which controls the front panel overload light. If the unit is overloaded (by operating at an exceedingly high duty cycle or by operating into a short circuit), the protective circuit will turn the output of the instrument OFF and turn the indicator light ON. The light will stay ON (i.e. output OFF) for about 5 seconds after which the instrument will attempt to turn ON (i.e. light OFF) for about 1 second. If the overload condition persists, the instrument will turn OFF again (i.e. light ON) for another 5 seconds. If the overload condition has been removed, the instrument will turn on and resume normal operation. Overload conditions may be removed by:

- 1) Reducing PRF (i.e. switch to a lower range)
 - 2) Reducing pulse width (i.e. switch to a lower range)
 - 3) Removing output load short circuit (if any)
- 8) Note that when the amplitude or PRF or PW are increased, the output stage of the unit will emit an audible hum. This noise is normal and is due to the step up transformer in the output stage.
- 9) CAUTION: DC potentials as high as 800 Volts and pulse potentials as high as 3000 Volts exist in the interior of the instrument. For this reason it is recommended that the top cover of the unit should not be removed and that the unit should be returned to the factory for servicing when necessary.
- 10) The unit can be converted from 110 to 220V 50-60 Hz operation by adjusting the voltage selector card in the rear panel fused voltage selector cable connector assembly.
- 11) For additional assistance:

Tel: 613-226-5772
Fax: 613-226-2802

Fig. 2: Front Panel Controls

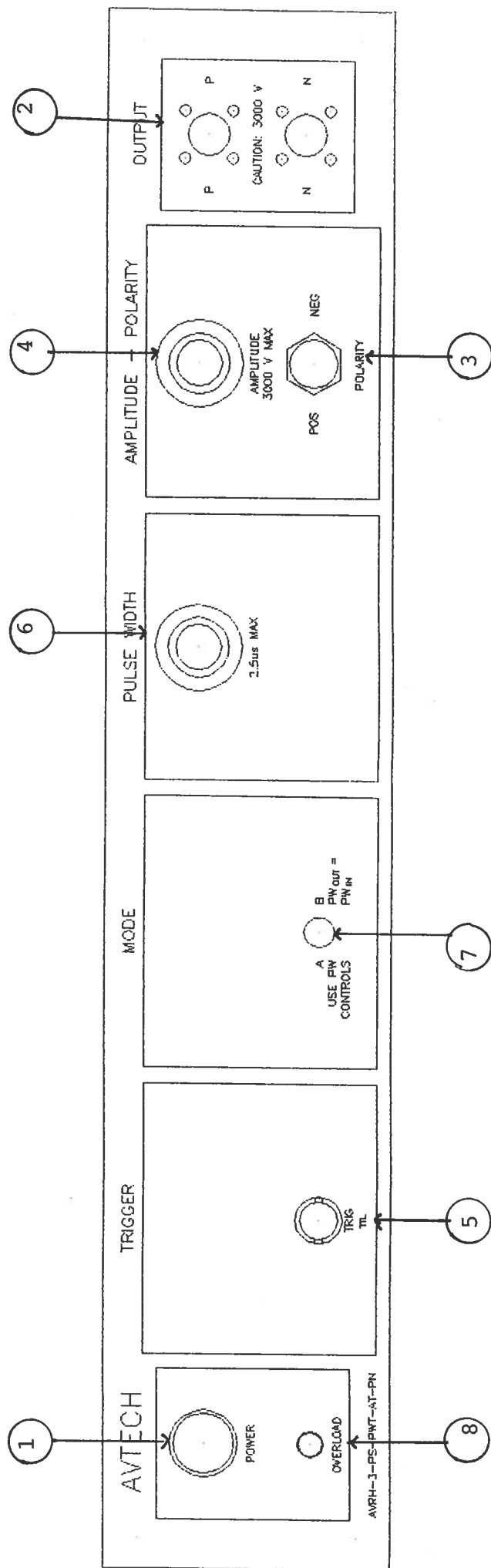

- (1) ON-OFF Switch. Applies basic prime power to all stages.
- (2) OUT Connectors. SHV connectors provide output to a high impedance load ($R_L \geq 10\text{ K}$)
- (3) POLARITY. The output pulse polarity is controlled by this two position switch. CAUTION: To avoid stressing the output stage, it is recommended that the output amplitude be reduced to near zero before changing the output polarity.
- (4) AMP Control. A ten turn control which varies the output pulse amplitude from 0 to 3000 V (to $R_L \geq 10\text{ K}$)
- (5) TRIG Input. The external trigger signal is applied at this input.
- (6) PW Control. When the MODE A-B switch is in the A position, this 10 turn control varies the output pulse width from 200 ns to 2.5 us.

	PW min	PW max
Range 1	0.1 us PRF max 10 kHz	1.0 us PRF max 5 kHz
Range 2	1.0 us PRF max 5 kHz	10 us PRF max 500 Hz
Range 3	10 us PRF max 500 Hz	100 us PRF max 50 Hz

- (7) AB MODE. When switch is in the A position output pulse width is controlled by PW control (6) while if switch is in the B position, the output pulse width equals the input trigger pulse width. CAUTION: The input pulse width must not exceed 2.5 us.
- (8) OVERLOAD INDICATOR. AVRH units with a serial number higher than 5600 are protected by an automatic overload protective circuit which controls the front panel overload light. If the unit is overloaded (by operating at an exceedingly high duty cycle or by operating into a short circuit), the protective circuit will turn the output of the instrument OFF and turn the indicator light ON. The light will stay ON (i.e. output OFF) for about 5 seconds after which the instrument will attempt to turn ON (i.e. light OFF) for about 1 second. If the overload condition persists, the instrument will turn OFF again (i.e. light ON) for another 5 seconds. If the

overload condition has been removed, the instrument will turn on and resume normal operation. Overload conditions may be removed by:

- 1) Reducing PRF (i.e. switch to a lower range)
- 2) Reducing pulse width (i.e. switch to a lower range)
- 3) Removing output load short circuit (if any)

Fig. 3

BACK PANEL CONTROLS

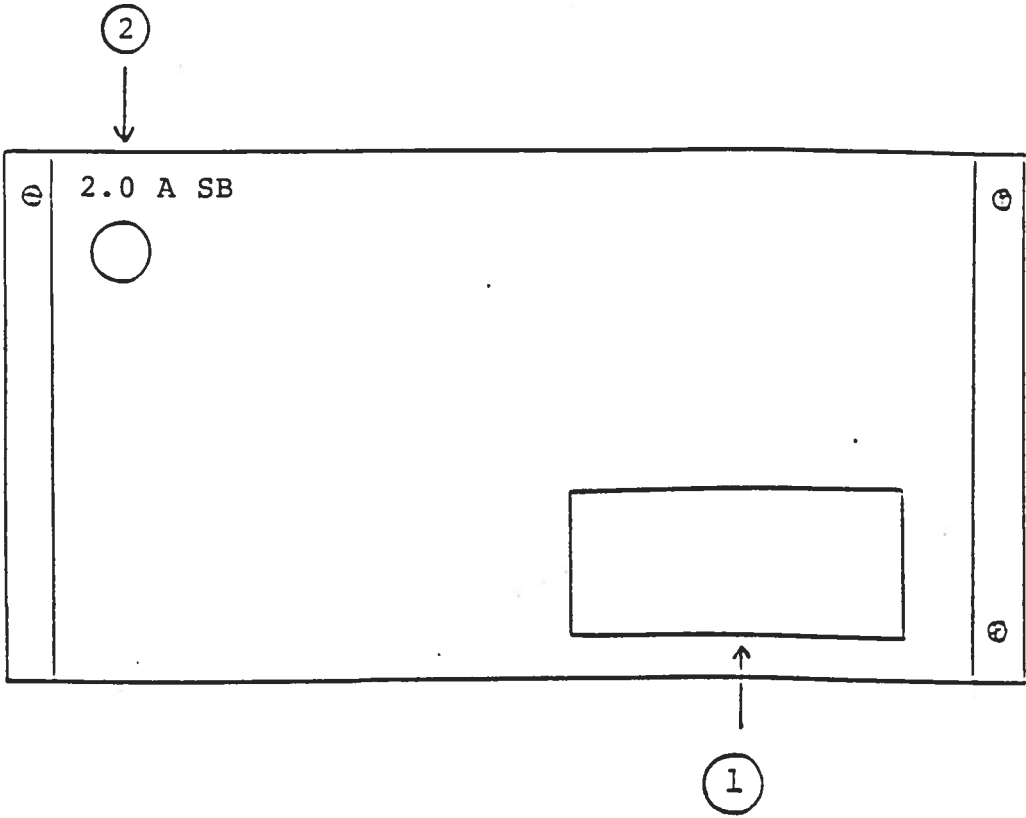

SYSTEM DESCRIPTION AND REPAIR PROCEDURE

The AVRH-3-PS generates a 3000 Volt pulse by first generating a 750 Volt pulse (of the desired width). This 750 Volt pulse is then supplied to a x4 transformer which increases the output amplitude to 3000 Volts (to $R_L > 10 \text{ K Ohms}$). DC potentials as high as 800 Volts are employed in the generation of the 750 Volt pulse so extreme caution must be employed when repairing this instrument. It is therefore highly recommended that the unit be returned to Avtech for all repairs beyond the replacement of the 0.5 Amp line fuse or the 2.0 Amp SB rear panel fuse.

POWER SUPPLY

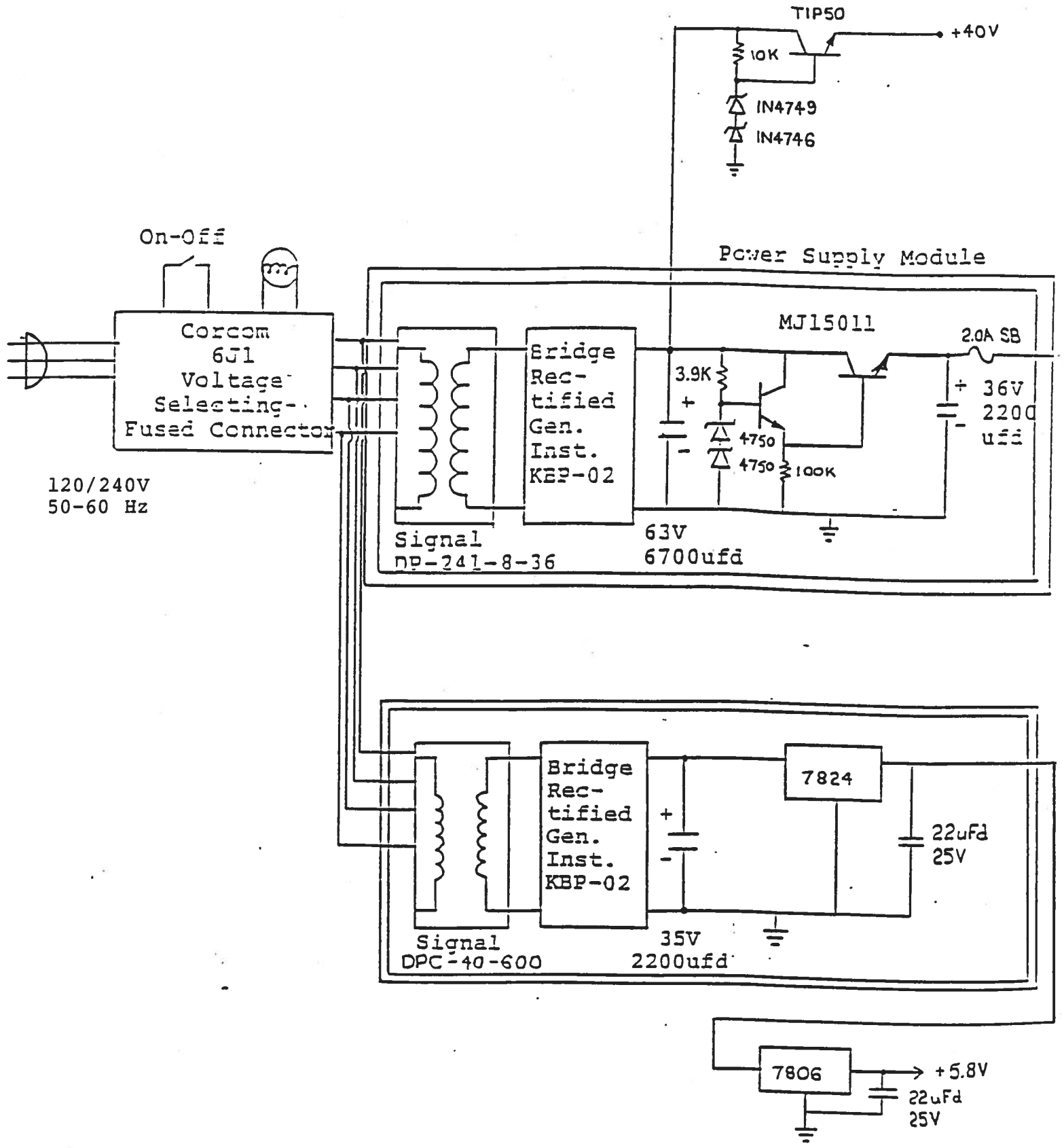

- (1) FUSED CONNECTOR, VOLTAGE SELECTOR. The detachable power cord is connected at this point. In addition, the removable cord is adjusted to select the desired input operating voltage. The unit also contains the main power fuse (0.5 A SB).
- (2) 2.0 A SB. Protects output stage against overload condition.

Aug 30/93

- (1) TESTED CONNECTOR VOLTAGE SELECTOR. The detachable power cord is connected at this point. In addition, the removable cord is adjusted to select the desired operating voltage. The unit also contains the main power fuse (0.5 A 250V).
- (2) 2.0 A DR. projects output stage against condition.
- PN
 - AT
 - PWT