



AVTECH ELECTROSYSTEMS LTD.

NANOSECOND WAVEFORM ELECTRONICS
SINCE 1975

P.O. BOX 265
OGDENSBURG, NY
U.S.A. 13669-0265
TEL: (315) 472-5270
FAX: (613) 226-2802

TEL: 1-800-265-6681
FAX: 1-800-561-1970

e-mail: info@avtechpulse.com
<http://www.avtechpulse.com>

P.O. BOX 5120 STN. F
OTTAWA, ONTARIO
CANADA K2C 3H4
TEL: (613) 226-5772
FAX: (613) 226-2802

INSTRUCTIONS

MODEL AVRL-5-PS-AS1 PULSE GENERATOR

S.N.:

WARRANTY

Avtech Electrosystems Ltd. warrants products of its manufacture to be free from defects in material and workmanship under conditions of normal use. If, within one year after delivery to the original owner, and after prepaid return by the original owner, this Avtech product is found to be defective, Avtech shall at its option repair or replace said defective item. This warranty does not apply to units which have been disassembled, modified or subjected to conditions exceeding the applicable specifications or ratings. This warranty is the extent of the obligation assumed by Avtech with respect to this product and no other warranty or guarantee is either expressed or implied.

TECHNICAL SUPPORT

Phone: 613-226-5772 or 1-800-265-6681

Fax: 613-226-2802 or 1-800-561-1970

E-mail: info@avtechpulse.com

World Wide Web: <http://www.avtechpulse.com>

TABLE OF CONTENTS

WARRANTY.....	2
TABLE OF CONTENTS	3
FIG. 1: PULSE GENERATOR TEST ARRANGEMENT.....	4
GENERAL OPERATING INSTRUCTIONS	5
FIG. 2: FRONT PANEL CONTROLS	8
FRONT PANEL CONTROLS	9
FIG. 3: BACK PANEL CONTROLS.....	10
BACK PANEL CONTROLS.....	11
POWER SUPPLY AND FUSE REPLACEMENT.....	12
PERFORMANCE CHECK SHEET	14

FIG. 1: PULSE GENERATOR TEST ARRANGEMENT

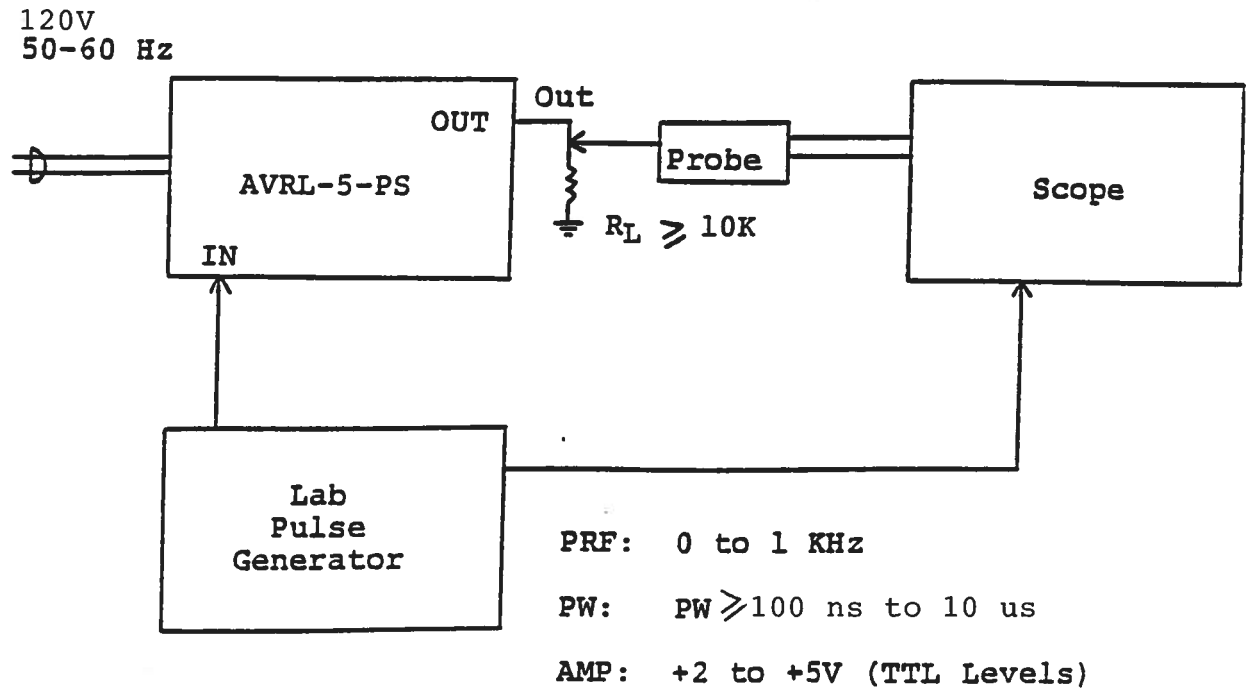

GENERAL OPERATING INSTRUCTIONS

- 1) The equipment should be connected in the general fashion shown above. A scope with a bandwidth of at least 50 MHz should be used to view the output.
- 2) The output amplitude is variable from 0 to -220 Volts. Care should be taken to insure that the scope, the load resistor and any attenuators used can withstand this high voltage.
- 3) The output pulse width equals the input trigger pulse width.
- 4) The output PRF is equal to the input PRF applied to the IN port.
- 5) The output is designed to operate directly into a high impedance load (10 K or higher). **WARNING:** The unit may fail if operated into a 50 Ohm load. The following arrangement is recommended when the output is used to pulse a biased high impedance load:

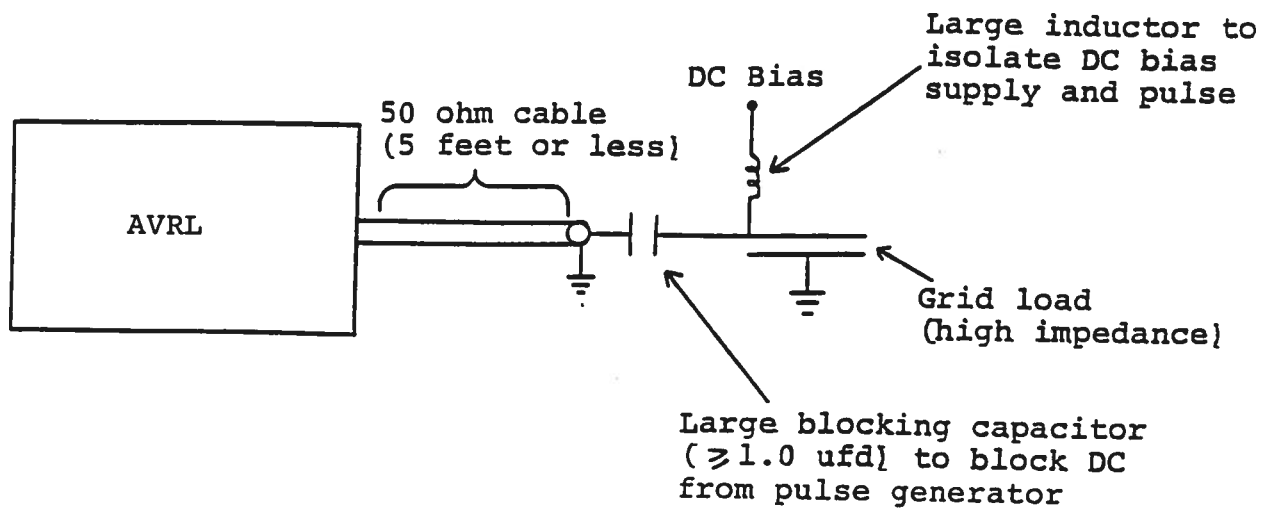

6) AVRL units with a serial number higher than 5600 are protected by an automatic overload protective circuit which controls the front panel overload light. If the unit is overloaded (by operating at an exceedingly high duty cycle or by operating into a short circuit), the protective circuit will turn the output of the instrument OFF and turn the indicator light ON. The light will stay ON (i.e. output OFF) for about 5 seconds after which the instrument will attempt to turn ON (i.e. light OFF) for about 1 second. If the overload condition persists, the instrument will turn OFF again (i.e. light ON) for another 5 seconds. If the overload condition has been removed, the instrument will turn on and resume normal operation. Overload conditions may be removed by:

- 1) Reducing PRF (i.e. switch to a lower range)
- 2) Reducing pulse width (i.e. switch to a lower range)
- 3) Removing output load short circuit (if any)

7) The unit can be converted from 120 to 240V 50-60 Hz operation by adjusting the voltage selector card in the rear panel fused voltage selector-cable connector assembly.

8) For additional assistance:

Tel: (613) 226-5772

Fax: (613) 226-2802

Email: info@avtechpulse.com

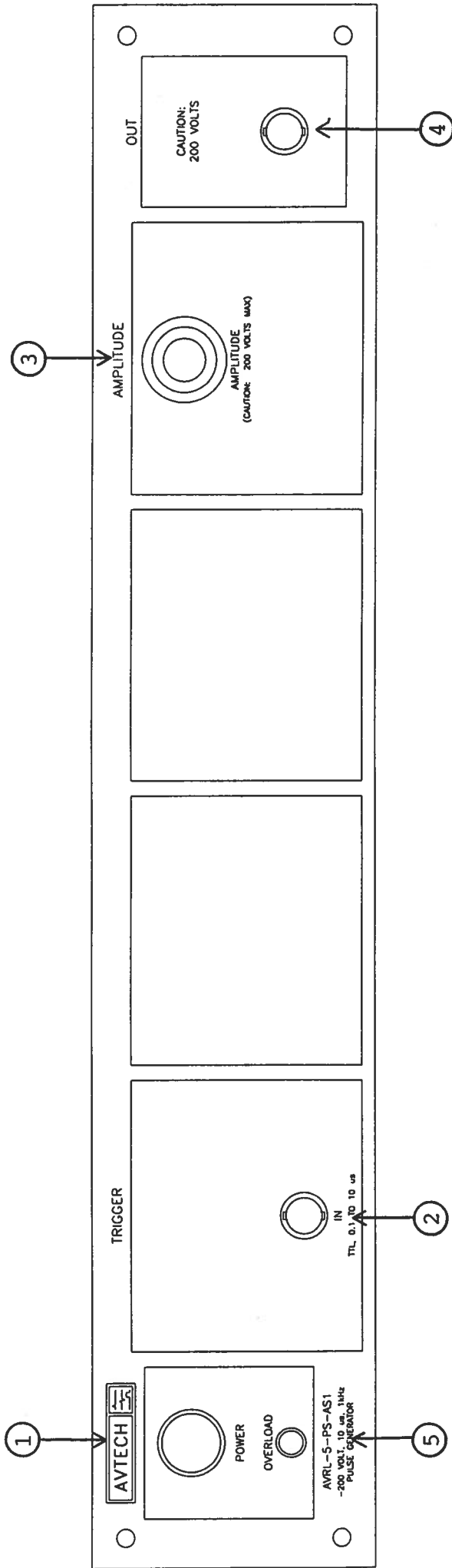
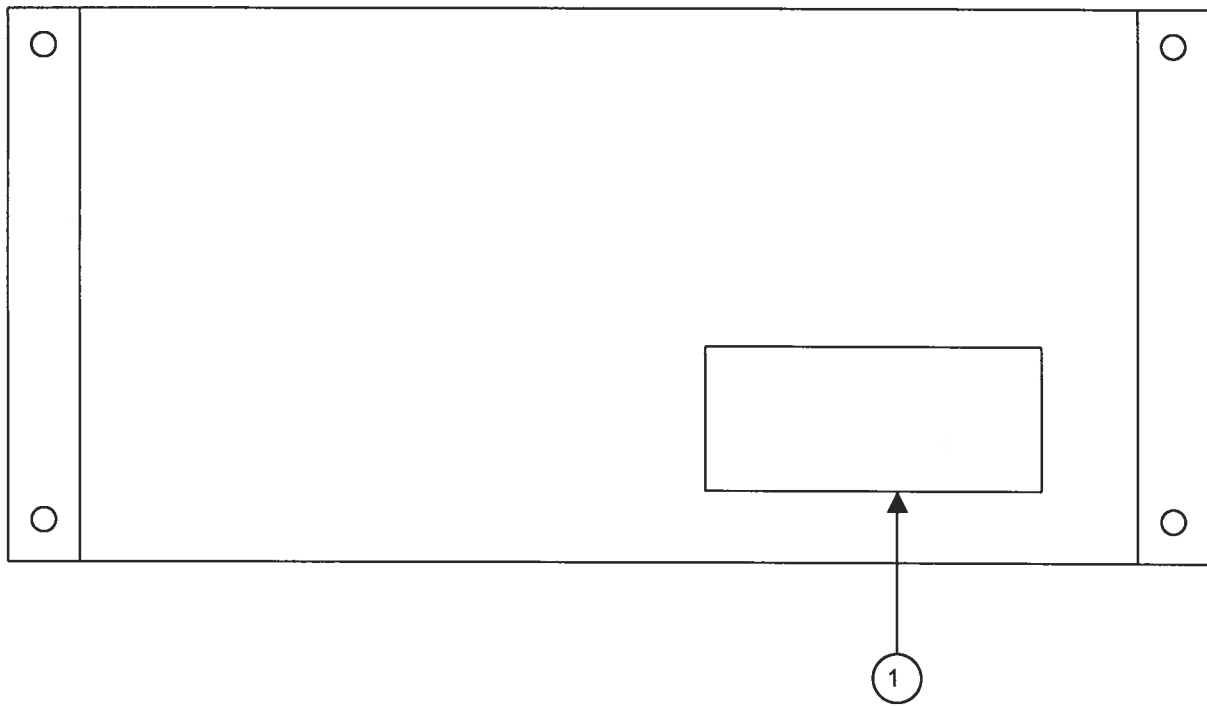

FIG. 2: FRONT PANEL CONTROLS

FRONT PANEL CONTROLS

- (1) ON-OFF Switch. Applies prime power to all stages.
- (2) IN. Input trigger applied here (+5 Volts, 100 ns to 10 us).
- (3) AMPLITUDE. A ten-turn control varies the output amplitude from 0 to –220 Volts.
- (4) OUT Connector. BNC connector used to connect output to a high impedance load (> 10K).
- (5) OVERLOAD INDICATOR. AVRL units with a serial number higher than 5600 are protected by an automatic overload protective circuit which controls the front panel overload light. If the unit is overloaded (by operating at an exceedingly high duty cycle or by operating into a short circuit), the protective circuit will turn the output of the instrument OFF and turn the indicator light ON. The light will stay ON (i.e. output OFF) for about 5 seconds after which the instrument will attempt to turn ON (i.e. light OFF) for about 1 second. If the overload condition persists, the instrument will turn OFF again (i.e. light ON) for another 5 seconds. If the overload condition has been removed, the instrument will turn on and resume normal operation. Overload conditions may be removed by:
 - 1) Reducing PRF (i.e. switch to a lower range)
 - 2) Reducing pulse width (i.e. switch to a lower range)
 - 3) Removing output load short circuit (if any)

FIG. 3: BACK PANEL CONTROLS



BACK PANEL CONTROLS

- (1) FUSED CONNECTOR, VOLTAGE SELECTOR. The detachable power cord is connected at this point. In addition, the removable cord is adjusted to select the desired input operating voltage. The unit also contains the main power fuse (0.5 A SB).

POWER SUPPLY AND FUSE REPLACEMENT

This instrument has three fuses (plus one spare). One, which protects the AC input, is located in the rear-panel power entry module, as described in the “Rear Panel Controls” section of this manual. If the power appears to have failed, check the AC fuse first.

The other two fuses (plus one spare) are located on the internal DC power supply, as shown below:

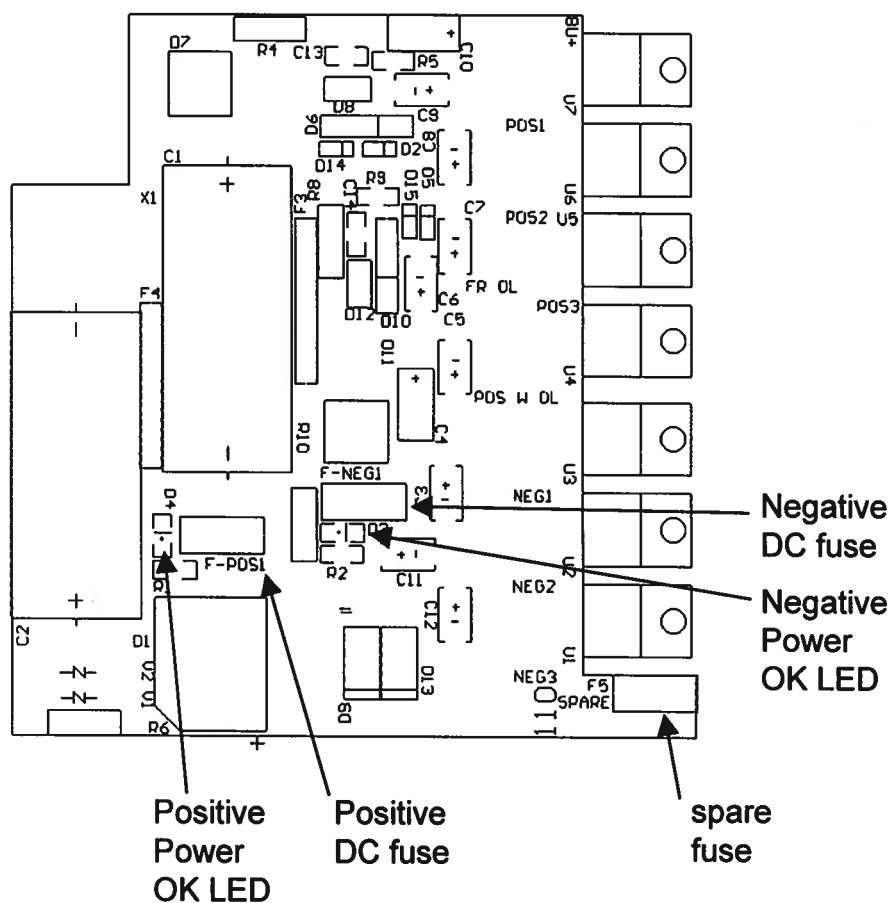

The spare fuse may be used to replace one of the other fuses, if required.

The three fuses on this circuit board are 0.5A slow-blow fuses, Littlefuse part number R452.500. (This fuse can be ordered from Digikey, www.digikey.com. The Digikey part number is F1341CT-ND).

If you suspect that the DC fuses are blown, follow this procedure:

1. Remove the top cover, by removing the four Phillips screws on the top cover and then sliding the cover back and off.
2. Locate the two "Power OK" LEDs on the power supply circuit board, as illustrated above.
3. Turn on the instrument.
4. Observe the "Power OK" LEDs. If the fuses are not blown, the two LEDs will be lit (bright red). If one of the LEDs is not lit, the fuse next to it has blown.
5. Turn off the instrument.
6. If a fuse is blown, use needle-nose pliers to remove the blown fuse from its surface-mount holder.
7. Replace the fuse.



AVTECH ELECTROSYSTEMS LTD.

NANOSECOND WAVEFORM ELECTRONICS
SINCE 1975

P.O. BOX 265
OGDENSBURG, NY
U.S.A. 13669-0265
TEL: (315) 472-5270
FAX: (613) 226-2802

TEL: 1-800-265-6681
FAX: 1-800-561-1970

e-mail: info@avtechpulse.com
<http://www.avtechpulse.com>

P.O. BOX 5120 STN. F
OTTAWA, ONTARIO
CANADA K2C 3H4
TEL: (613) 226-5772
FAX: (613) 226-2802

Fax No:	<u>4536</u>	Sender's Fax:	<u>613-226-2802</u>
File:	<u>Q:\office\QUOTES\Q9578.doc</u>	Receiver's Fax:	<u>301-805-3249</u>
To:	<u>Allied Signal</u>	Receiver's Phone:	<u>301-805-3772</u>
		Date:	<u>October 19, 1999</u>
Attn:	<u>Michael Selden</u>	Number of pages:	<u>4, including cover</u>
Subject:	<u>Price and delivery quotation</u>		

Following our telephone conversation of October 19 1999, I am pleased to quote as follows:

Quote Number:	9578
Model Designation:	AVRL-5-PS-AS1
Output Amplitude:	0 to -220 Volts To $R_L \geq 10 K$ Ten turn control
Output Pulse Width:	100 ns to 10 us. Output pulse width equals input trigger pulse width
Rise, Fall Time:	≤ 20 ns
Input Trigger:	TTL $P_{w_{OUT}}$ equals $P_{w_{IN}}$
Propagation Delay:	≤ 125 ns (fixed)
Source Impedance:	50 Ohms
Connectors:	BNC
Prime Power:	110/220 V, 50-60 Hz (switchable)
Chassis Size:	3.9" x 17" X 14.8" Includes 19" rack mount kit (-R5)
Other:	See standard AVRL-5-PS, pages 50 & 51, Cat. No. 10.
Price:	\$3,498.00 US, FOB destination.
Delivery:	45 days, after receipt of order.

Thank you for your continuing interest in our products. Please call me again if you require any further information or modifications to the above quotation.

Regards,

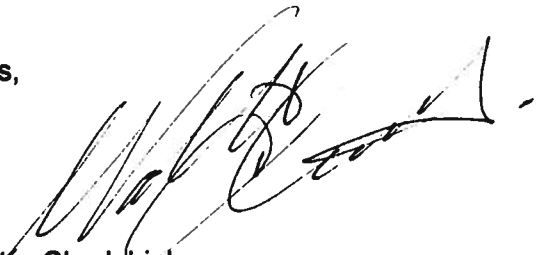
A handwritten signature in black ink, appearing to read 'Walter Chudobiak', written in a cursive style.

Dr. Walter Chudobiak
Chief Engineer

WC:mf
Encl.