

AVTECH

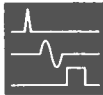

AVTECH ELECTROSYSTEMS LTD.
NANOSECOND WAVEFORM ELECTRONICS

P.O. BOX 265
OGDENSBURG, NY
U.S.A. 13669-0265
TEL: (315) 472-5270
FAX: (613) 226-2802

BOX 5120 STN. F
OTTAWA, ONTARIO
CANADA K2C 3H4
TEL: (613) 226-5772
FAX: (613) 226-2802

INSTRUCTIONS

MODEL AVRL-6-PS-D4 PULSE GENERATOR

S.N. :

WARRANTY

Avtech Electrosystems Ltd. warrants products of its manufacture to be free from defects in material and workmanship under conditions of normal use. If, within one year after delivery to the original owner, and after prepaid return by the original owner, this Avtech product is found to be defective, Avtech shall at its option repair or replace said defective item. This warranty does not apply to units which have been disassembled, modified or subjected to conditions exceeding the applicable specifications or ratings. This warranty is the extent of the obligation or liability assumed by Avtech with respect to this product and no other warranty or guarantee is either expressed or implied.

TEST ARRANGEMENT

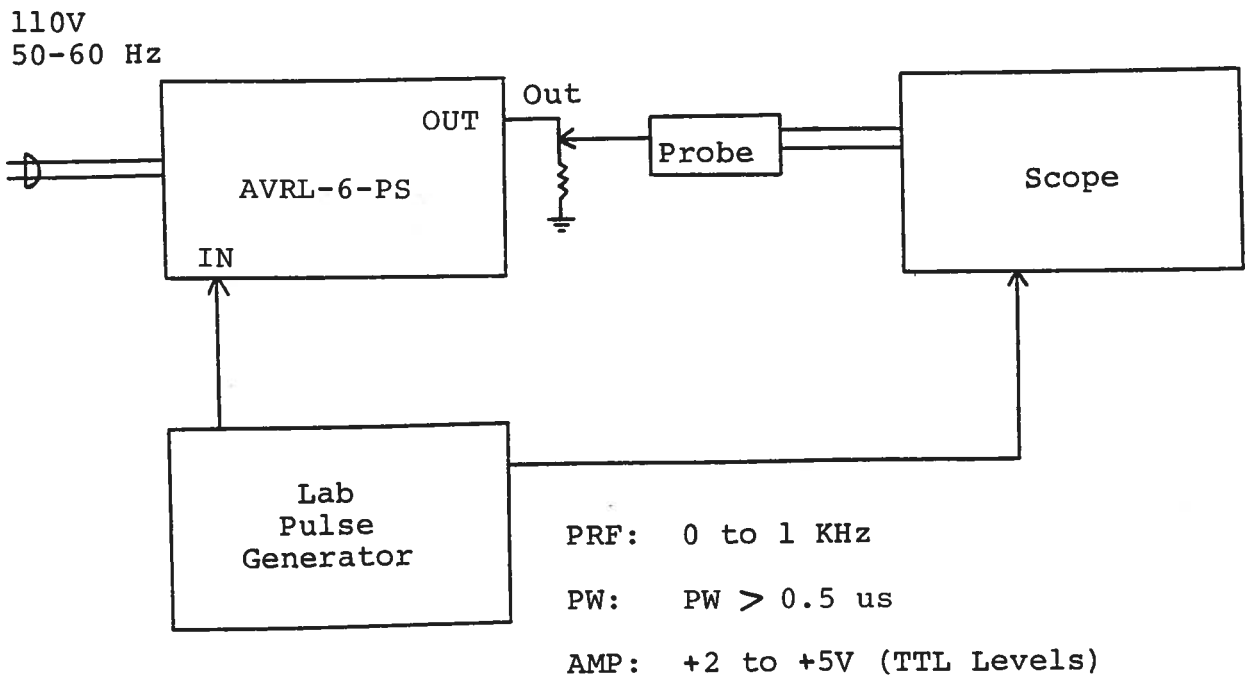

Notes:

- 1) The equipment should be connected in the general fashion shown above. A scope with a bandwidth of at least 50 MHz should be used to view output B while a scope bandwidth of at least 500 MHz is required for viewing output A.
- 2) Both output amplitudes are fixed at -200 volts. Care should be taken to insure that the scope, the load resistor and any attenuators used can withstand this high voltage.
- 3) The output pulse width for output A is variable from 5 ns to 100 ns. The output pulse width for output B is variable from 100 ns to 1 ms using the front panel PW B controls.
- 4) The output PRF is equal to the input PRF applied to the IN port. Outputs A and B will operate safely to PRF as high as 1 kHz. Note that both A and B outputs may fail if above PRF specifications are exceeded.
- 5) The propagation delay for both A and B outputs is variable from 100 ns to 100 us using the DELAY controls.
- 6) Output A is designed to operate into a fifty ohm load. The following arrangement is recommended when the AVRL unit is used to pulse a biased high impedance load (A out):

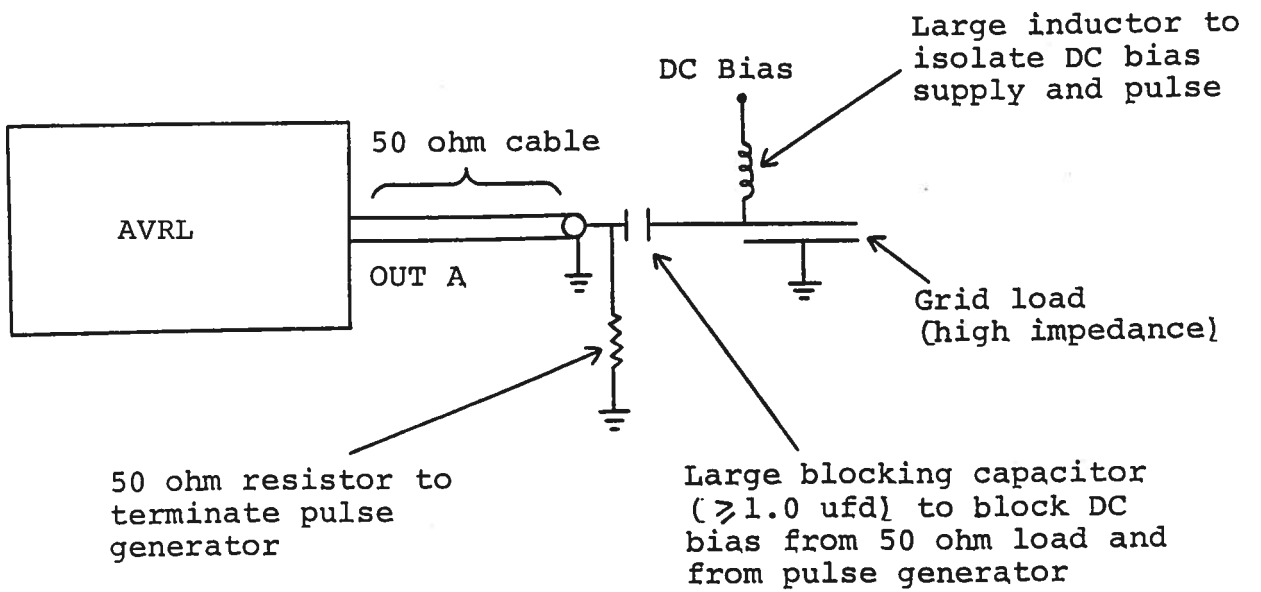

- 7) Output B is designed to operate directly into a high impedance load (10 K or higher). WARNING: Output B may fail if operated into a 50 ohm load. The following arrangement is recommended when the B output is used to pulse a biased high impedance load:

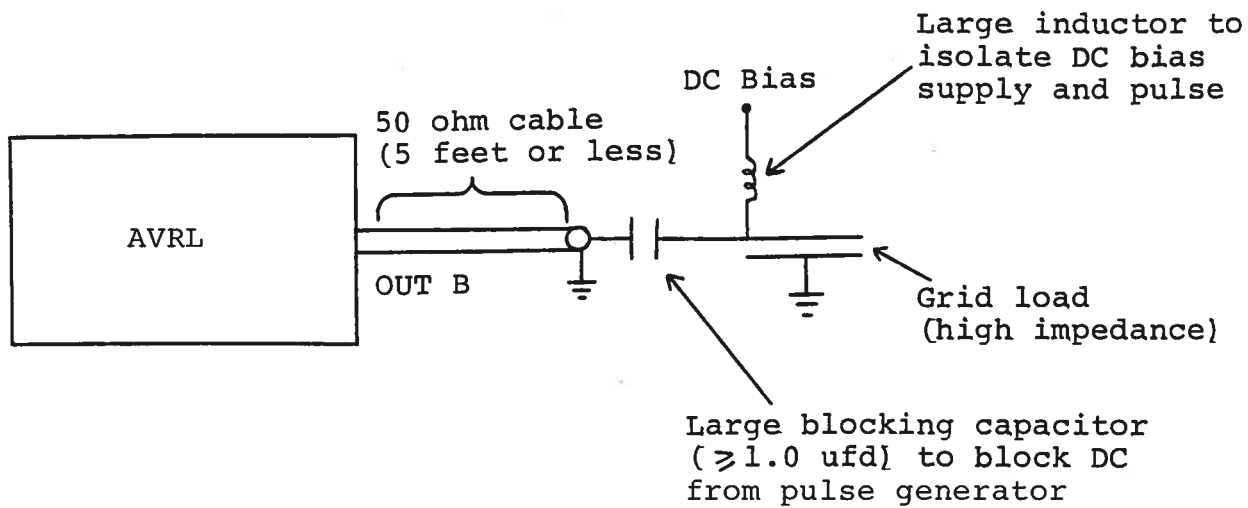

8) The output switching elements in output B may fail if the output of the unit is accidentally short-circuited or if the unit is operated at high output pulse width - high PRF combinations. The switching elements are easily replaced following the instructions given in the REPAIR Section. The output switching elements in output A are also easily replaced.

9) AVRL units with a serial number higher than 5600 are protected by an automatic overload protective circuit which controls the front panel overload light. If the unit is overloaded (by operating at an exceedingly high duty cycle or by operating into a short circuit), the protective circuit will turn the output of the instrument OFF and turn the indicator light ON. The light will stay ON (i.e. output OFF) for about 5 seconds after which the instrument will attempt to turn ON (i.e. light OFF) for about 1 second. If the overload condition persists, the instrument will turn OFF again (i.e. light ON) for another 5 seconds. If the overload condition has been removed, the instrument will turn on and resume normal operation. Overload conditions may be removed by:

- 1) Reducing PRF (i.e. switch to a lower range)
- 2) Reducing pulse width (i.e. switch to a lower range)
- 3) Removing output load short circuit (if any)

10) For additional assistance:

Tel: (613) 226-5772
Fax: (613) 226-2802

FRONT PANEL CONTROLS

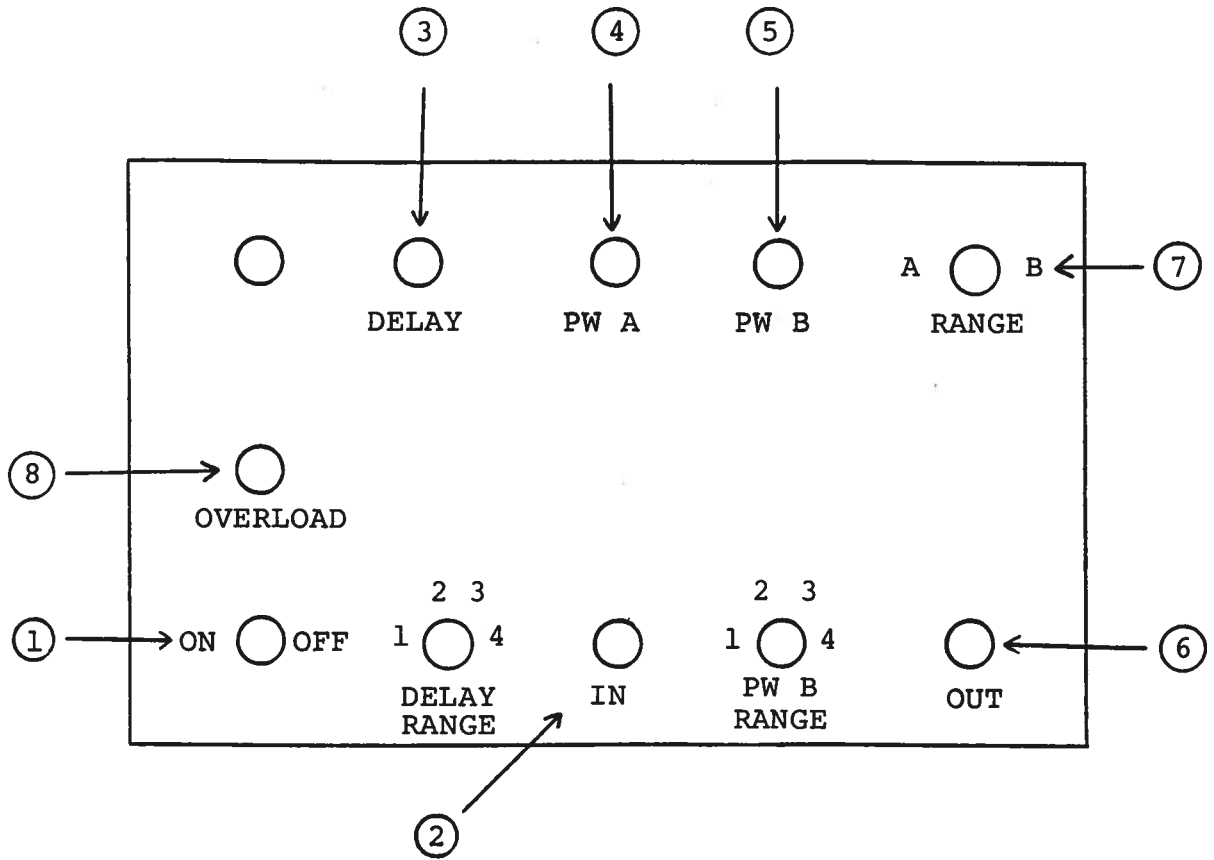

- (1) ON-OFF Switch. Applies prime power to all stages.
- (2) IN. Input trigger applied here (+5 Volts, 0.5 us or wider).
- (3) DELAY. Four position range switch and ten turn pot vary propagation delay as follows:
 - 1) 100 ns to 200 ns
 - 2) 200 ns to 1 us
 - 3) 1 us to 10 us
 - 4) 10 us to 100 us
- (4) PW_A. Ten turn control varies A out PW from 5 ns to 100 ns.
- (5) PW_B. Four position range switch and ten turn pot vary B out PW as follows:
 - 1) 100 ns to 1 us
 - 2) 1 us to 10 us
 - 3) 10 us to 100 us
 - 4) 100 us to 1 ms
- (6) OUT Connector. BNC connector used to connect output of A to 50 ohm load and output of B to high impedance load.
- (7) A-B OUTPUT Switch. With switch in the A position, pulse generator A is connected to the output connector (6) and the B pulse generator is disabled. With switch in the B position, pulse generator B is connected to the output connector (6) and the A pulse generator is disabled.
- (8) OVERLOAD INDICATOR. AVRL units with a serial number higher than 5600 are protected by an automatic overload protective circuit which controls the front panel overload light. If the unit is overloaded (by operating at an exceedingly high duty cycle or by operating into a short circuit), the protective circuit will turn the output of the instrument OFF and turn the indicator light ON. The light will stay ON (i.e. output OFF) for about 5 seconds after which the instrument will attempt to turn ON (i.e. light OFF) for about 1 second. If the overload condition persists, the instrument will turn OFF again (i.e. light ON) for another 5 seconds. If the overload condition has been removed, the instrument will turn on and resume normal operation. Overload conditions may be removed by:
 - 1) Reducing PRF (i.e. switch to a lower range)
 - 2) Reducing pulse width (i.e. switch to a lower range)
 - 3) Removing output load short circuit (if any)

BACK PANEL CONTROLS

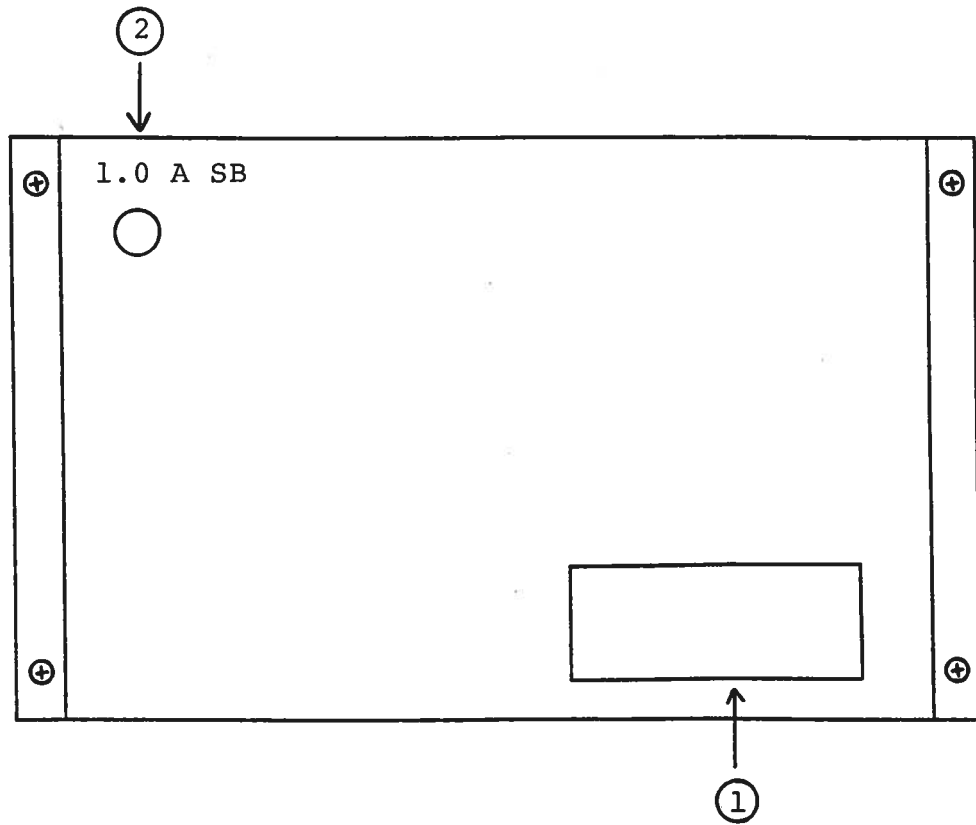

- (1) FUSED CONNECTOR, VOLTAGE SELECTOR. The detachable power cord is connected at this point. In addition, the removable cord is adjusted to select the desired input operating voltage. The unit also contains the main power fuse (0.25 A SB).
- (2) 1.0A SB. Fuse which protects the output stage if the output duty cycle rating is exceeded.

REPAIR PROCEDURE

- 1) **WARNING:** Before attempting any repairs, note that potentials as high as 400 volts are employed in the chassis structure.

- 2) The pulse generator is constructed from the following subsystems or modules:
 - a) Metal chassis
 - b) A pulse generator module (AVRL-PGA)
 - c) Delay line module (AVRL-6-DLA)
 - d) Timing module (AVRL-TNA)
 - e) Power supply modules (PS-15, AVRL-PSA, AVRL-PSB)
 - f) B pulse generator module (AVRL-PGB)
 - g) -PWB module (AVRL-PWB-D4)
 - h) +24V power supply board
 - i) Overload module (AVRL-OL)

The modules are interconnected as shown in the following diagram.

- 3) If no output is provided by the A output, turn off the prime power and remove the four Phillips screws on the back panel. The top cover may then be slid off. Turn on the prime power and apply a scope probe or voltmeter to the outer case of either of the SL3 switching elements. A voltage of about +360 volts should be indicated. If the voltage is substantially less than 360V then one of the switching elements has probably failed. Turn off the prime power and remove one of the transistors by removing the two 2-56 screws which secure the transistor in its socket. Pull the transistor out of the socket. With the unit un-triggered, turn on the prime power supply and measure the voltage from the case of the remaining transistor to ground. If this voltage is about 310 volts then the transistor which was removed is defective and should be replaced. If the voltage which is measured is less than 360 volts then the transistor still in position is defective and should be replaced. Note that the two transistors are completely interchangeable (Order Avtech Part No. SL3).

- 4) If no output is provided by the B output, then it is most likely that the SL22T switching elements in the B output stage have been damaged and should be replaced. Turn off the prime power and remove the instrument bottom panel cover plate thereby exposing the SL4 switching elements. The SL22T elements may be removed from their sockets using a pair of needle nosed pliers. Before attempting this, first insure that the prime power is off and also briefly ground the metal tabs on

the SL22T elements to the chassis as the bypass capacitors may be charged to -220 volts. Replacement SL22T units must be ordered directly from Avtech. When reinstalling the SL22T units in their sockets, insure that the shortest of the three terminals is adjacent to the black dot on the AVRL chassis.

+24 VOLT POWER SUPPLY

The AVRL-6 consists of the seven standard modules and a power supply board which supplies +24 volts (600 mA max) to the modules. In the event that the unit malfunctions, remove the instrument top cover, thereby exposing the modules. Measure the voltage at the +24 V pin of the PS module. If this voltage is substantially less than +24 volts, unsolder the line connecting the power supply board output and connect a 50 ohm 10 W load to the power supply output. The voltage across this load should be about +24 V DC. If this voltage is substantially less than 24 volts the power supply board is defective and should be repaired or replaced. If the voltage is near +24V then see instructions in preceding section.

POWER SUPPLY BOARD

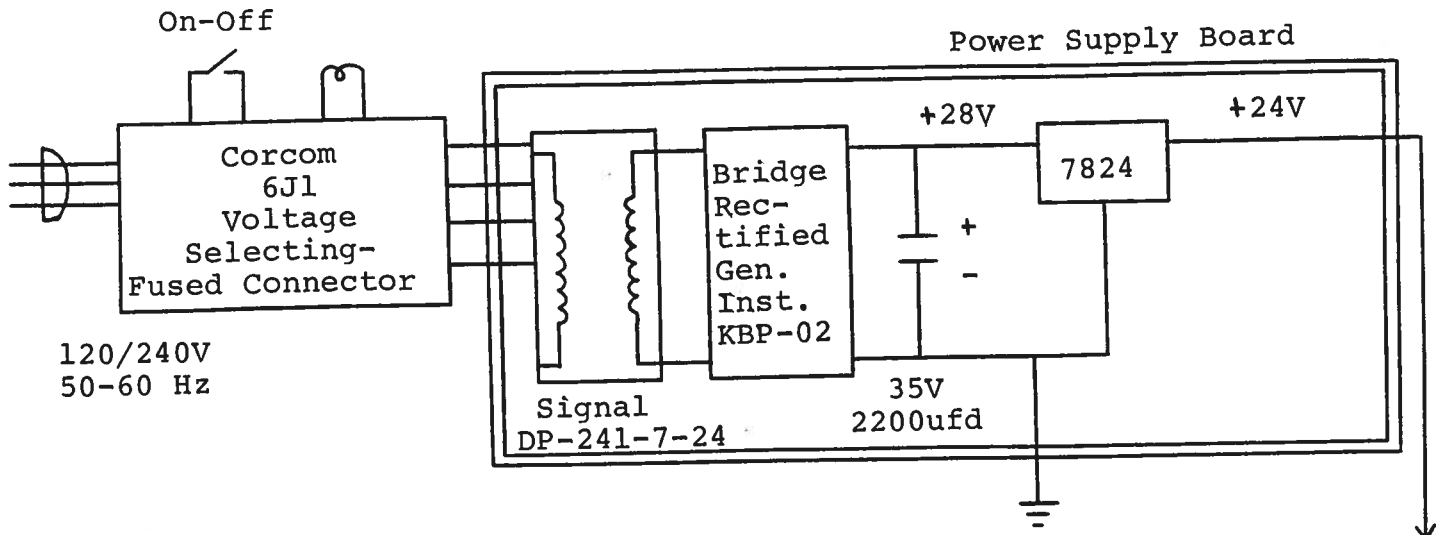

Schroff 09.17.92