

# AVTECH ELECTROSYSTEMS LTD.

NANOSECOND WAVEFORM ELECTRONICS  
ENGINEERING - MANUFACTURING

□ P.O. BOX 265  
OGDENSBURG  
NEW YORK  
13669  
(315) 472.5270

BOX 5120 STN. "F"  
OTTAWA, ONTARIO  
CANADA K2C 3H4  
(613) 226-5772  
TELEX 053.4591

## INSTRUCTIONS

MODEL AVRL-ITT3 PULSE GENERATOR

S.N. :

## WARRANTY

Avtech Electrosystems Ltd. warrants products of its manufacture to be free from defects in material and workmanship under conditions of normal use. If, within one year after delivery to the original owner, and after prepaid return by the original owner, this Avtech product is found to be defective, Avtech shall at its option repair or replace said defective item. This warranty does not apply to units which have been disassembled, modified or subjected to conditions exceeding the applicable specifications or ratings. This warranty is the extent of the obligation or liability assumed by Avtech with respect to this product and no other warranty or guarantee is either expressed or implied.

TEST ARRANGEMENT

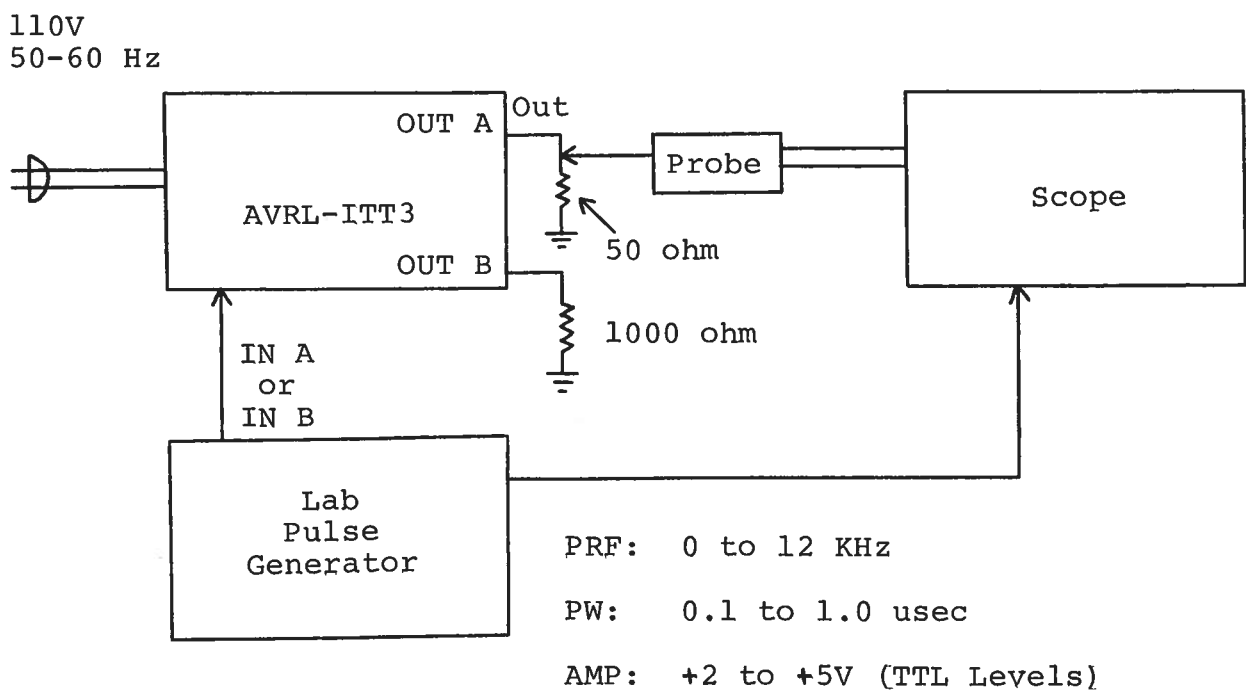

Notes:

- 1) The equipment should be connected in the general fashion shown above. A scope with a bandwidth of at least 50 MHz should be used to view output B while a scope bandwidth of at least 500 MHz is required for viewing output A.
- 2) Both output amplitudes are fixed at -250 volts. Care should be taken to insure that the scope, the load resistor and any attenuators used can withstand this high voltage.
- 3) The output pulse width for output A is variable from 5 nsec to 40 nsec. The output pulse width for output B is variable from 40 nsec to 3 usec using the front panel PW B and PW B FINE controls.
- 4) The output PRF is equal to the input PRF applied to the IN A or IN B ports. Outputs A and B will operate safely to PRF as high as 12 KHz. Note that both A and B outputs may fail if above PRF specifications are exceeded.
- 5) Output A is designed to operate into a fifty ohm load. The following arrangement is recommended when the AVRL-ITT1 unit is used to pulse a biased high impedance load (A out):

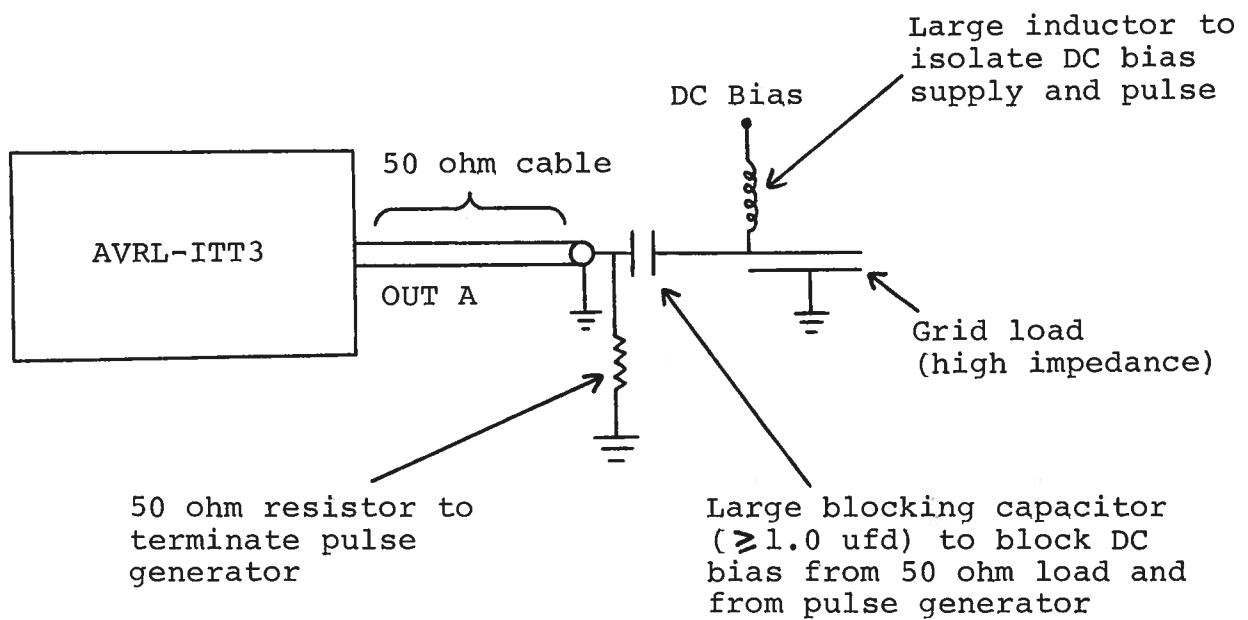

- 6) Output B is designed to operate directly into a high impedance load (1 K). WARNING: Output B may fail if operated into a 50 ohm load. The following arrangement is recommended when the B output is used to pulse a biased high impedance load:

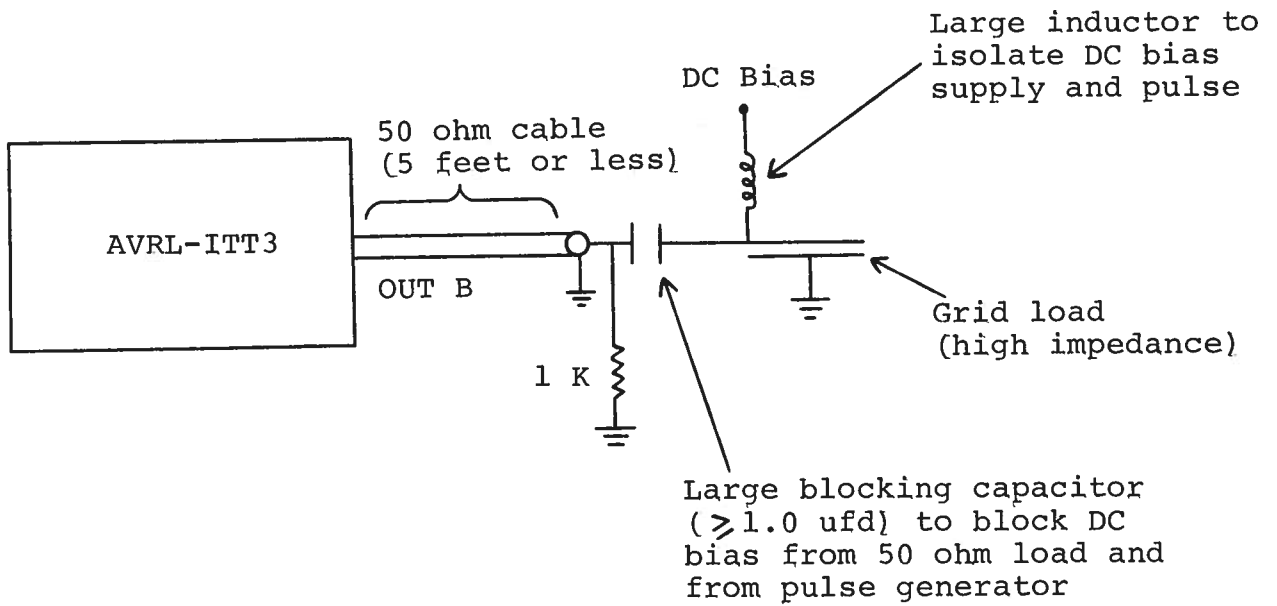

- 7) With the front panel delay switch in the IN position, the propagation delay time for the unit (for both output A and B) can be varied from about 300 nsec to about 3 usec using the delay A and delay B controls. With the switch in the OUT position, the propagation delay times are fixed at less than 300 nsec.
  
- 8) The output switching elements (SL4) in output B will probably fail if the output of the unit is accidentally short-circuited or if the unit is operated at high output pulse width - high PRF combinations. The switching elements are easily replaced following the instructions given in the REPAIR Section. The output switching elements in output A are also easily replaced.



FRONT PANEL CONTROLS

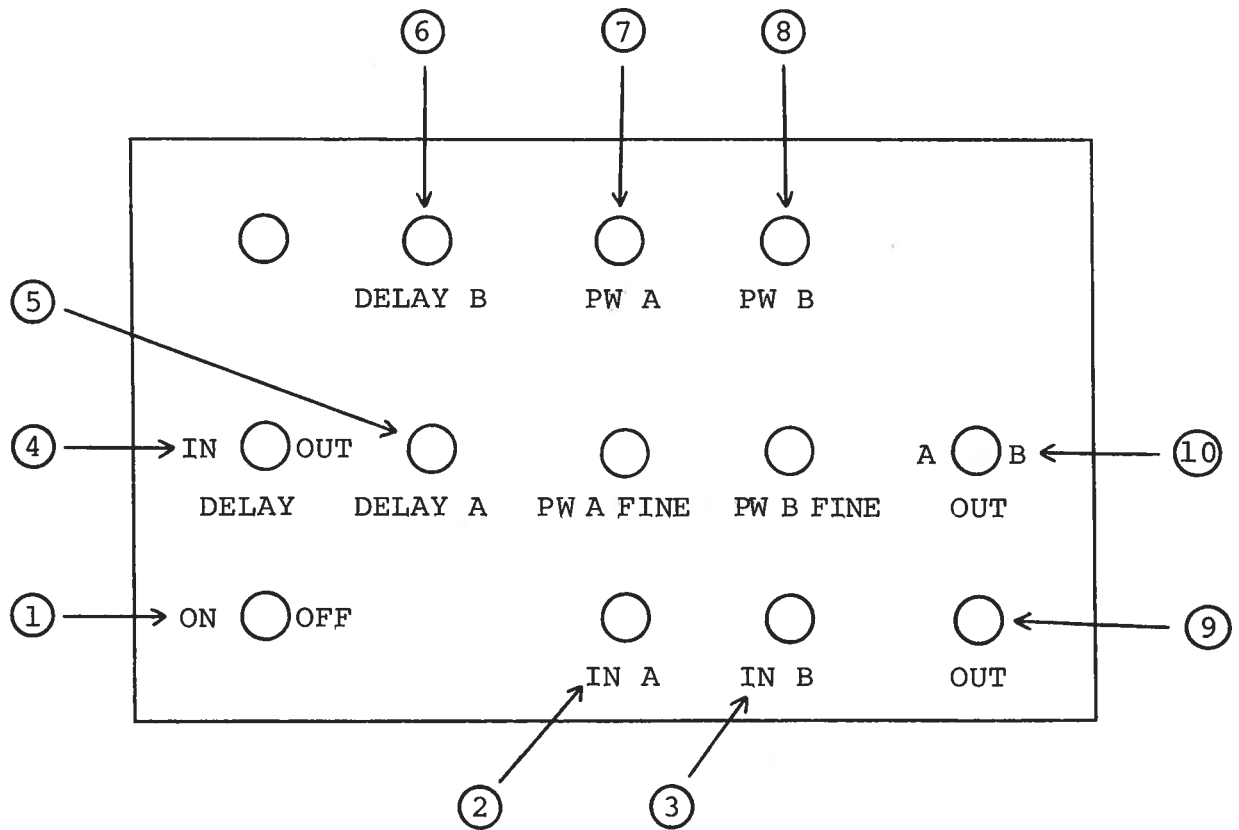

- (1) ON-OFF Switch. Applies prime power to all stages.
- (2) IN A. Input trigger for A output applied here (TTL levels 0.1 to 1.0 usec).
- (3) IN B. Input trigger for B output applied here (TTL levels 0.1 to 1.0 usec). IN A and IN B may be connected in parallel.
- (4) DELAY IN-OUT. With switch in the IN position the relative delay between the IN trigger pulse and output A (or B) is variable from 0.3 to 3 usec using the Delay A (or Delay B) control. With the switch in the OUT position the relative delay is fixed at about 300 nsec for the A output and 100 nsec for the B output.
- (5) DELAY A. One turn control to vary the delay of output A over the range of 0.3 to 3 usec.
- (6) DELAY B. One turn control to vary the delay of output B over the range of 0.3 to 3 usec.
- (7) PW A and PW A FINE. One turn controls used to vary output PW (A) from 5 to 40 nsec.
- (8) PW B and PW B FINE. One turn controls used to vary pulse width of output B from 40 nsec to 3 usec. PW B FINE is approximately one tenth as sensitive as PW B control.
- (9) OUT Connector. BNC connectors used to connect output of A to 50 ohm load and output of B to high impedance load.
- (10) A-B OUTPUT Switch. With switch in the A position, pulse generator A is connected to the output connector (10) and the B pulse generator is disabled. With switch in the B position, pulse generator B is connected to the output connector (10) and the A pulse generator is disabled.

BACK PANEL CONTROLS

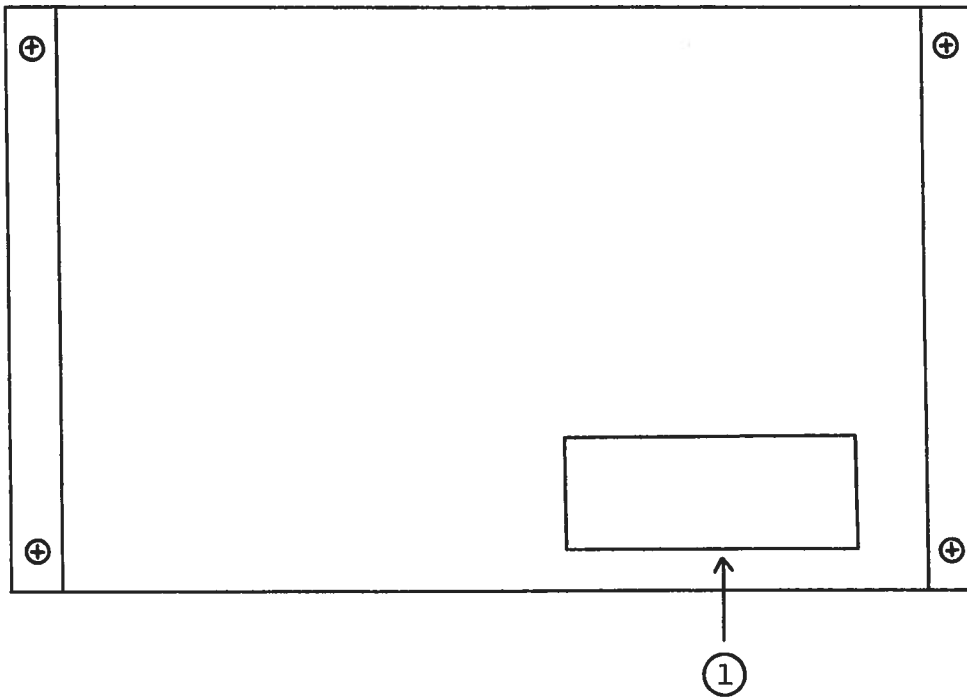

- (1) FUSED CONNECTOR, VOLTAGE SELECTOR. The detachable power cord is connected at this point. In addition, the removable cord is adjusted to select the desired input operating voltage. The unit also contains the main power fuse.

## REPAIR PROCEDURE

- 1) **WARNING:** Before attempting any repairs, note that potentials as high as 310 volts are employed in the chassis structure.
- 2) The pulse generator is constructed from the following subsystems or modules:
  - a) Metal chassis
  - b) A pulse generator module (AVL-2-PG-A)
  - c) Delay line module (AVRL-2-DL)
  - d) Timing module (AVL-2-T)
  - e) Power supply module (AVL-2-PS)
  - f) B pulse generator module (AVRL-PG-B)
  - g) Delay module (AVRL-ITT2-DL)
  - h) +24V power supply board

The modules are interconnected as shown in the following diagram.

- 3) If no output is provided by the A output, turn off the prime power and remove the four Phillips screws on the back panel. The top cover may then be slid off. Turn on the prime power and apply a scope probe or voltmeter to the outer case of either of the SL3 switching elements. A voltage of about +310 volts should be indicated. If the voltage is substantially less than 310V then one of the switching elements has probably failed. Turn off the prime power and remove one of the transistors by removing the two 2-56 screws which secure the transistor in its socket. Pull the transistor out of the socket. With the unit un-triggered, turn on the prime power supply and measure the voltage from the case of the remaining transistor to ground. If this voltage is about 310 volts then the transistor which was removed is defective and should be replaced. If the voltage which is measured is less than 310 volts then the transistor still in position is defective and should be replaced. Note that the two transistors are completely interchangeable (Order Avtech Part No. SL3).
- 4) If no output is provided by the B output, then it is most likely that the SL4 switching elements in the B output stage have been damaged and should be replaced. Turn off the prime power and remove the instrument bottom panel cover plate thereby exposing the SL4 switching elements. The SL4 elements may be removed from their sockets using a pair of needle nosed pliers. Before attempting this, first insure that the prime power is off and also briefly ground the metal tabs on the SL4 elements to the chassis as the bypass capacitors

may be charged to -260 volts. Replacement SL4 units must be ordered directly from Avtech. When reinstalling the SL4 units in their sockets, insure that the shortest of the three terminals is adjacent to the black dot on the AVRL chassis.

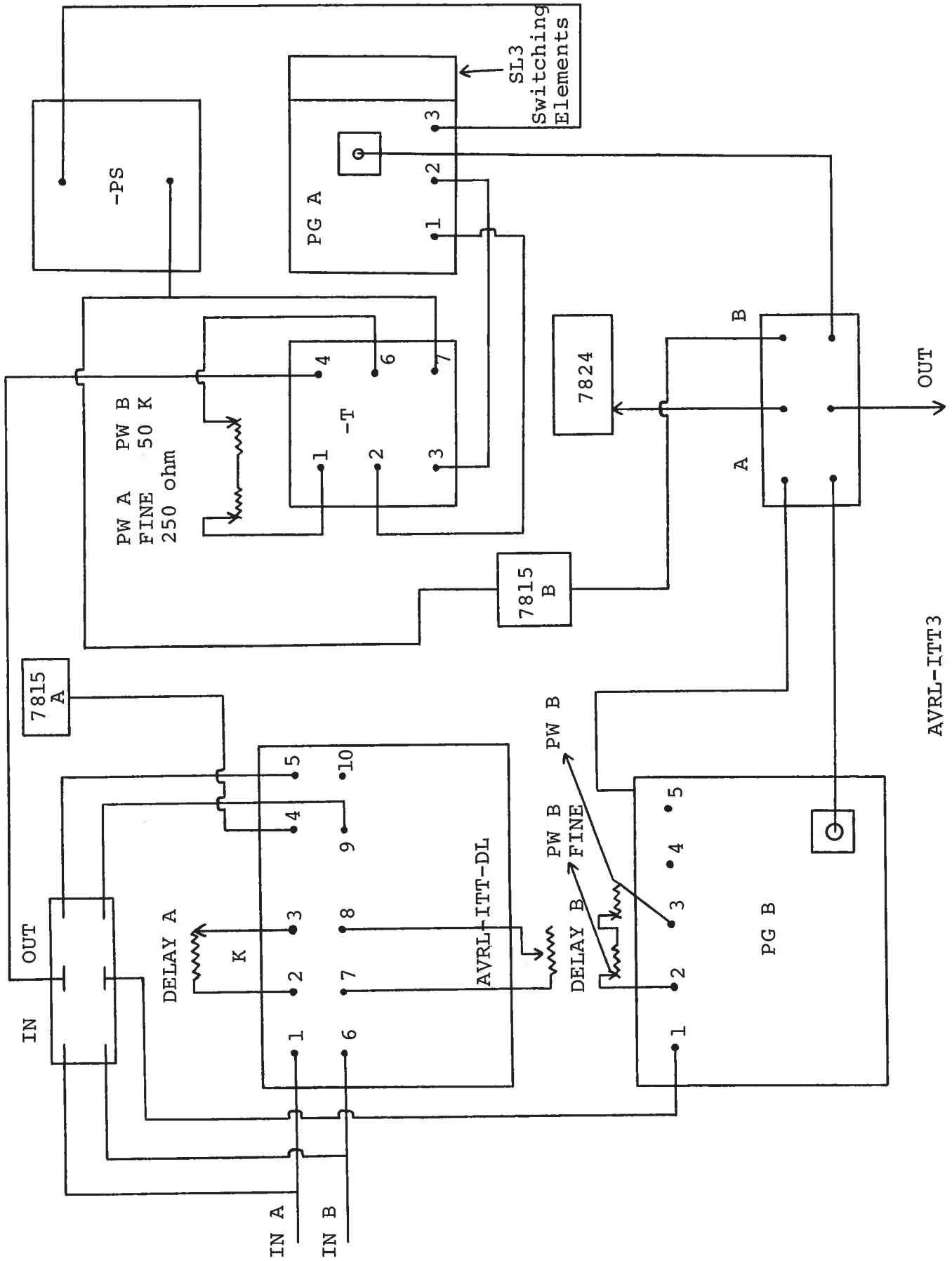

AVRL-I TT3

### +24 VOLT POWER SUPPLY

The AVRL-ITT3 consists of the six standard modules and a power supply board which supplies +24 volts (600 mA max) to the modules. In the event that the unit malfunctions, remove the instrument top cover, thereby exposing the modules. Measure the voltage at the +24 V pin of the PS module. If this voltage is substantially less than +24 volts, unsolder the line connecting the power supply board output and connect a 50 ohm 10 W load to the power supply output. The voltage across this load should be about +24 V DC. If this voltage is substantially less than 24 volts the power supply board is defective and should be repaired or replaced. If the voltage is near +24V then see instructions in preceding section.



POWER SUPPLY BOARD

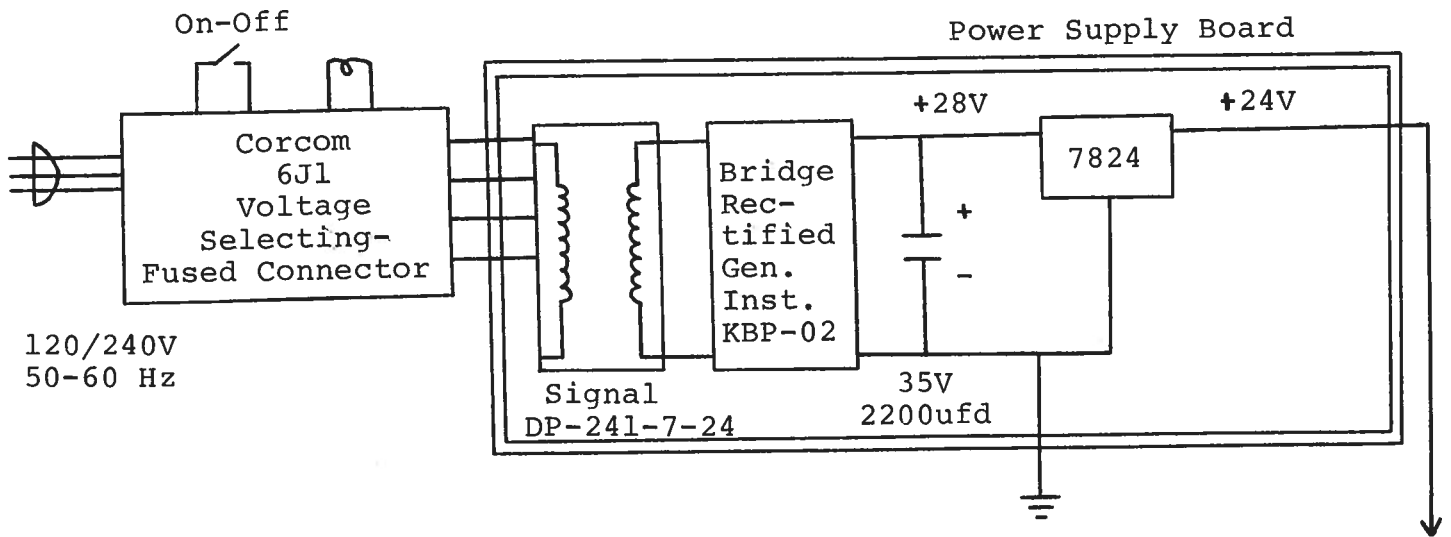

120/240V  
50-60 Hz

Schroff

