

# AVTECH ELECTROSYSTEMS LTD.

NANOSECOND WAVEFORM ELECTRONICS  
ENGINEERING . MANUFACTURING

□ P.O. BOX 265  
OGDENSBURG  
NEW YORK  
13669  
(315) 472-5270

✕ BOX 5120 STN. "F"  
OTTAWA, ONTARIO  
CANADA K2C 3H4  
(613) 226-5772  
TELEX 053-4591

## INSTRUCTIONS

MODEL AVRL-ITT5B PULSE GENERATOR

S.N. :

### WARRANTY

Avtech Electrosystems Ltd. warrants products of its manufacture to be free from defects in material and workmanship under conditions of normal use. If, within one year after delivery to the original owner, and after prepaid return by the original owner, this Avtech product is found to be defective, Avtech shall at its option repair or replace said defective item. This warranty does not apply to units which have been disassembled, modified or subjected to conditions exceeding the applicable specifications or ratings. This warranty is the extent of the obligation or liability assumed by Avtech with respect to this product and no other warranty or guarantee is either expressed or implied.

TEST ARRANGEMENT

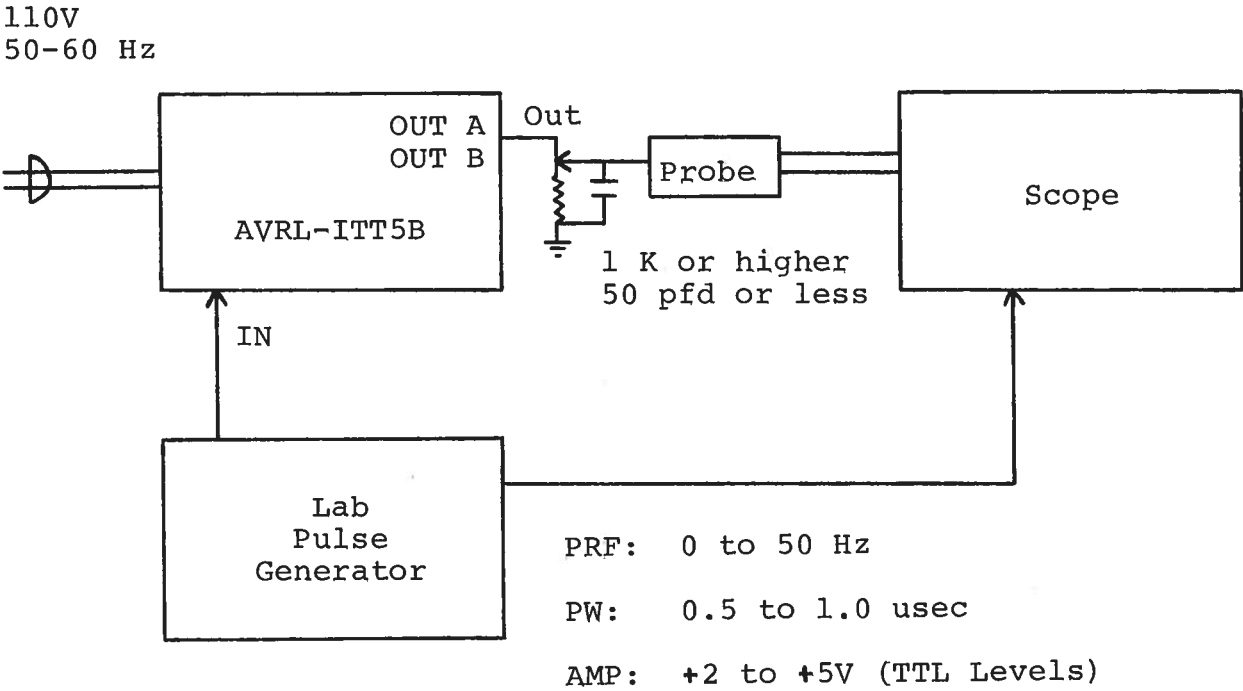

Notes:

- 1) The equipment should be connected in the general fashion shown above. A scope with a bandwidth of at least 50 MHz should be used to view the outputs.
- 2) Both output amplitudes are fixed at -250 V. Care should be taken to insure that the scope and the load resistor can withstand this high voltage (and high output power for wide output pulse widths).
- 3) The output pulse width for output A is variable from 20 nsec to 100 nsec. The output pulse width for output B is variable from 100 nsec to 5 msec.
- 4) The output PRF is equal to the input PRF applied to the IN port. Note that both A and B outputs may fail if above PRF specifications and duty cycle are exceeded or if the load capacitance specification is exceeded.
- 5) Outputs A and B are designed to operate directly into a high impedance load (1 K or higher). **WARNING:** Unit may fail if operated into a 50 ohm load. The following arrangement is recommended when the unit is used to pulse a biased high impedance load:

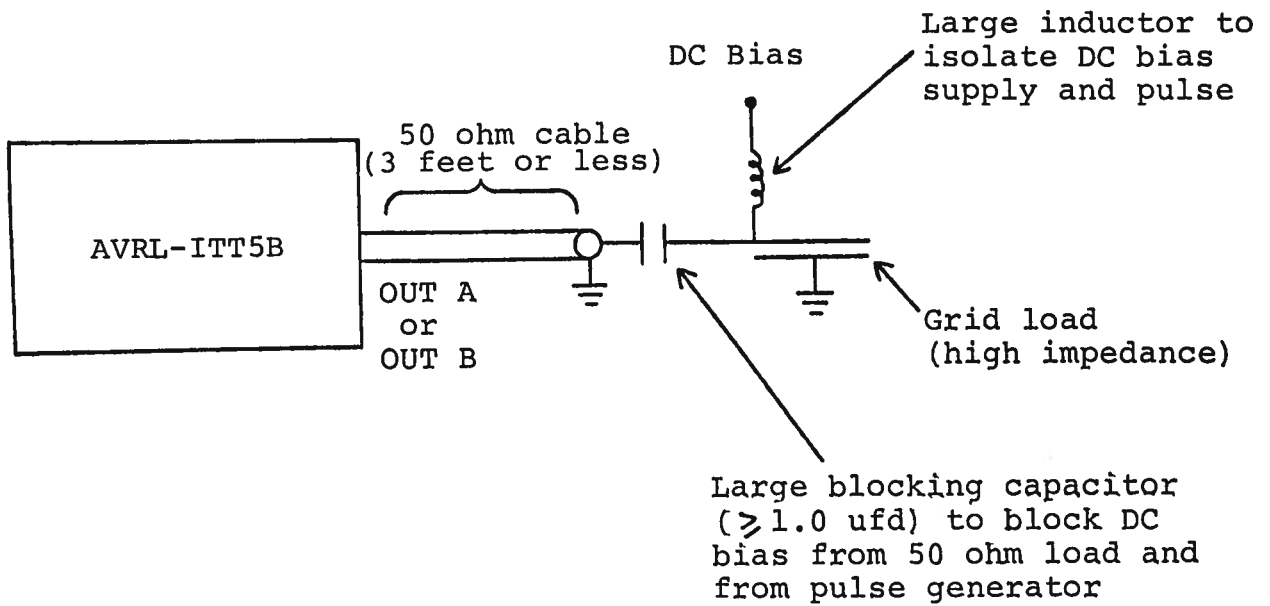

- 6) The output switching elements (SL9H) will probably fail if the output of the unit is accidentally short-circuited or if the unit is operated at high output pulse width - high PRF combinations. The switching elements are easily replaced following the instructions given in the REPAIR Section.
  
- 7) CAUTION: The instrument will be damaged if the load capacitance exceeds 50 pfd or if the load resistance is less than 1 K. Note that coaxial cables connected to the pulse generator output ports typically contribute 15 pfd per foot of length and so this capacitance must be included in the total.

FRONT PANEL CONTROLS

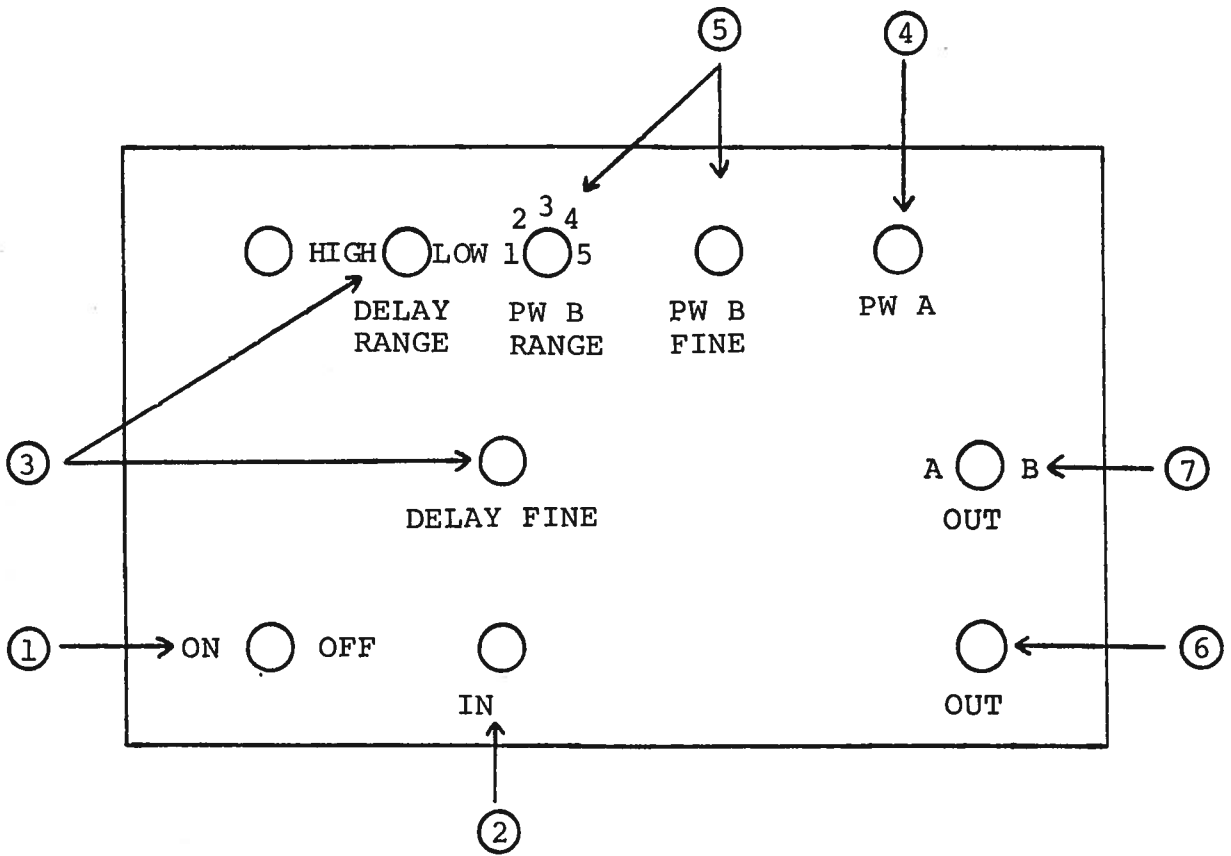

- (1) ON-OFF Switch. Applies prime power to all stages.
- (2) IN. Input trigger for A and B outputs applied here (TTL levels, 0.5 to 1.0 usec).
- (3) DELAY RANGE, DELAY FINE. Varies propagation delay from IN to OUT as follows:

|       | A OUT               | B OUT                |
|-------|---------------------|----------------------|
| LOW:  | 30 nsec to 100 nsec | 100 nsec to 200 nsec |
| HIGH: | 100 nsec to 2 usec  | 200 nsec to 2 usec   |

- (4) PW A. One turn control used to vary output PW (A) from 20 to 100 nsec.
- (5) PW B. One turn control and 5 position range switch used to vary pulse width of output B from 100 nsec to 5 msec as follows:

|          |                      |
|----------|----------------------|
| RANGE 1: | 100 nsec to 1.7 usec |
| RANGE 2: | 1 usec to 13 usec    |
| RANGE 3: | 6.5 usec to 125 usec |
| RANGE 4: | 86 usec to 1.2 msec  |
| RANGE 5: | 0.6 msec to 6 msec   |

- (6) OUT Connector. BNC connectors used to connect output of A and output of B to high impedance load.
- (7) A-B OUTPUT Switch. With switch in the A position, pulse generator A is connected to the output connector (8) and the B pulse generator is disabled. With switch in the B position, pulse generator B is connected to the output connector (8) and the A pulse generator is disabled.



BACK PANEL CONTROLS

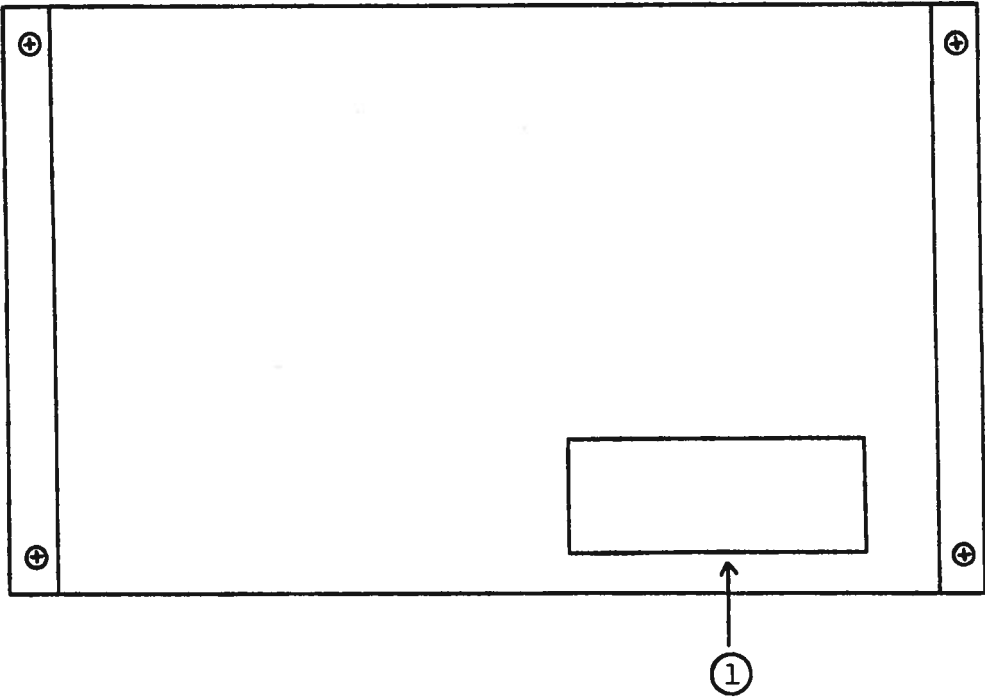

(1) FUSED CONNECTOR, VOLTAGE SELECTOR. The detachable power cord is connected at this point. In addition, the removable cord is adjusted to select the desired input operating voltage. The unit also contains the main power fuse.

## REPAIR PROCEDURE

- 1) **WARNING:** Before attempting any repairs, note that potentials as high as 260 volts are employed in the chassis structure.
- 2) The pulse generator is constructed from the following subsystems or modules:
  - a) Metal chassis
  - b) A pulse generator module (AVRL-ITT5B-PGA)
  - c) B pulse generator module (AVRL-ITT5B-PGB)
  - d) Delay module (AVRL-ITT5B-D-PW)
  - e) +24V power supply board
  - f) B pulse generator power supply (AVRL-ITT5B-PSB)

The modules are interconnected as shown in the following diagram.

- 3) If no output is provided by the A or B outputs then it is most likely that the SL9H switching elements in the output stages have been damaged and should be replaced using the following procedure:
  - i) Turn off prime power and remove cover plate on bottom of instrument (four 2-56 screws).
  - ii) By means of a screwdriver, briefly ground the tabs of the two SL9H transistors to discharge the bypass capacitors.
  - iii) Extract the old SL9H transistors from their socket by means of needle-nosed pliers.
  - iv) Install replacement SL9H transistors and install cover plate.

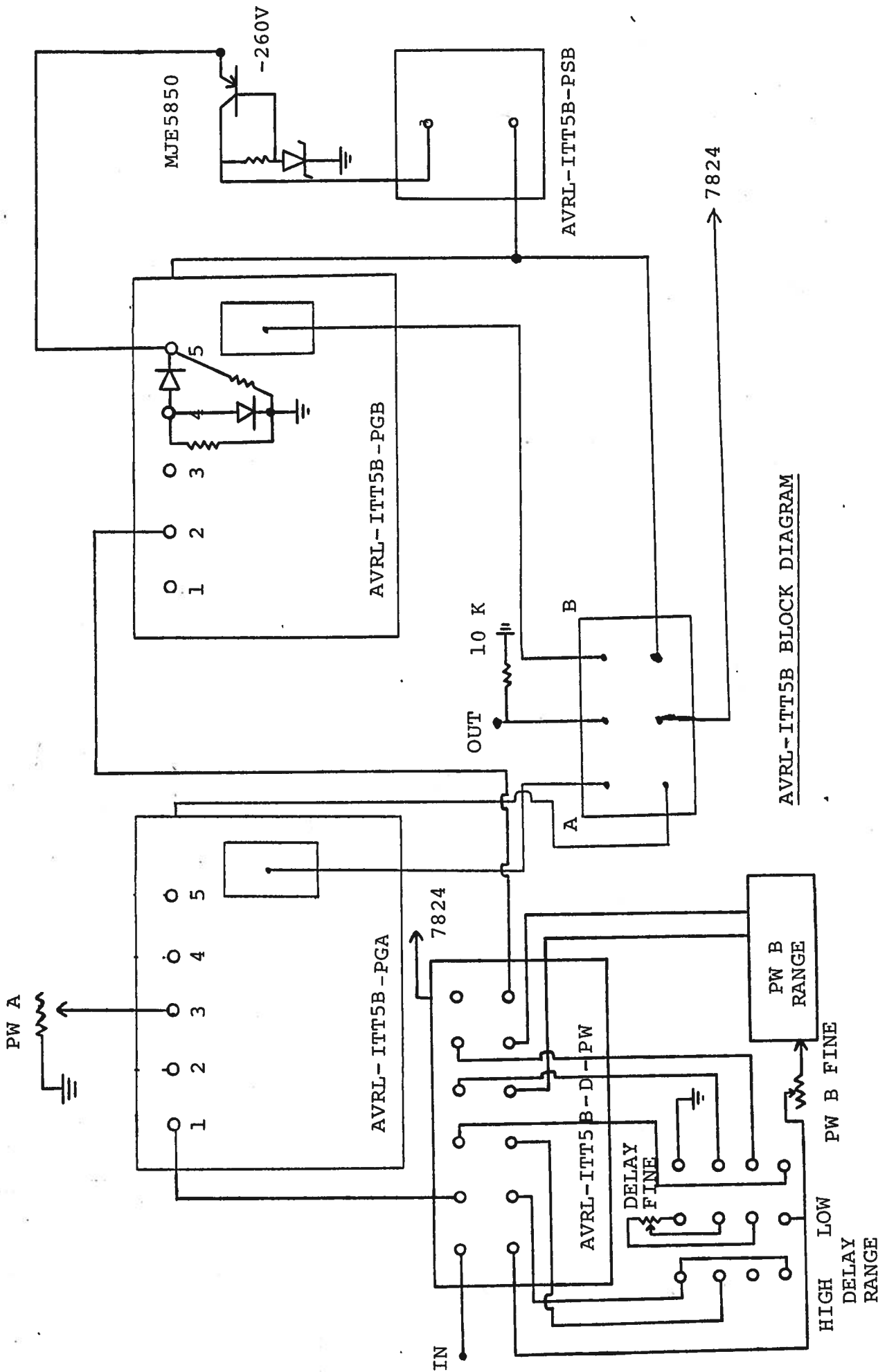

AVRL-ITT5B BLOCK DIAGRAM

### +24 VOLT POWER SUPPLY

The AVRL-ITT5B consists of the four standard modules and a power supply board which supplies +24 volts (600 mA max) to the modules. In the event that the unit malfunctions, remove the instrument top cover, thereby exposing the modules. Measure the voltage at the +24 V pin of the PS module. If this voltage is substantially less than +24 volts, unsolder the line connecting the power supply board output and connect a 50 ohm 10 W load to the power supply output. The voltage across this load should be about +24 V DC. If this voltage is substantially less than 24 volts the power supply board is defective and should be repaired or replaced. If the voltage is near +24V then see instructions in preceding section.

POWER SUPPLY BOARD

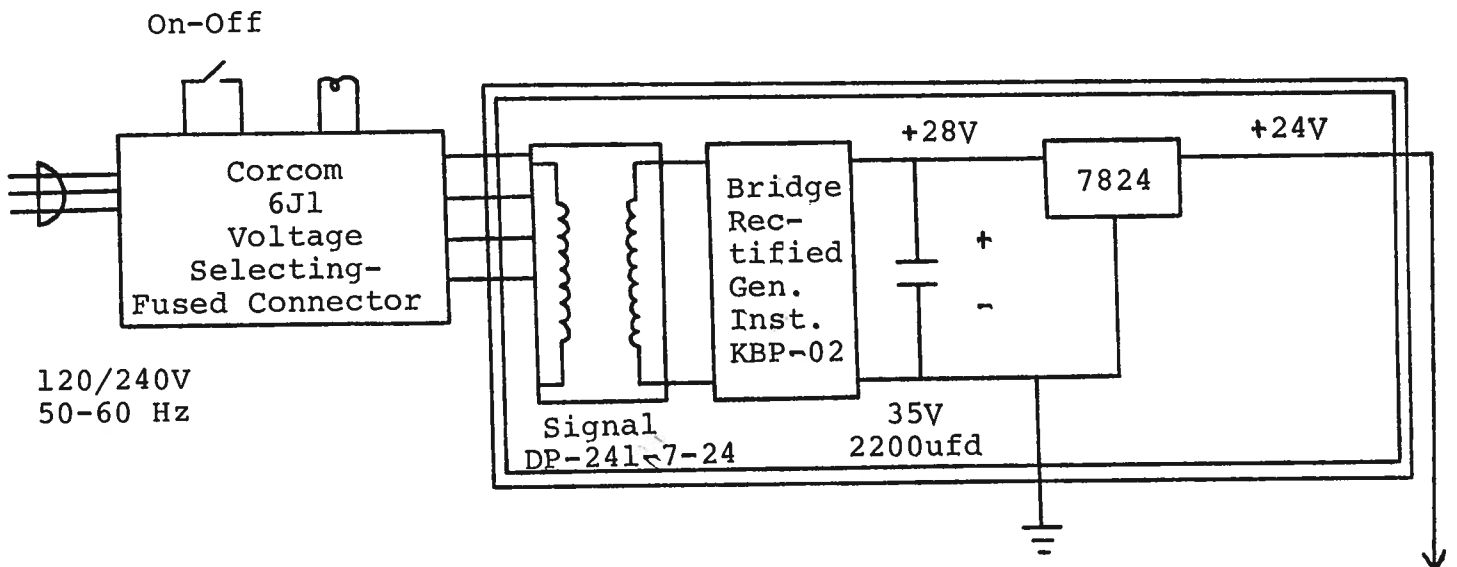

120/240V  
50-60 Hz

Schroff

11.27.85