

# AVTECH ELECTROSYSTEMS LTD.

NANOSECOND WAVEFORM ELECTRONICS  
ENGINEERING - MANUFACTURING

□ P.O. BOX 265  
OGDENSBURG  
NEW YORK  
13669  
(315) 472-5270

☒ BOX 5120, STN. "F"  
OTTAWA, ONTARIO  
CANADA K2C 3H4  
TEL: (613) 226-5772  
FAX: (613) 226-2802  
TELEX: 053-4591

## INSTRUCTIONS

MODEL AVRL-ITT7E-0S-MOD1 PULSE GENERATOR

S.N. :

## WARRANTY

Avtech Electrosystems Ltd. warrants products of its manufacture to be free from defects in material and workmanship under conditions of normal use. If, within one year after delivery to the original owner, and after prepaid return by the original owner, this Avtech product is found to be defective, Avtech shall at its option repair or replace said defective item. This warranty does not apply to units which have been disassembled, modified or subjected to conditions exceeding the applicable specifications or ratings. This warranty is the extent of the obligation or liability assumed by Avtech with respect to this product and no other warranty or guarantee is either expressed or implied.

TEST ARRANGEMENT

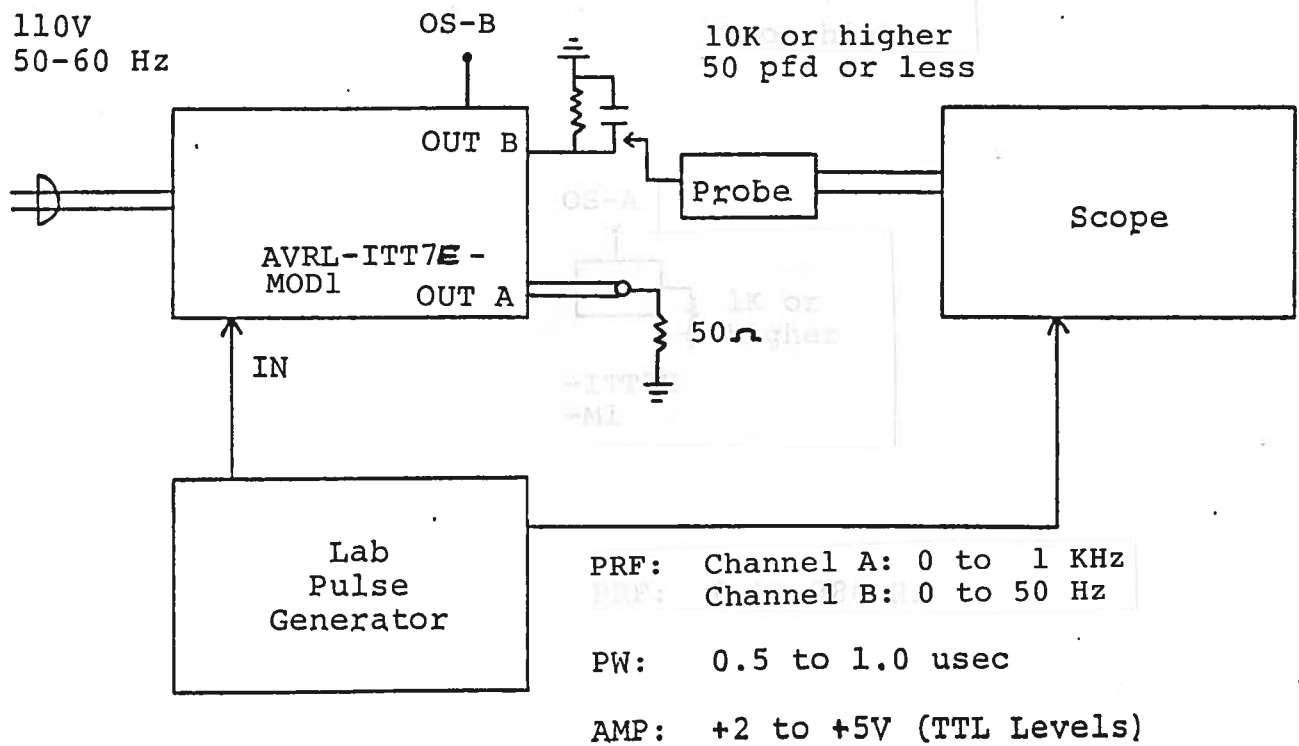

Notes:

- 1) The equipment should be connected in the general fashion shown above. A scope with a bandwidth of at least 50 MHz should be used to view the outputs.
- 2) Output A amplitude is fixed at about -320 volts while output B amplitude is fixed at about -215 volts. Care should be taken to insure that the scope and the load resistor can withstand this high voltage (and high output power for wide output pulse widths).
- 3) The recommended arrangements for connecting to the ITT load are as follows:

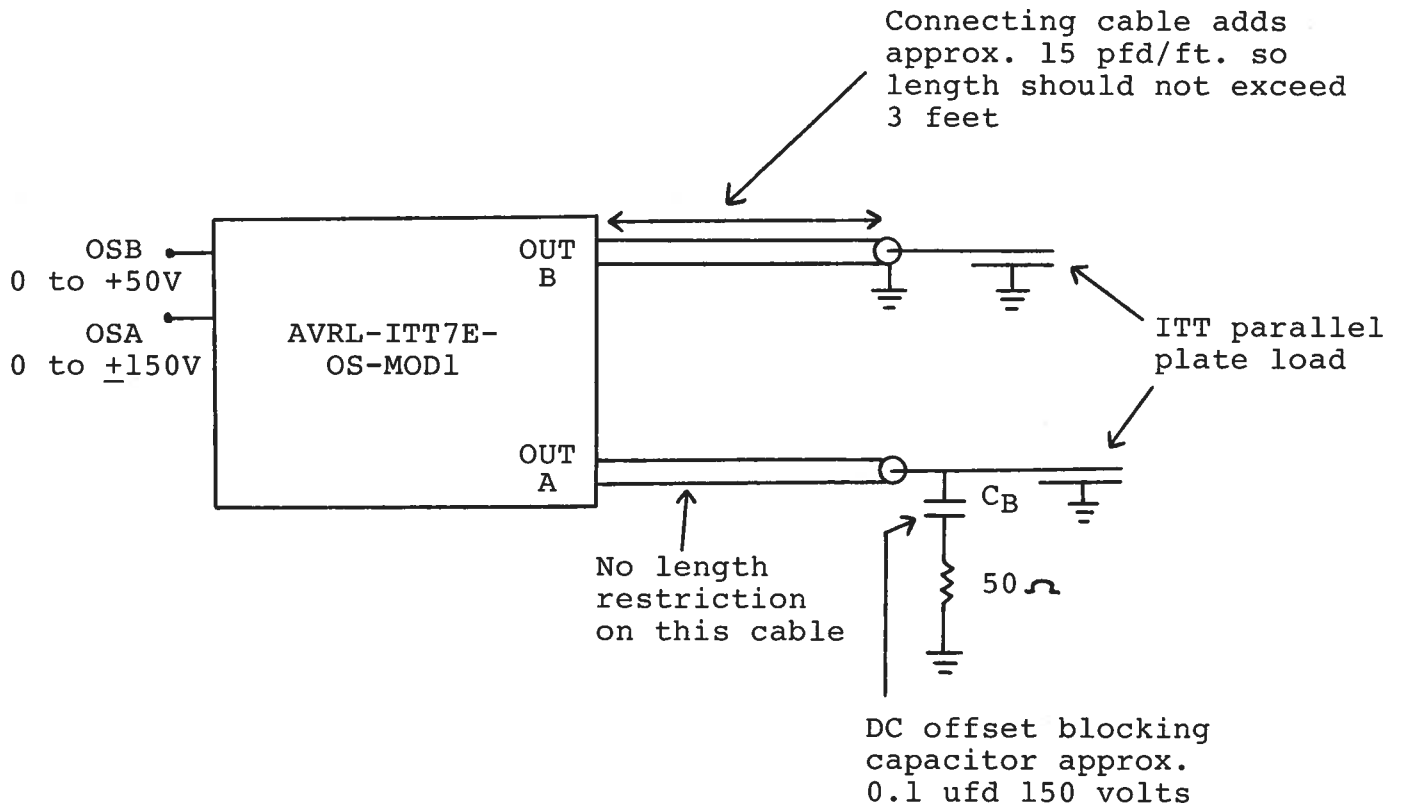

- 4) The output pulse width for output A is variable from 6 nsec to 80 nsec by means of the ten turn PW A control.
- 5) The output PW for output B is variable from 80 nsec to 5 msec via the 5 position range switch and ten turn control (PW B).
- 6) The output PRF is equal to the input PRF applied to the IN port. The propagation delay for channels A and B is less than 80 nsec.
- 7) To offset output A connect the desired offset voltage (0 to  $\pm 150$  volts) to the OS A terminals on the back panel.
- 8) To offset output B connect the desired offset voltage (0 to +50 volts) to the back panel OS B terminals.
- 9) The output switching elements (SL9H) for output B will probably fail if the output of the unit is accidentally short-circuited or operated into 50 ohms or if the unit is operated at high output pulse width - high PRF combinations. The switching elements are easily replaced following the instructions given in the REPAIR Section.
- 10) The monitor output A provides a 1 volt (to 50 ohm) replica of the output A. The monitor output B provides a 1 volt (to 50 ohm) replica of the output B.
- 11) Channel A will safely operate over the PRF range of 0 to 4 KHz. Channel B is designed to operate at a PRF of 50 Hz but will operate safely at higher PRF if the PW is reduced as follows:

<u>PRF</u>	<u>PW_MAX</u>
50 Hz	5.0 msec
500 Hz	500 usec
5000 Hz	50 usec

FRONT PANEL CONTROLS

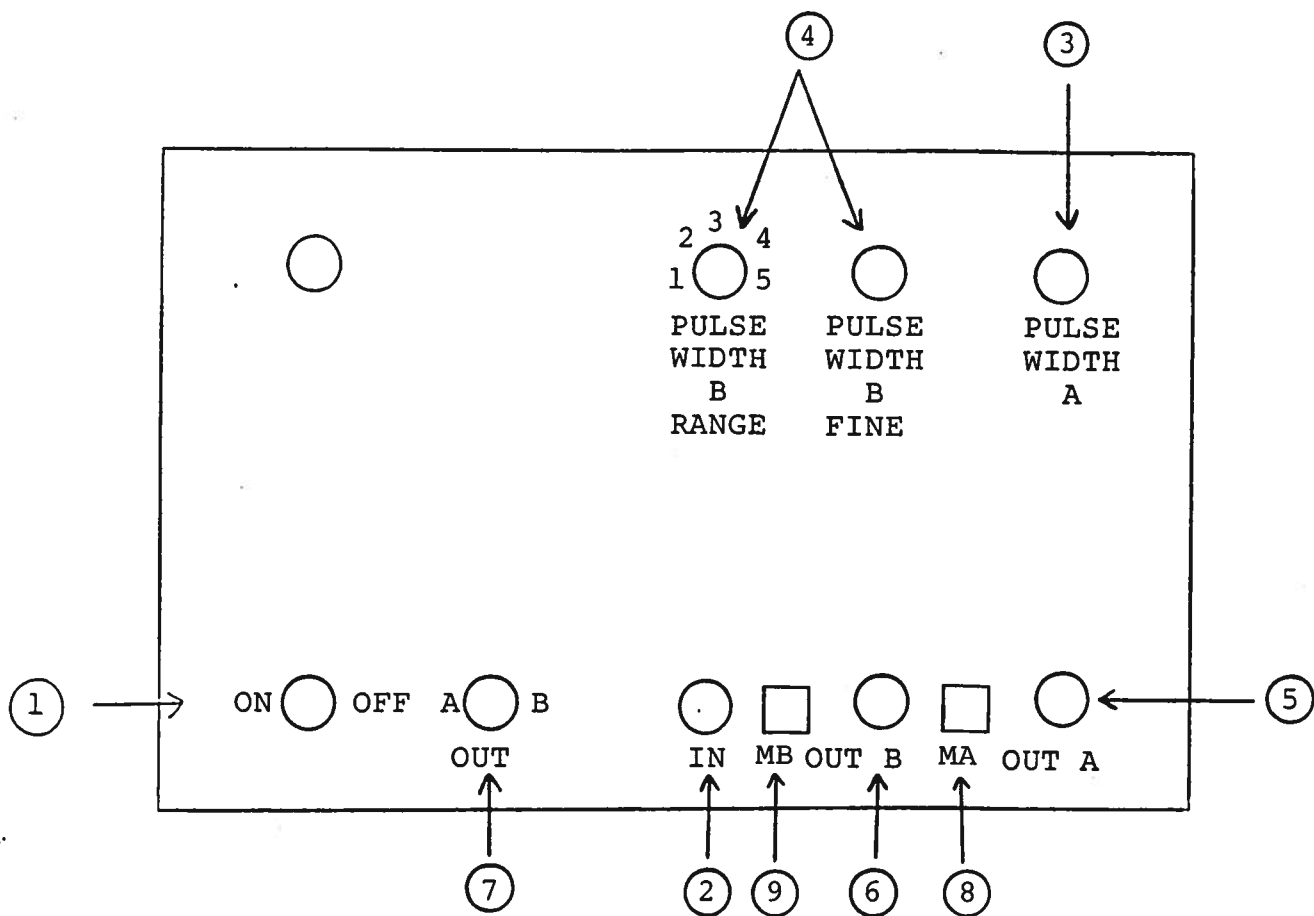

- (1) ON-OFF Switch. Applies prime power to all stages.
- (2) IN. Input trigger for A and B outputs applied here (TTL levels, 0.5 to 1.0 usec).
- (3) PW A. Ten turn control will vary PW of A output from 6 to 80 nsec.
- (4) PW B. Ten turn control and 5 position range switch used to vary pulse width of output B from 80 nsec to 5.0 msec as follows:
  - RANGE 1: 80 nsec to 0.8 usec
  - RANGE 2: 0.6 usec to 72 usec
  - RANGE 3: 6.5 usec to 67 usec
  - RANGE 4: 50 usec to 660 usec
  - RANGE 5: 600 usec to 5.2 msec
- (5) OUT A Connector. SMA connector used to connect output A to 50 ohm load.
- (6) OUT B Connector. BNC connector used to connect output of B to high impedance load.
- (7) A-B OUTPUT Switch. With switch in the A position, pulse generator A is connected to the output connector (A) and the B pulse generator is disabled. With switch in the B position, pulse generator B is connected to the output connector (B) and the A pulse generator is disabled.
- (8) MA. Provides 1 volt (to 50 ohm) replica of channel A output.
- (9) MB. Provides 1 volt (to 50 ohm) replica of channel B output.

BACK PANEL CONTROLS

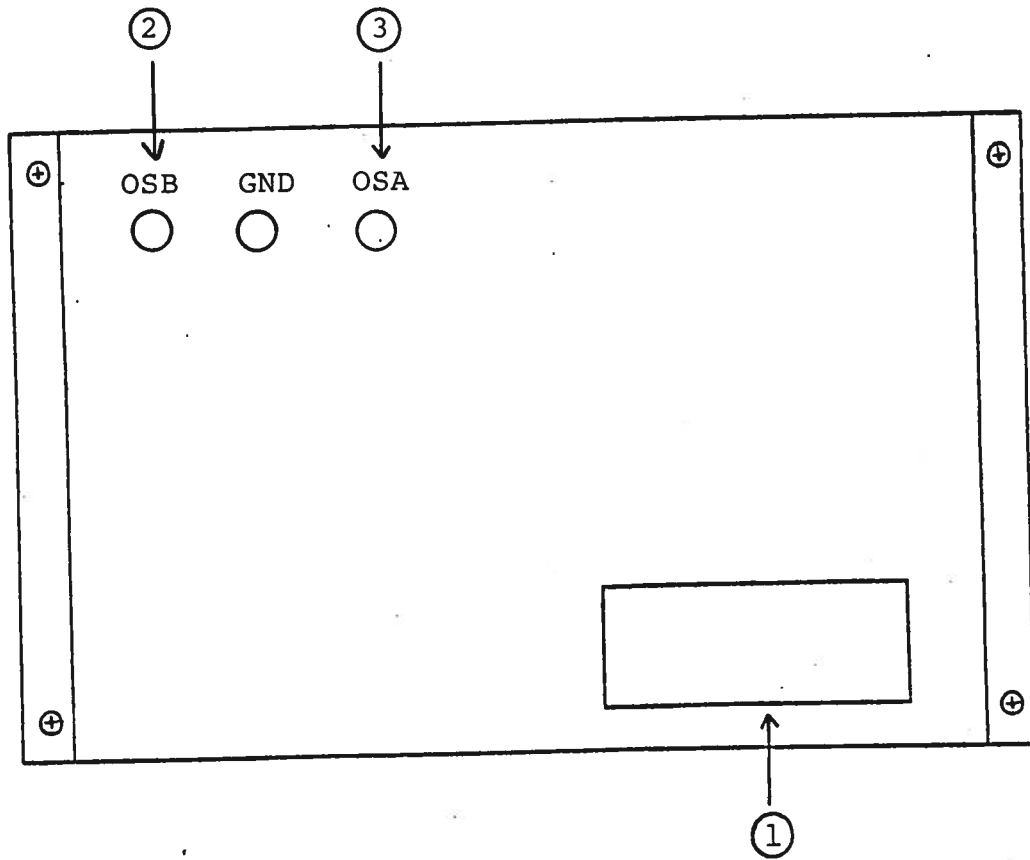



- (1) FUSED CONNECTOR, VOLTAGE SELECTOR. The detachable power cord is connected at this point. In addition, the removable cord is adjusted to select the desired input operating voltage. The unit also contains the main power fuse.
- (2) OS-B. To offset output B, apply desired DC offset (0 to +50 volts) to OS-B solder terminals.
- (3) OS-A. To offset output A, apply desired DC offset (0 to +150 volts) to OSA solder terminals. Note that a DC blocking capacitor (approx. 0.1 ufd 150 volts) must be placed in series with 50 ohm load termination.

## REPAIR PROCEDURE

- 1) **WARNING:** Before attempting any repairs, note that potentials as high as 360 volts are employed in the chassis structure.
- 2) The pulse generator is constructed from the following subsystems or modules:
  - a) Metal chassis
  - b) A pulse generator module (AVRL-ITT7E-PGA-M1)
  - c) B pulse generator module (AVRL-ITT7E-PGB-M1)
  - d) Delay module (ITT7E-T-M1)
  - e) +24V power supply board
  - f) B pulse generator power supply (AVRL-ITT7E-PSB)
  - g) A pulse generator power supply (AVRL-ITT7E-PSA)
  - h) Output B PW control module (ITT7E-PWB-M1)
  - i) -10 volts supply module (ITT7E-PS-10)
  - j) Delay module (ITT7E-DL-M1)

The modules are interconnected as shown in the following diagram.

- 3) If no output is provided by the B output then it is most likely that the SL9H switching elements in the output stages have been damaged and should be replaced using the following procedure:
  - i) Turn off prime power and remove cover plate on bottom of instrument (two 2-56 screws).
  - ii) By means of a screwdriver, briefly ground the tabs of the two SL9H transistors to discharge the bypass capacitors.
  - iii) Extract the old SL9H transistors from their socket by means of needle-nosed pliers.
  - iv) Install replacement SL9H transistors and install cover plate.
- 4) If no output is provided by the A output then it is most likely that the SL3 switching elements in the output stages have been damaged and should be replaced using the following procedure:
  - i) Turn off prime power and remove the four Phillips screws on the back panel of the instrument. The front cover may then be slid off.
  - ii) By means of a screwdriver, briefly ground the cases of the two SL3 transistors to discharge the bypass capacitors.

- iii) Extract the old SL3 transistors from their sockets after removing the 4 2-56 screws.
- iv) Install replacement SL3 transistors and install cover plate.

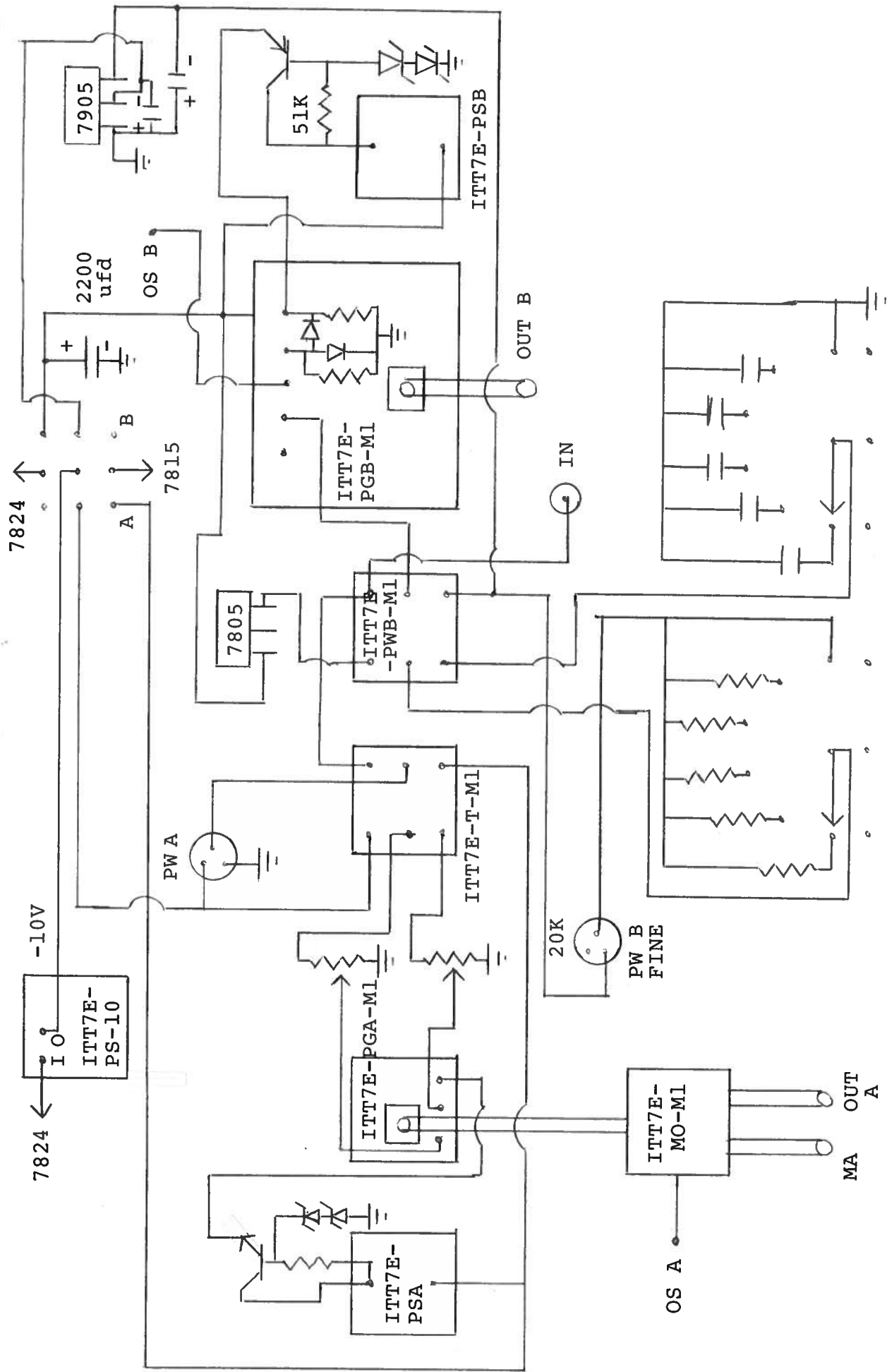

AVRL-ITT7E-OS-MOD1

POWER SUPPLY BOARD

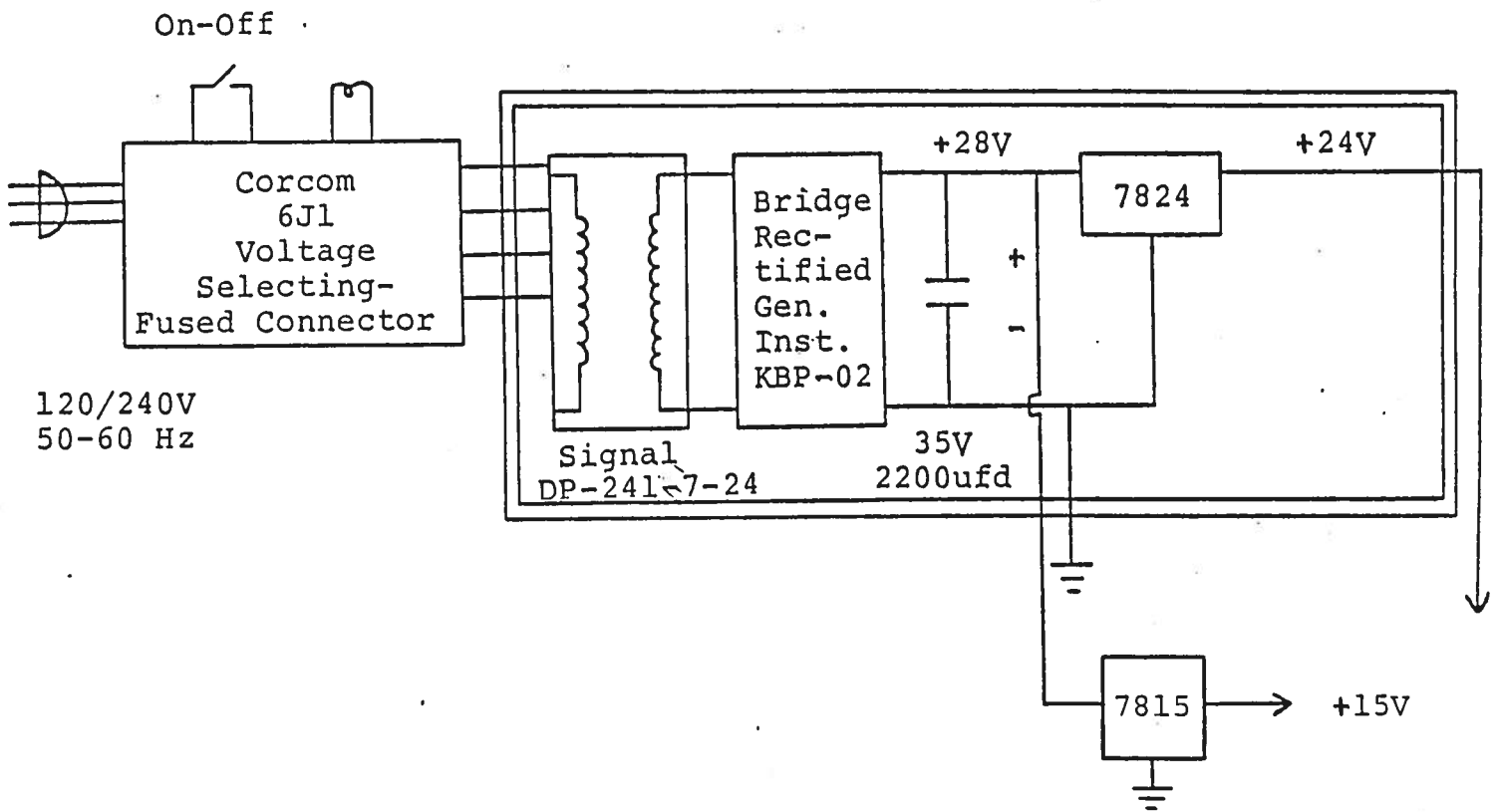

## +24 VOLT POWER SUPPLY

The AVRL-ITT7E consists of the six standard modules and a power supply board which supplies +24 volts (600 mA max) to the modules. In the event that the unit malfunctions, remove the instrument top cover, thereby exposing the modules. Measure the voltage at the +24 V pin of the PS module. If this voltage is substantially less than +24 volts, unsolder the line connecting the power supply board output and connect a 50 ohm 10 W load to the power supply output. The voltage across this load should be about +24 V DC. If this voltage is substantially less than 24 volts the power supply board is defective and should be repaired or replaced. If the voltage is near +24V then see instructions in preceding section.

Schroff

02.17.89

1748 1000 1000 1000

1

the first of these is the fact that the  
of the second is the fact that the  
of the third is the fact that the  
of the fourth is the fact that the  
of the fifth is the fact that the  
of the sixth is the fact that the  
of the seventh is the fact that the  
of the eighth is the fact that the  
of the ninth is the fact that the  
of the tenth is the fact that the