



**AVTECH ELECTROSYSTEMS LTD.**

NANOSECOND WAVEFORM ELECTRONICS  
SINCE 1975

P.O. BOX 265  
OGDENSBURG, NY  
U.S.A. 13669-0265  
TEL: (315) 472-5270  
FAX: (613) 226-2802

TEL: 1-800-265-6681  
FAX: 1-800-561-1970

e-mail: [info@avtechpulse.com](mailto:info@avtechpulse.com)  
<http://www.avtechpulse.com>

P.O. BOX 5120 STN. F  
OTTAWA, ONTARIO  
CANADA K2C 3H4  
TEL: (613) 226-5772  
FAX: (613) 226-2802

**INSTRUCTIONS**

**MODEL AVS-100-PS SAMPLE AND HOLD UNIT**

**S.N.:**

#### WARRANTY

Avtech Electrosystems Ltd. warrants products of its manufacture to be free from defects in material and workmanship under conditions of normal use. If, within one year after delivery to the original owner, and after prepaid return by the original owner, this Avtech product is found to be defective, Avtech shall at its option repair or replace said defective item. This warranty does not apply to units which have been disassembled, modified or subjected to conditions exceeding the applicable specifications or ratings. This warranty is the extent of the obligation assumed by Avtech with respect to this product and no other warranty or guarantee is either expressed or implied.

#### TECHNICAL SUPPORT

Phone: 613-226-5772 or 1-800-265-6681

Fax: 613-226-2802 or 1-800-561-1970

E-mail: [info@avtechpulse.com](mailto:info@avtechpulse.com)

World Wide Web: <http://www.avtechpulse.com>

FRONT PANEL CONTROLS

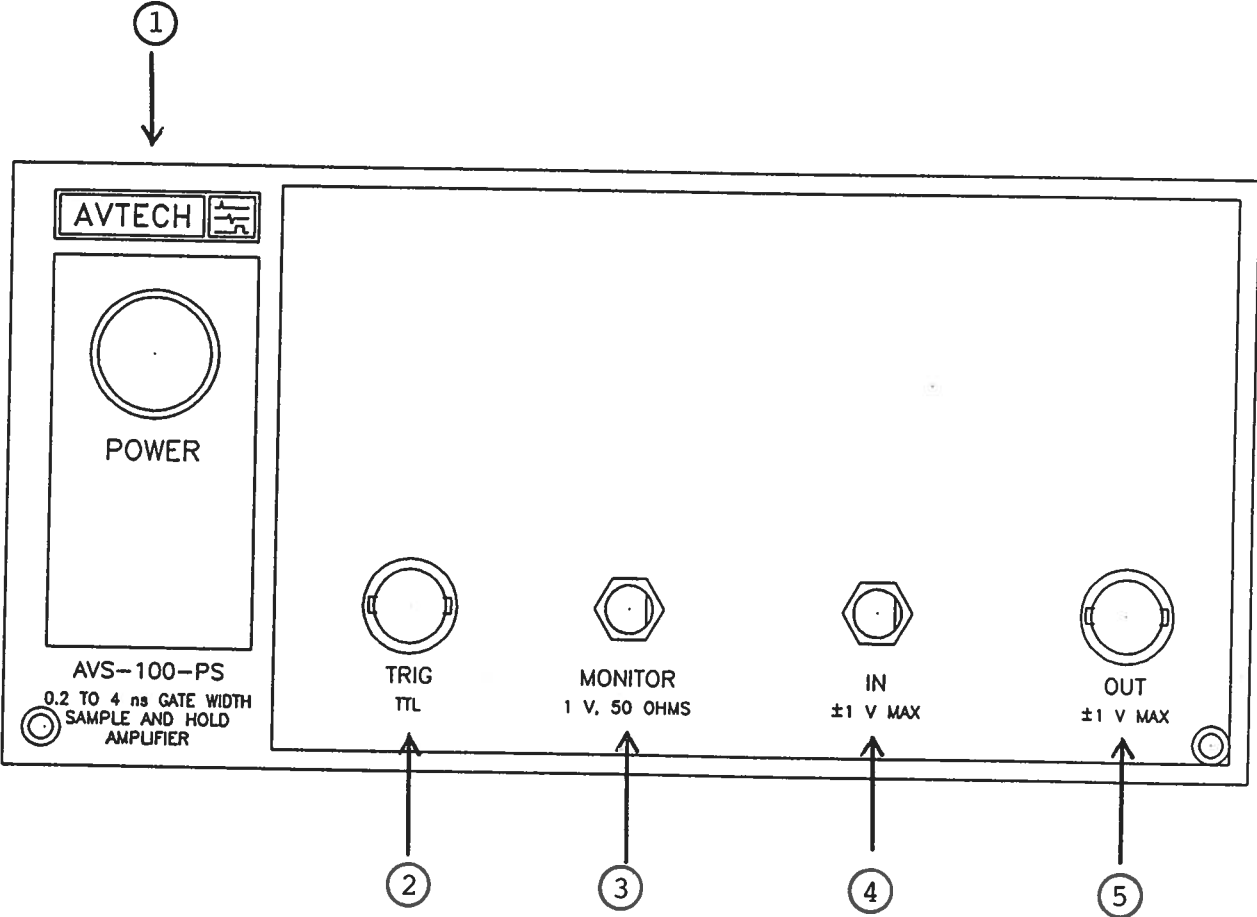

Note:

The unit is shipped with the gate width set at 200 ps and the GAIN control adjusted to provide unity gains.

- (1) ON-OFF Switch. Applies prime power to all stages.
- (2) TRIGGER. BNC connector to which TTL level 50 ns to 1.0 us trigger pulse is applied to activate sampler. Sample is taken 35.5 ns after the leading edge of the input TRIGGER pulse.
- (3) M (MONITOR) Output. SMA connector provides a +1 volt replica of the sample pulse to a fifty ohm load. The width of the M output pulse is controlled by the rear panel PW control and is equal to the width of the sample pulse which operates the sampling gate (0.2 to 4 ns). The M output appears 37.5 ns after the application of the TRIGGER pulse. The input signal is sampled 2 ns before the leading edge of the M output.
- (4) IN. SMA connector, fifty ohm input impedance to which signal to be sampled is applied. Max input  $\pm 1$  volt.
- (5) OUT. BNC connector connects 3 us wide pulse output to fifty ohm load. Output amplitude equals IN amplitude (rear panel GAIN control adjusts this). DC offset when IN amplitude equals zero set to zero using the rear panel OS control.

BACK PANEL CONTROLS

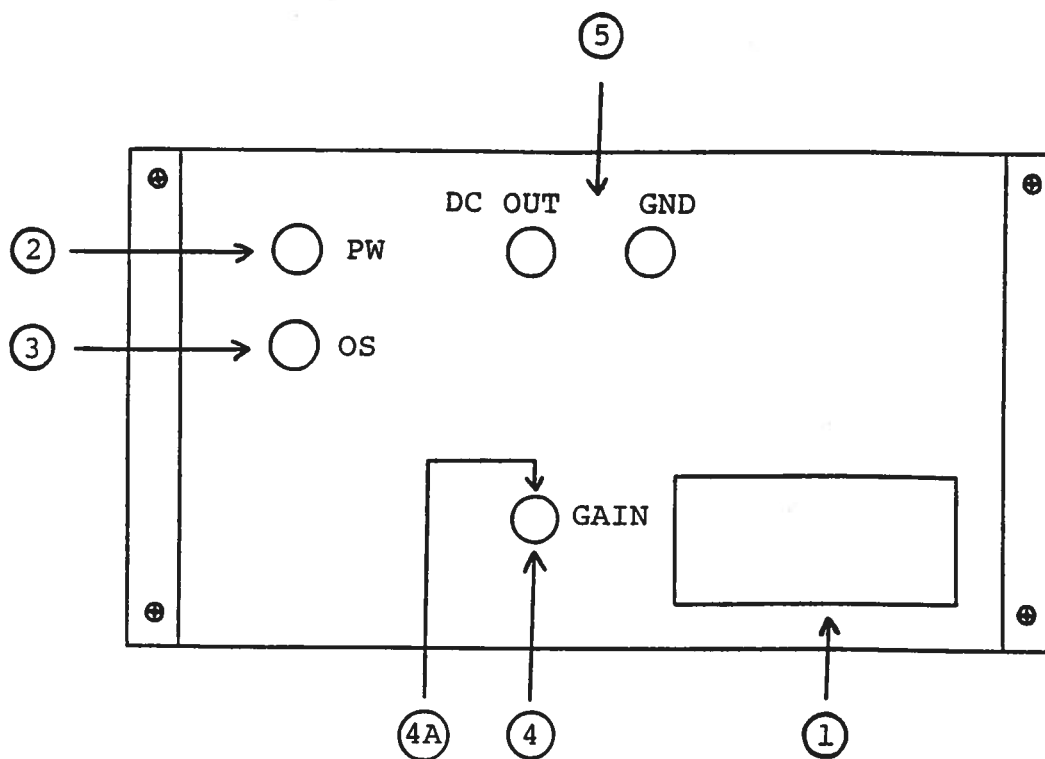

- (1) FUSED CONNECTOR, VOLTAGE SELECTOR. The detachable power cord is connected at this point. In addition, the removable cord is adjusted to select the desired input operating voltage. The unit also contains the main power fuse (0.25 A SB).
- (2) PW Control. A one turn control which varies the M (and sample) pulse width from 0.2 to 4 ns. Unit is shipped with the gate width set at 0.2 ns.
- (3) OS Control. A one turn offset control used to set OUT amplitude equal to zero when IN amplitude equals zero.
- (4) GAIN Control. A one turn control used to set OUT amplitude equal to IN amplitude. Note that this control has a locking screw on the top of the bearing (4A).
- (4A) LOCKING SCREW. 4-40 Allen Locking screw for GAIN control.
- (5) DC OUT. DC output amplitude equals IN amplitude. GAIN control used to set output amplitude equal to IN amplitude and OS control to set to zero when IN set to zero. Terminate in 1 K or higher impedance. Will withstand short-circuit load.

# TIMING WAVEFORMS

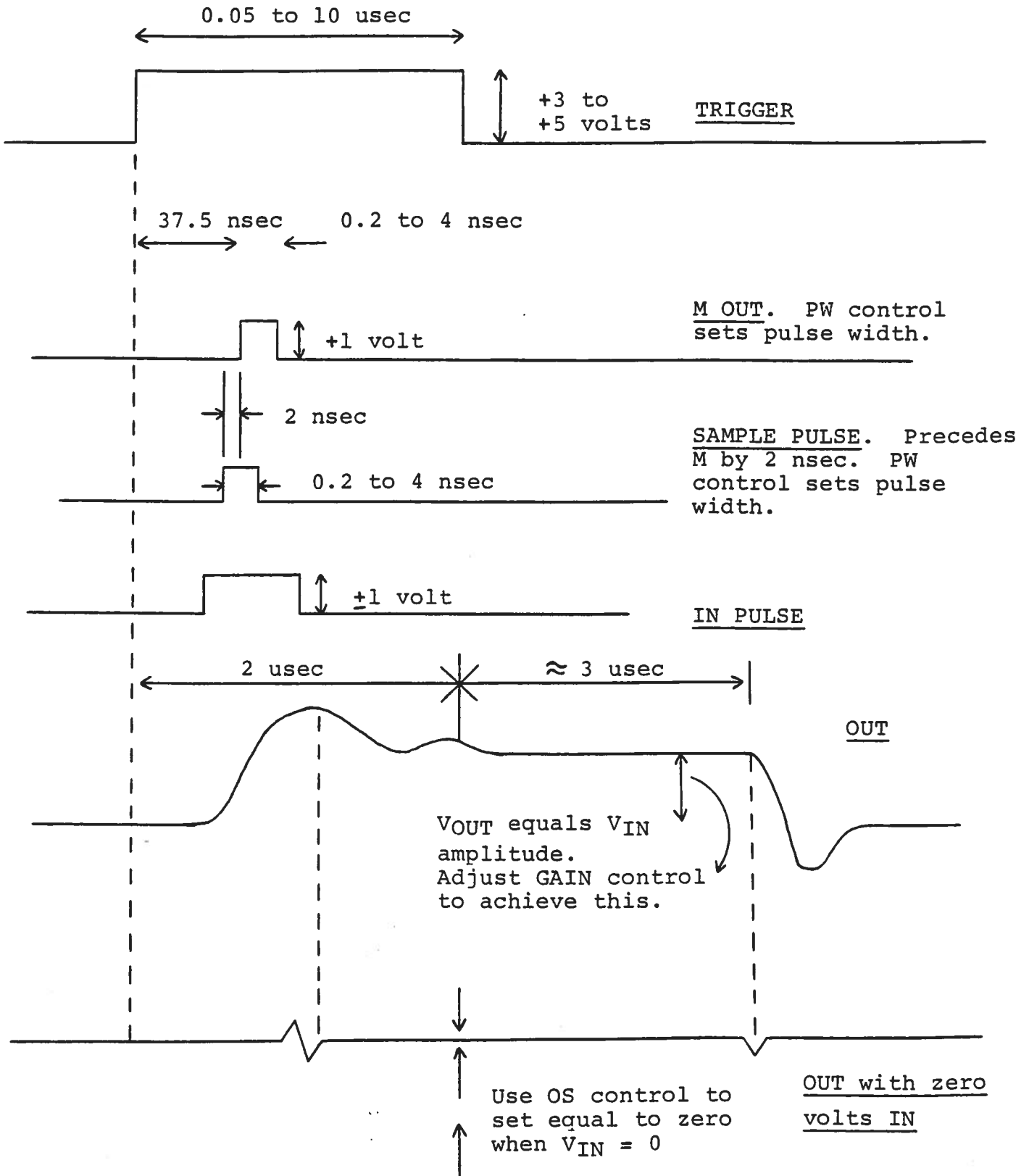

## TEST PROCEDURE AND OPERATION INSTRUCTIONS

- 1) It is recommended that the AVS-100-PS unit be first tested and calibrated using a DC input signal rather than a short pulse input signal so as to avoid the requirement of synchronizing the sampling pulse and the input pulse.
- 2) The following arrangement may be used for the DC test:



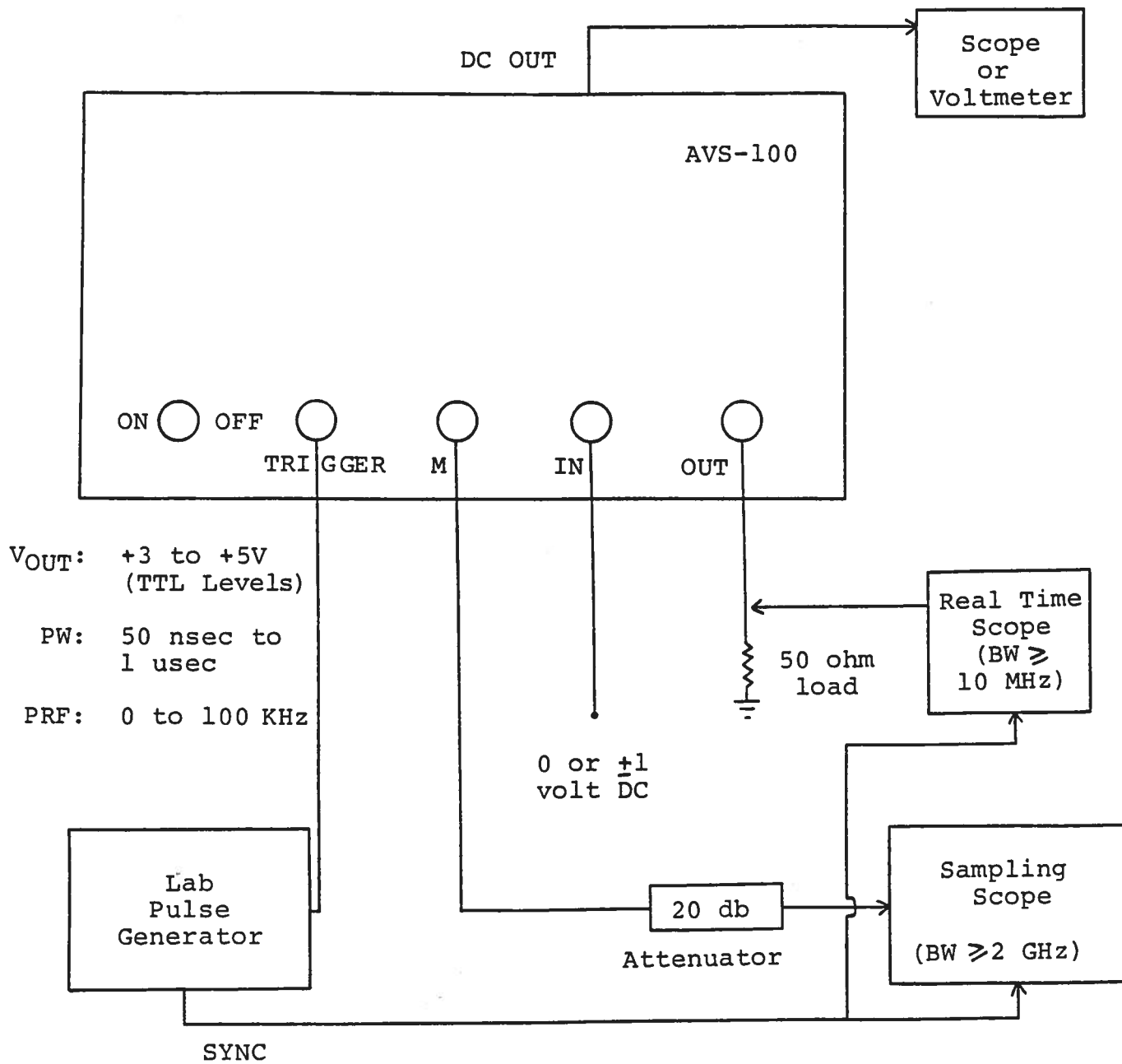

- 3) Apply prime power and with sampling scope and back panel PW control, set sampling pulse (or M) to desired width (see timing waveforms).
- 4) Apply 0 volts to IN input and use real time scope and OS control to set OUT level to approximately zero volts. (see timing waveforms).
- 5) Apply + or -1 volts to IN input and adjust GAIN control to obtain + or -1 volt at OUT point (see timing waveforms) and at the DC OUT point.
- 6) The unit is now calibrated. Note that if PW of sample pulse is changed, it will be necessary to reset the GAIN control. Increasing the PW increases the output amplitude thereby requiring that the GAIN control be turned counter clockwise to again set the OUT amplitude equal to the IN amplitude.
- 7) The unit may now be tested with a short pulse applied to the IN port. It should not be necessary to readjust the OS or GAIN controls. Note that if the amplitude of the input pulse is known (eg. determined using the sampling scope) the unit may be calibrated using only the short pulse rather than using the DC levels.
- 8) When operating properly, the pulse output should appear as a train of approx. 4 usec pulses having the same polarity and amplitude as the nanosecond pulses applied at the IN port. The base line between the pulses should be near zero and constant (or horizontal). If the base line between the pulses is not constant it may not be possible to calibrate the unit as previously described or the output amplitude may be a function of the PRF. To adjust the inter pulse base line, remove the instrument top cover by removing the four Phillips screws on the back panel of the instrument. The top cover may then be slid off exposing the module in the interior. With the unit triggered, the prime power on and the IN voltage set to zero adjust pots 5, 6, 7 and 8 on the module until the OUT voltage is near zero and constant. Note that only very minor adjustments of the pots should be necessary.

9) As the PW sample width is varied from 0.2 to 4.0 nsec, the OUT level during the 4 usec pulse out interval may vary and it may not be possible to zero using the rear panel OS control. In such cases, a minor change in the PW control may make a zero output possible. If this is not possible then minor adjustment to pots 1 and 2 on the sampler module can be made to establish a zero output.

10) For additional assistance:

Tel: (613) 226-5772

Fax: (613) 226-2802

AVS-100-PS BLOCK DIAGRAM

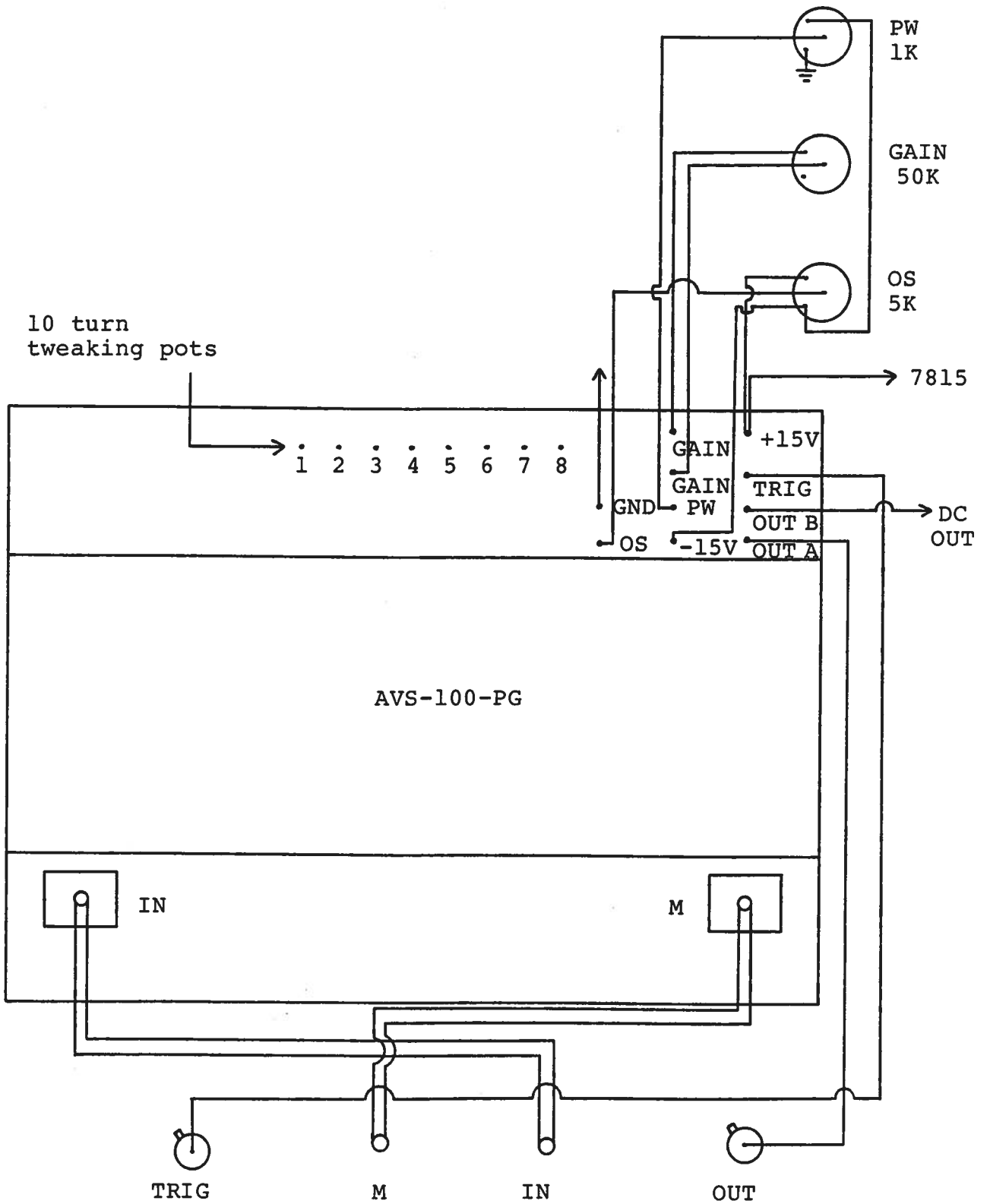

## SYSTEM DESCRIPTION

The AVS-100 comprises the following basic modules:

- 1) AVS-100-PG sampler
- 2) 110V 60 Hz to +15V power supply board

The modules are interconnected as shown in the preceding diagram.

The sampler attenuates the signal applied at the IN port and takes a 0.2 to 4 nsec wide sample of this signal. The resulting sample voltage is stored on a small capacitor which shunts a high impedance input amplifier. The capacitor is discharged to zero after 3.5 usec by a shunting switch. Variable gain output amplifiers boost the capacitor voltage so that the peak output voltage equals the amplitude of the voltage applied to the IN terminal of the AVS-100 unit.

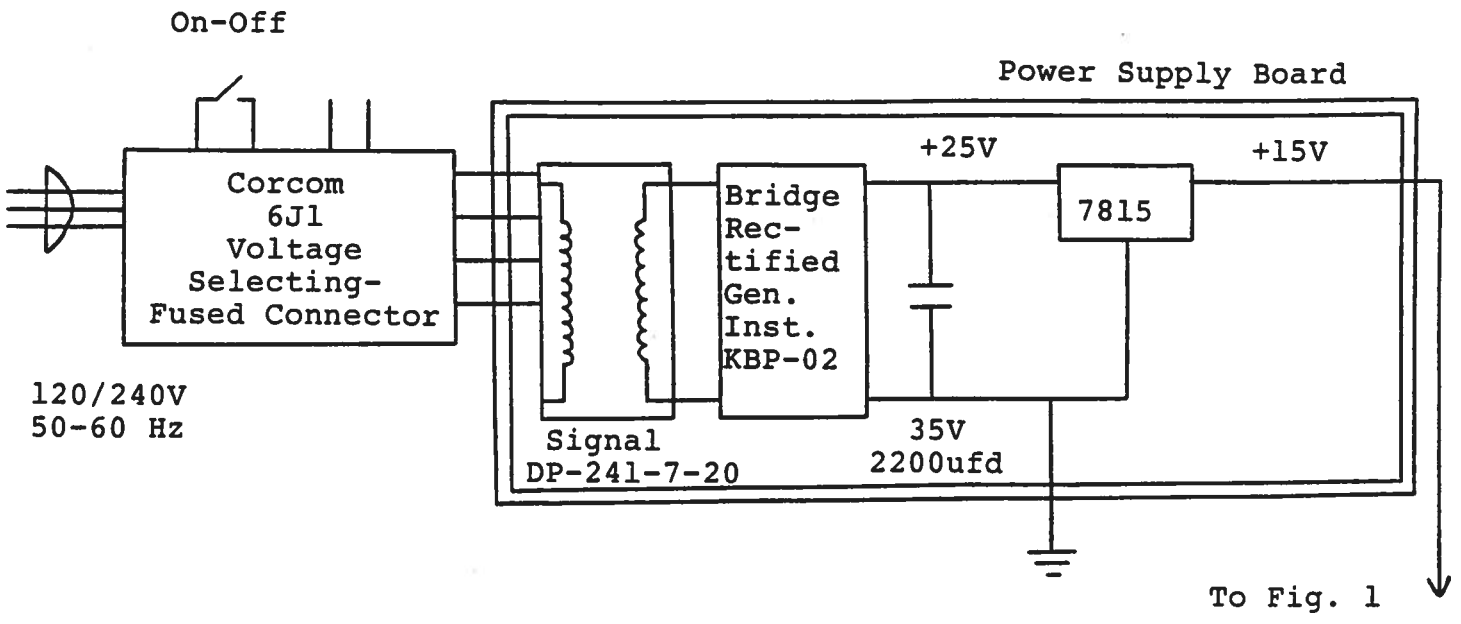

## POWER SUPPLY

The AVS-100 consists of one standard module and a power supply board which supplies +15 volts (600 mA max) to the modules. In the event that the unit malfunctions, remove the four Phillips screws on the back panel of the instrument. The top cover may then be slid off. Measure the voltage at the +15V pin of the PG module. If this voltage is substantially less than +15 volts, unsolder the line connecting the power supply board and PG module and connect a 50 ohm 10 W load to the power supply output. The voltage across this load should be about 15 V DC. If this voltage is substantially less than 15 volts the power supply board is defective and should be repaired or replaced. If the voltage is near +15V then see instructions in preceding section.

September 17/97

Disk: AVS

File: AVS100D.INS