



AVTECH ELECTROSYSTEMS LTD.

NANOSECOND WAVEFORM ELECTRONICS
SINCE 1975

P.O. BOX 265
OGDENSBURG, NY
U.S.A. 13669-0265
TEL: (315) 472-5270
FAX: (613) 226-2802

TEL: 1-800-265-6681
FAX: 1-800-561-1970
U.S.A. & CANADA

BOX 5120 STN. F
OTTAWA, ONTARIO
CANADA K2C 3H4
TEL: (613) 226-5772
FAX: (613) 226-2802

INSTRUCTIONS

MODEL AVS-101 SAMPLE AND HOLD UNIT

S.N.:

WARRANTY

Avtech Electrosystems Ltd. warrants products of its manufacture to be free from defects in material and workmanship under conditions of normal use. If, within one year after delivery to the original owner, and after prepaid return by the original owner, this Avtech product is found to be defective, Avtech shall at its option repair or replace said defective item. This warranty does not apply to units which have been disassembled, modified or subjected to conditions exceeding the applicable specifications or ratings. This warranty is the extent of the obligation or liability assumed by Avtech with respect to this product and no other warranty or guarantee is either expressed or implied.

FRONT PANEL CONTROLS

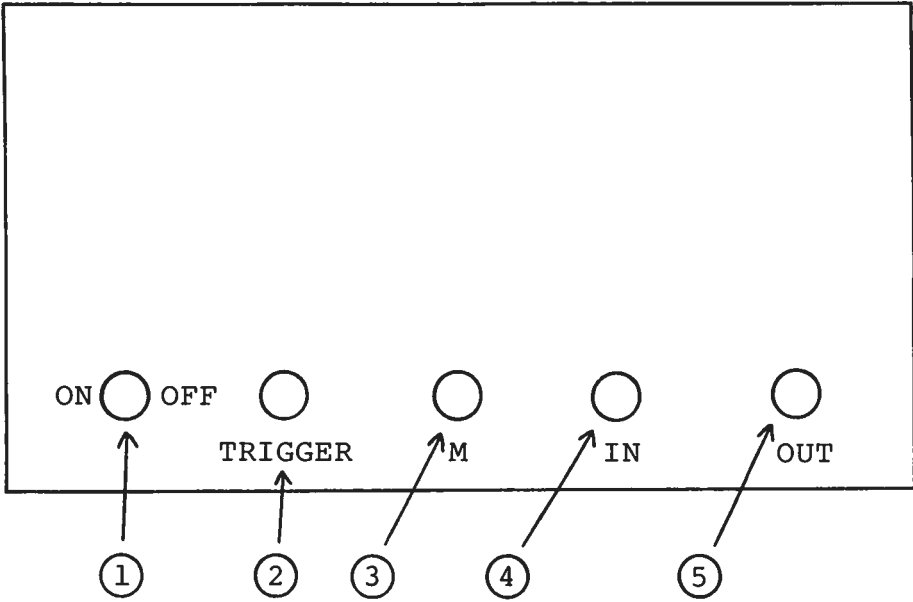

- (1) ON-OFF Switch. Applies prime power to all stages.
- (2) TRIGGER. BNC connector to which TTL level 50 nsec to 1.0 usec trigger pulse is applied to activate sampler. Sample is taken 35.5 nsec after the leading edge of the input TRIGGER pulse.
- (3) M (MONITOR) Output. BNC connector provides a +1 volt replica of the sample pulse to a fifty ohm load. The width of the M output pulse is controlled by the back panel PW control and is equal to the width of the sample pulse which operates the sampling gate (4 to 20 nsec). The M output appears 37.5 nsec after the application of the TRIGGER pulse. The input signal is sampled 2 nsec before the leading edge of the M output.
- (4) IN. BNC connector, fifty ohm input impedance to which signal to be sampled is applied. Max input ± 1 volt.
- (5) OUT. BNC connector connects 3 usec wide pulse output to fifty ohm load. Output amplitude equals IN amplitude (GAIN control adjusts this). DC offset when IN amplitude equals zero set to zero using OS control.

BACK PANEL CONTROLS

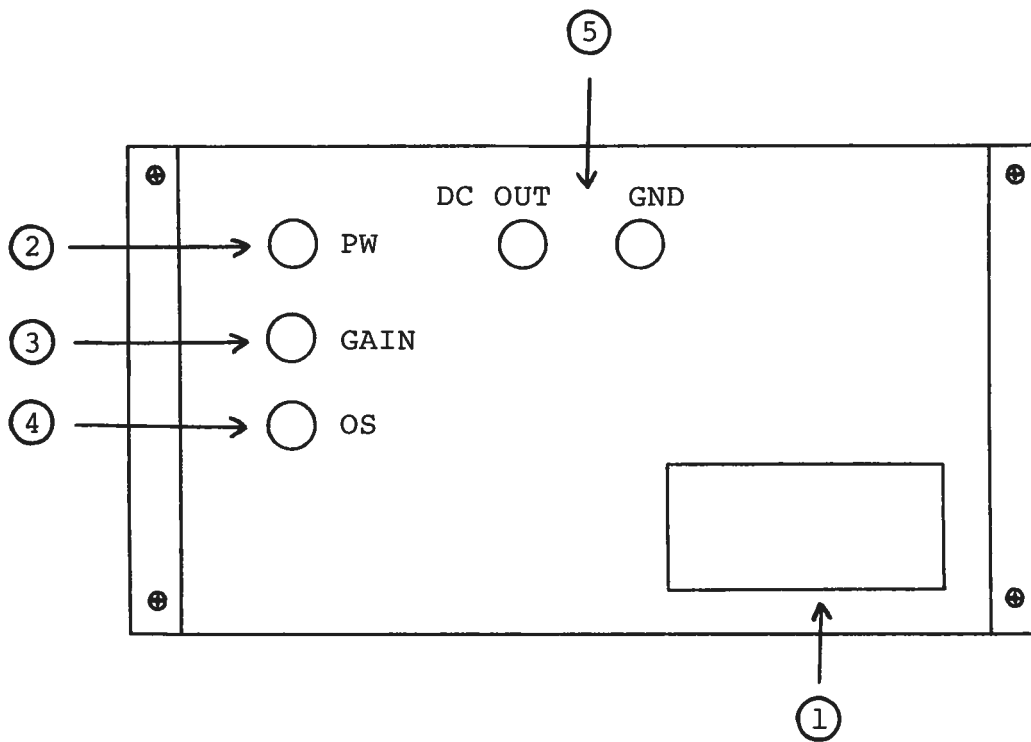

- (1) FUSED CONNECTOR, VOLTAGE SELECTOR. The detachable power cord is connected at this point. In addition, the removable cord is adjusted to select the desired input operating voltage. The unit also contains the main power fuse.
- (2) PW Control. A one turn control which varies the M (and sample) pulse width from 4 to 20 nsec.
- (3) GAIN Control. A one turn control used to set OUT amplitude equal to IN amplitude.
- (4) OS Control. A one turn offset control used to set OUT amplitude equal to zero when IN amplitude equals zero.
- (5) DC OUT. DC output amplitude equals IN amplitude. GAIN control used to set output amplitude equal to IN amplitude and OS control to set to zero when IN set to zero. Terminate in 1 K or higher impedance. Will withstand short-circuit load.

TIMING WAVEFORMS

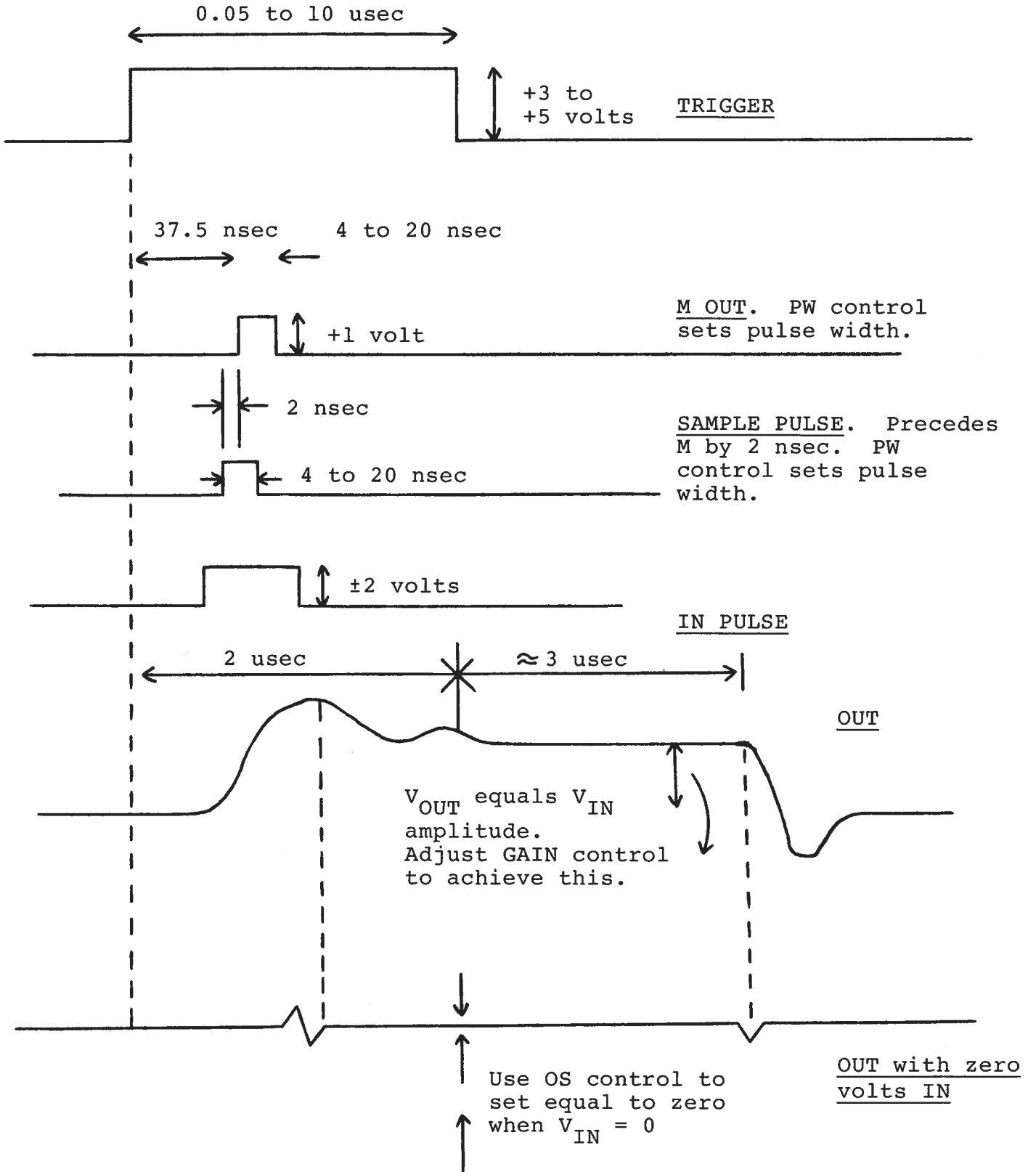

TEST PROCEDURE AND OPERATION INSTRUCTIONS

- 1) It is recommended that the AVS-101 unit be first tested and calibrated using a DC input signal rather than a short pulse input signal so as to avoid the requirement of synchronizing the sampling pulse and the input pulse.
- 2) The following arrangement may be used for the DC test:

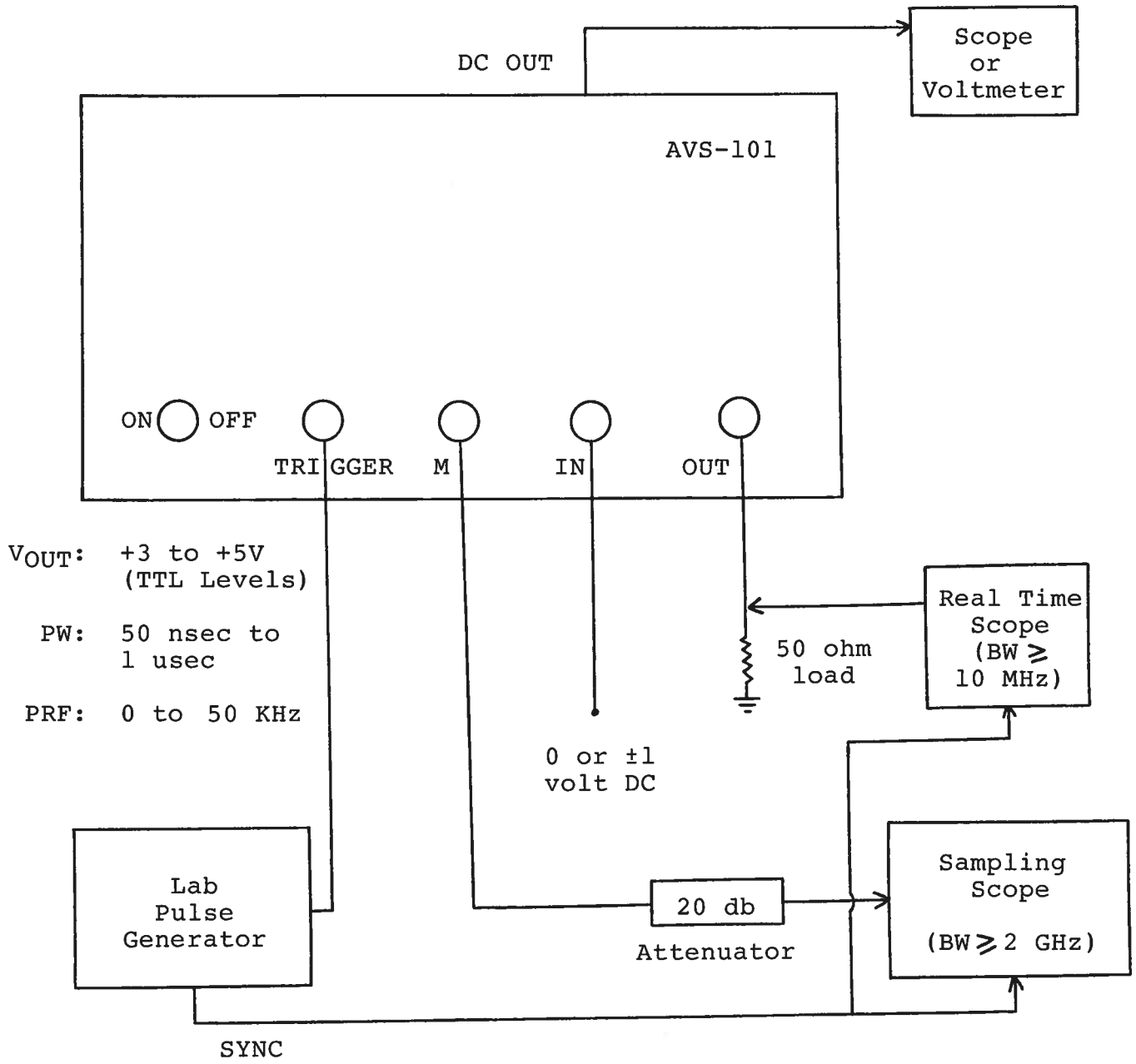

- 3) Apply prime power and with sampling scope and back panel PW control, set sampling pulse (or M) to desired width (see timing waveforms).
- 4) Apply 0 volts to IN input and use real time scope and OS control to set OUT level to approximately zero volts. (see timing waveforms).
- 5) Apply + or -1 volts to IN input and adjust GAIN control to obtain + or -1 volt at OUT point (see timing waveforms) and at the DC OUT point.
- 6) The unit is now calibrated. Note that if PW of sample pulse is changed, it will be necessary to reset the GAIN control. Increasing the PW increases the output amplitude thereby requiring that the GAIN control be turned counter clockwise to again set the OUT amplitude equal to the IN amplitude.
- 7) The unit may now be tested with a short pulse applied to the IN port. It should not be necessary to readjust the OS or GAIN controls. Note that if the amplitude of the input pulse is known (eg. determined using the sampling scope) the unit may be calibrated using only the short pulse rather than using the DC levels.
- 8) When operating properly, the pulse output should appear as a train of approx. 4 usec pulses having the same polarity and amplitude as the nanosecond pulses applied at the IN port. The base line between the pulses should be near zero and constant (or horizontal). If the base line between the pulses is not constant it may not be possible to calibrate the unit as previously described or the output amplitude may be a function of the PRF. To adjust the inter pulse base line, remove the instrument top cover by removing the four Phillips screws on the back panel of the instrument. The top cover may then be slid off exposing the 2 modules in the interior. With the unit triggered, the prime power on and the IN voltage set to zero adjust the four locking pots on the AMPLIFIER module (1 to 4) until the OUT voltage is near zero and constant. Note that only very minor adjustments of the pots should be necessary and take care to relock the locking pots.

7815

+15V

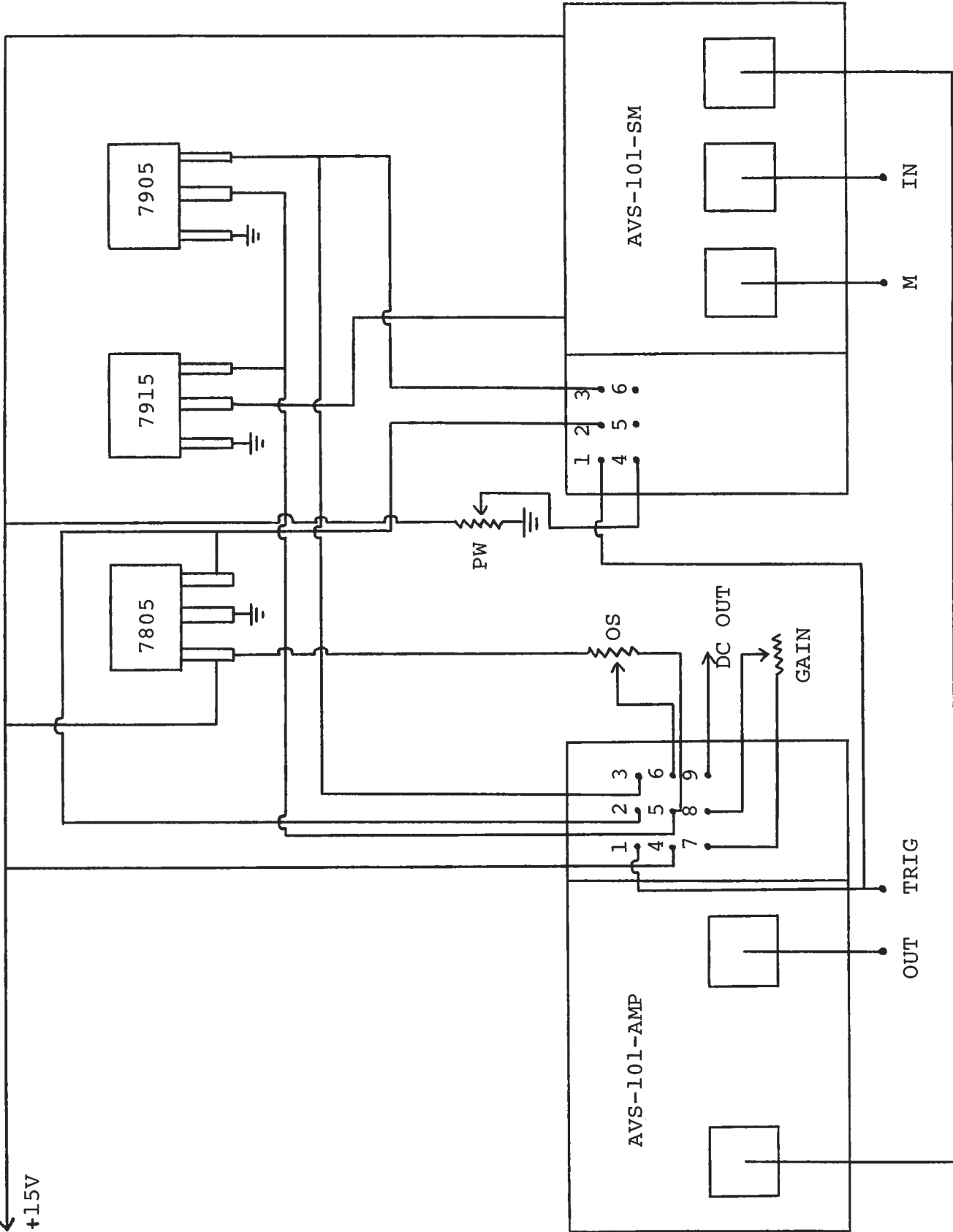

SYSTEM BLOCK DIAGRAM

SYSTEM DESCRIPTION

The AVS-101 comprises three basic modules:

- 1) AVS-101-SM sampler
- 2) AVS-101-AMP amplifier
- 3) 110V 60 Hz to +15V power supply board

The modules are interconnected as shown in the preceding diagram.

The sampler attenuates the signal applied at the IN port and takes a 4 to 20 nsec wide sample of this signal. The resulting sample voltage is stored on a small capacitor which shunts the high impedance input amplifier at the input of the AVS-101-AMP module. The capacitor is discharged to zero after 3.5 usec by a shunting switch. Variable gain output amplifiers boost the capacitor voltage so that the AVS-101-AMP peak output voltage equals the amplitude of the voltage applied to the IN terminal of the AVS-101 unit.

POWER SUPPLY

The AVS-101 consists of the two standard modules and a power supply board which supplies +15 volts (600 mA max) to the modules. In the event that the unit malfunctions, remove the four Phillips screws on the back panel of the instrument. The top cover may then be slid off. Measure the voltage at the +15V pin of the PG module. If this voltage is substantially less than +15 volts, unsolder the line connecting the power supply board and PG module and connect a 50 ohm 10 W load to the power supply output. The voltage across this load should be about 15 V DC. If this voltage is substantially less than 15 volts the power supply board is defective and should be repaired or replaced. If the voltage is near +15V then see instructions in preceding section.

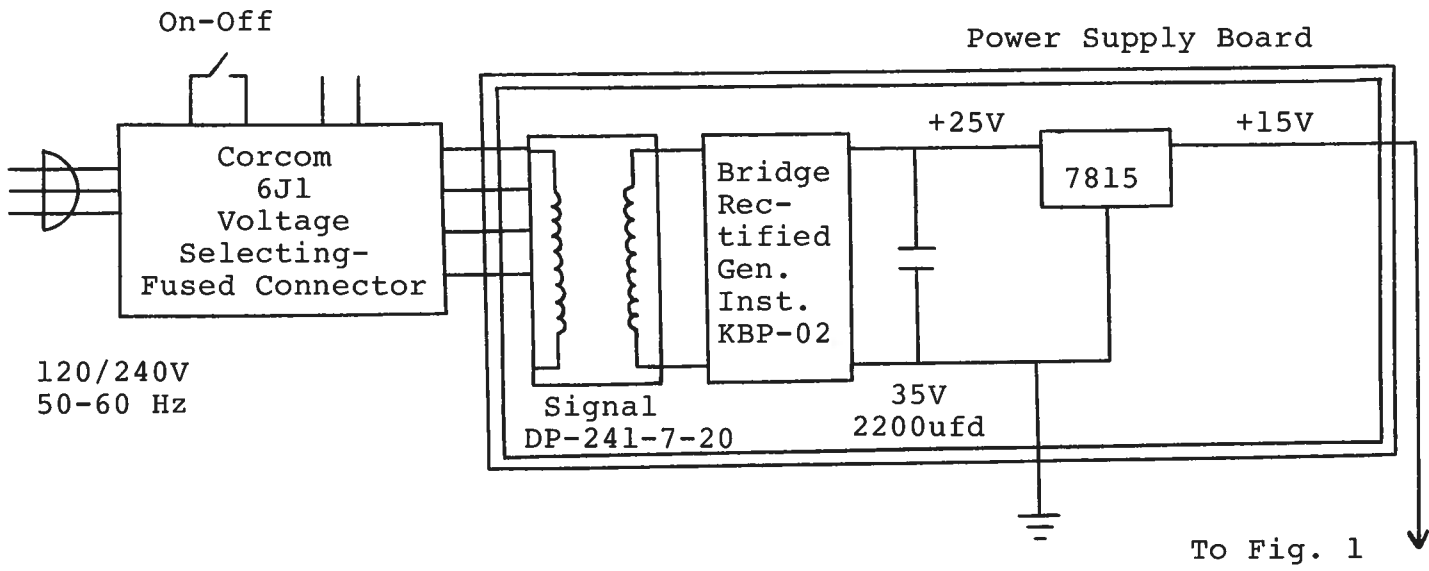

Schroff

03.01.85 Edition A

-M

-05

