



AVTECH ELECTROSYSTEMS LTD.

NANOSECOND WAVEFORM ELECTRONICS
SINCE 1975

P.O. BOX 265
OGDENSBURG, NY
U.S.A. 13669-0265
TEL: (315) 472-5270
FAX: (613) 226-2802

TEL: 1-800-265-6681
FAX: 1-800-561-1970
U.S.A. & CANADA

e-mail: info@avtechpulse.com

BOX 5120 STN. F
OTTAWA, ONTARIO
CANADA K2C 3H4
TEL: (613) 226-5772
FAX: (613) 226-2802

INSTRUCTIONS

MODEL AVX-D-PS PULSE GENERATOR

S.N. :

WARRANTY

Avtech Electrosystems Ltd. warrants products of its manufacture to be free from defects in material and workmanship under conditions of normal use. If, within one year after delivery to the original owner, and after prepaid return by the original owner, this Avtech product is found to be defective, Avtech shall at its option repair or replace said defective item. This warranty does not apply to units which have been disassembled, modified or subjected to conditions exceeding the applicable specifications or ratings. This warranty is the extent of the obligation or liability assumed by Avtech with respect to this product and no other warranty or guarantee is either expressed or implied.

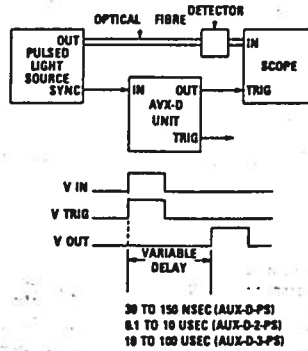
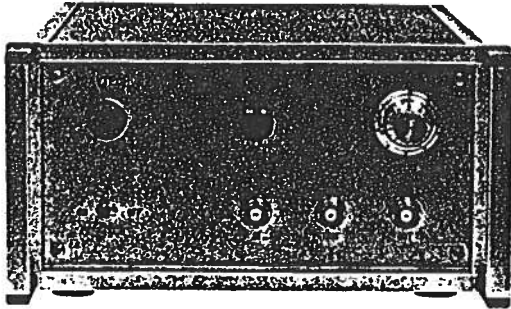

- 30 to 150 nsec delays
- 100 nsec to 10 usec delays
- 10 usec to 100 usec delays
- Jitter as low as ± 10 psec
- TTL signal levels
- Will drive 50 ohm loads

Three models in the AVX-D analog delay generator series feature low-jitter variable delays in the ranges of 30 nsec to 150 nsec (Model AVX-D-PS), 100 nsec to 10 usec (Model AVX-D-2-PS) and 10 usec to 100 usec (Model AVX-D-3-PS). Model AVX-D-PS offers a jitter of ± 10 psec while Model AVX-D-2-PS exhibits a jitter of ± 30 psec at the minimum delay setting and increasing to ± 60 psec at the maximum delay setting. The delay for Model AVX-D-3-PS is specified as ± 300 psec. All signals are TTL compatible and the output pulses will drive loads as low as 50 ohms. The IN trigger pulse in all models is split into an output TRIG pulse (equal to the width of the IN pulse and delayed by about 20 nsec) and an OUT pulse having a fixed width of about 250 nsec. The delay between the leading edges of the IN and OUT pulse in Model AVX-D-PS (30 to 150 nsec) is controlled via a one turn control while

the delay in Model AVX-D-2-PS and AVX-D-3-PS (100 nsec to 10 usec and 10 usec to 100 usec, respectively) are controlled by 10 turn dial reading pots and range switches. Model AVX-D-PS is also available with an optional electronic delay control (0 to +10 volts).

The input and output waveforms for the various models are illustrated above along with an example of a possible application where the delay generator is used to compensate for the propagation delay through an optical fibre.

The units will operate at PRF as high as 1.0 MHz provided the delay setting does not exceed one half of the period of the PRF. Units with the -PS suffix require 110/220V (switchable), 50–60 Hz prime power while units without the -PS suffix (ie. modules) require +15 V DC prime power.

Model:	AVX-D-PS ¹ AVX-D	AVX-D-2-PS ¹ AVX-D-2	AVX-D-3-PS ¹ AVX-D-3
Delay range ² :	30 nsec to 150 nsec	100 nsec to 10 usec (3 position range switch)	10 usec to 100 usec (6 position range switch)
Jitter: (EXT TRIG IN to Pulse OUT)	± 10 psec	± 30 psec min to ± 60 psec max	± 300 psec
Output amplitude:	+5 V (TTL) will drive 50 ohm loads		
Trigger required: (Modules and -PS units)	+5 volt, 50 to 500 nsec (TTL)		
OUT pulse width:	250 nsec		
TRIG PW:	Equals input PW		
PRF:	0 to 1 MHz	0 to 1 MHz (50% max duty cycle)	0 to 50 KHz (50% max duty cycle)
Connectors: -PS: OUT TRIG IN Modules: OUT TRIG IN POWER	BNC BNC BNC SMA SMA SMA Solder terminals		
Power requirement: -PS: Modules:	120/240 volts (switchable) 50–60 Hz +15 volt, 200 mA		
Dimensions (IN): -PS: Modules:	4 x 8 x 12 1.7 x 2.6 x 4.2		

- 1) -PS suffix indicates line powered instrument requiring external trigger. No suffix indicates miniature module requiring DC power and external trigger. (See page 4 for additional details of the basic instrument formats).
- 2) For electronic control (0 to +10V) of delay in Models AVX-D or AVX-D-PS suffix model No. with -ED.

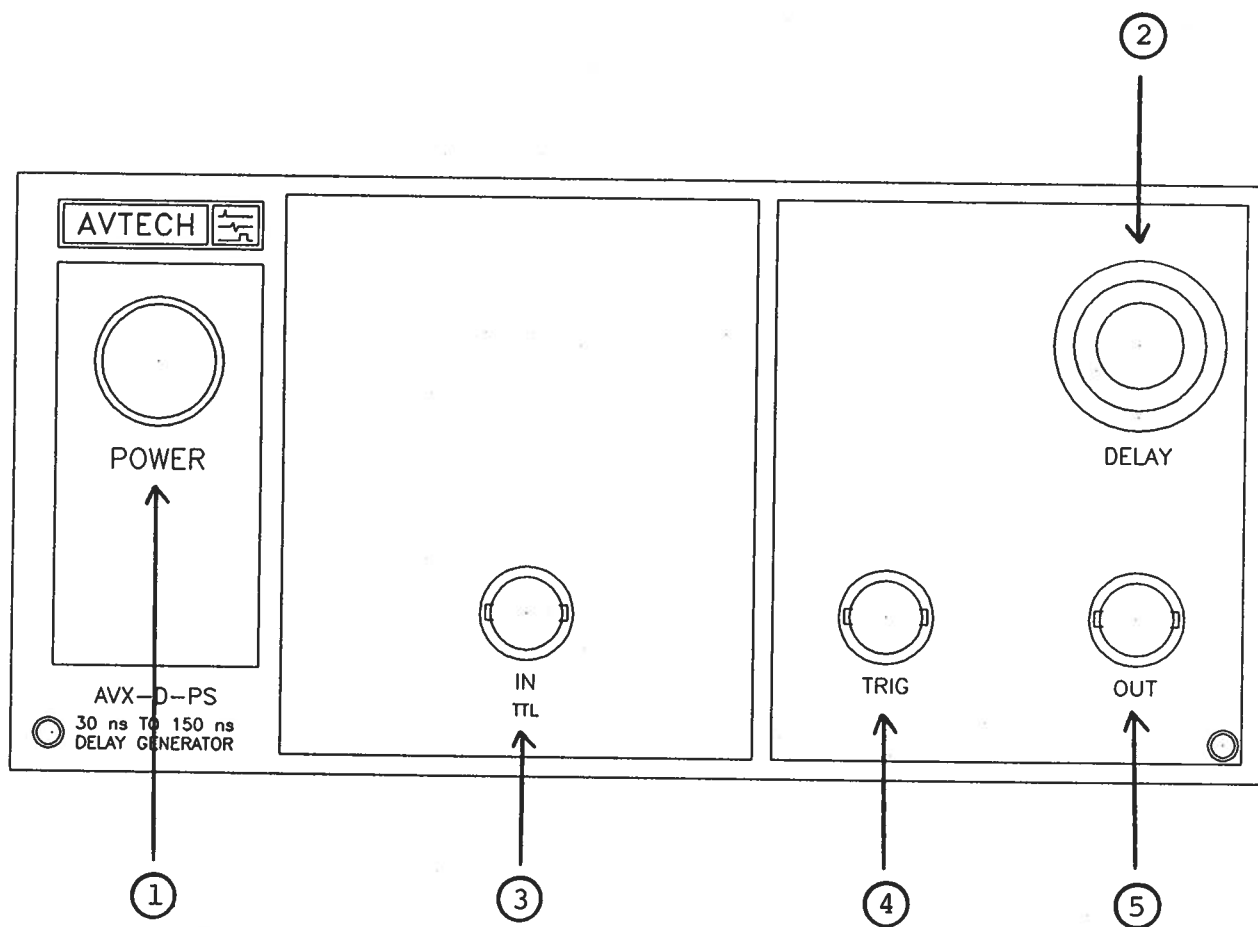

Fig. 1

FRONT PANEL CONTROLS

- (1) ON-OFF Switch. Applies basic prime power to all stages.
- (2) DELAY Control. Controls the relative delay between the output pulse provided at OUT (5) and IN (3). This delay is variable over the range of 30 to about 150 ns.
- (3) IN. Apply TTL input at this terminal (PW > 50 ns).
- (4) TRIG. Replica of IN pulse delayed by 30 ns appears here. Will drive 50 Ohms.
- (5) OUT. +5 Volt output to 50 Ohms. This output is delayed 30 to 150 ns with respect to the IN pulse.

Fig. 2

BACK PANEL CONTROLS

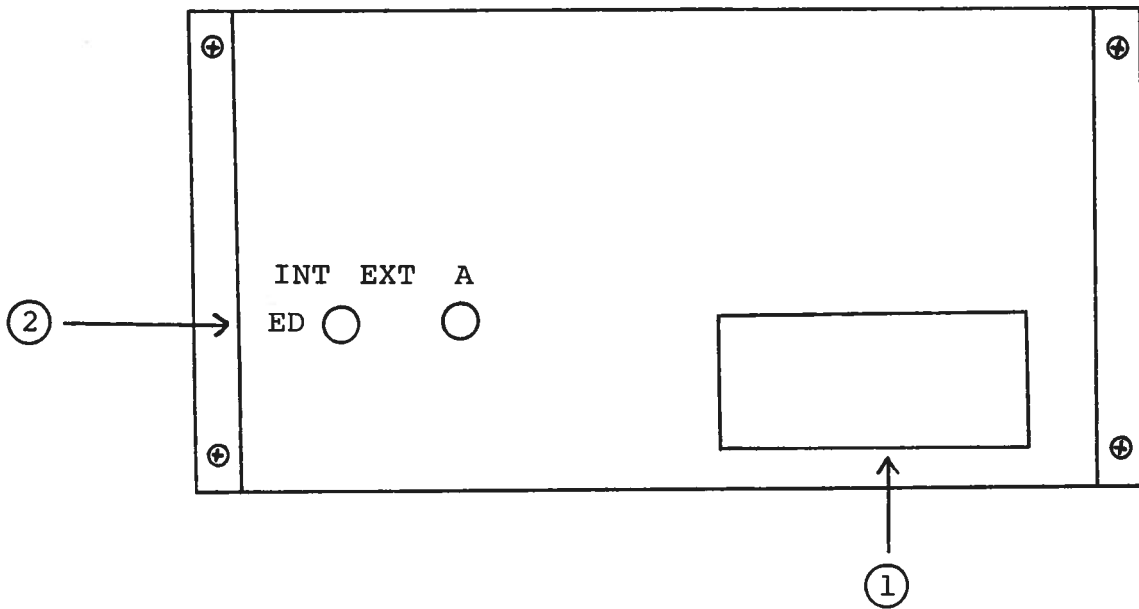

- (1) FUSED CONNECTOR, VOLTAGE SELECTOR. The detachable power cord is connected at this point. In addition, the removable cord is adjusted to select the desired input operating voltage. The unit also contains the main power fuse (0.25 A SB).
- (2) To voltage control the delay, set the switch in the EXT position and apply 0 to +10V to the "A" BNC connector ($R_{IN} \geq 10K$). (option).

SYSTEM BLOCK DIAGRAM AND REPAIR PROCEDURE

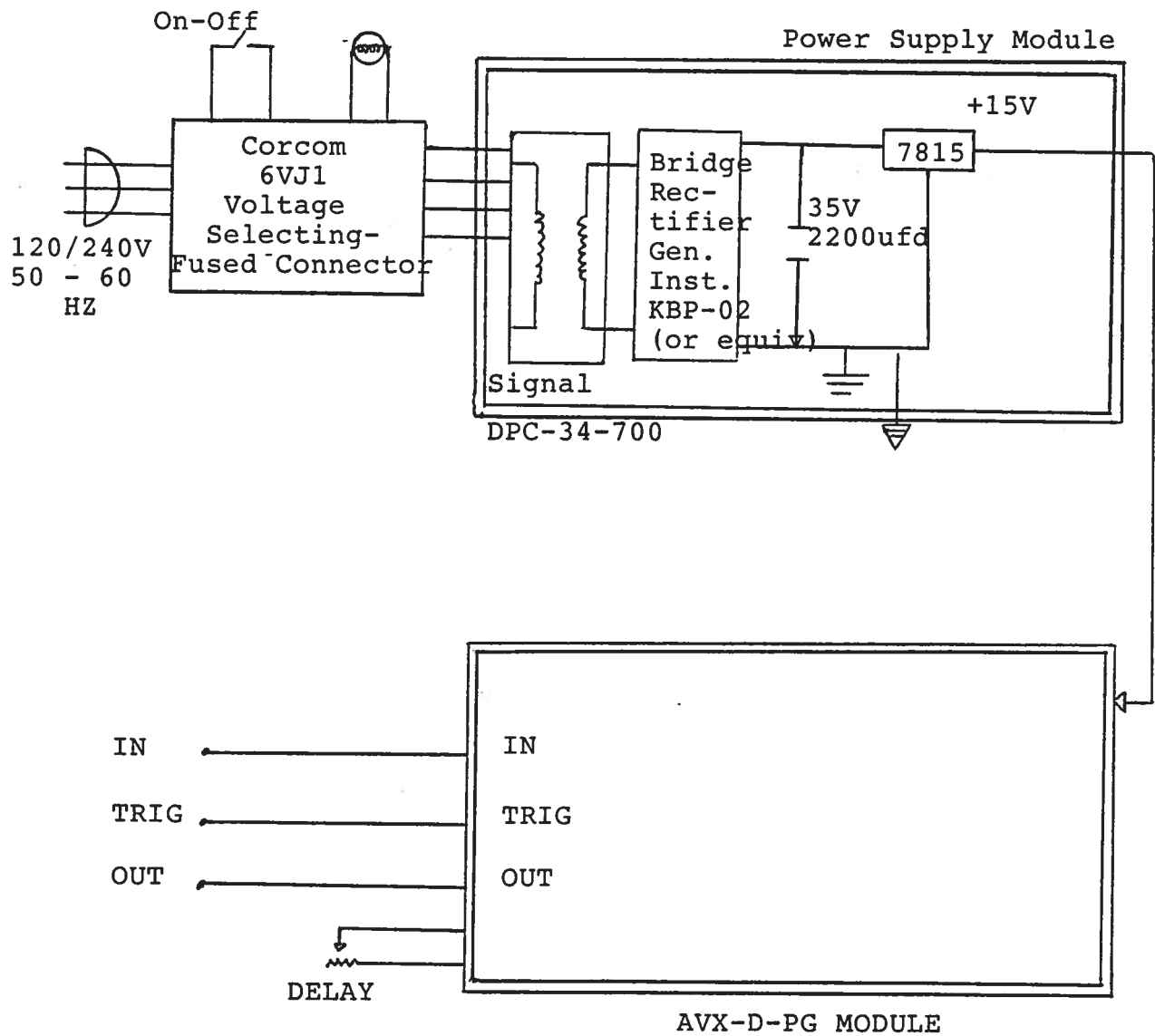

SYSTEM DESCRIPTION AND REPAIR PROCEDURE

The AVX-D-PS consists of a delay generator module (AVX-D-PG) and a power supply board which supplies +15 Volts (600 mA max) to the delay generator module. In the event that the AVX-D unit malfunctions, remove the instrument cover by removing the four Phillips screws on the back panel. The top cover may then be slid off. Measure the voltage at the +15V pin of the PG module. If this voltage is substantially less than +15 Volts, unsolder the line connecting the power supply and PG modules and connect 50 Ohm 10 W load to the PS output. The voltage across this load should be about +15V DC. If this voltage is substantially less than 15 Volts the PS module is defective and should be repaired or replaced. If the voltage across the resistor is near 15 Volts, then the PG module should be replaced or repaired. The sealed PG module must be returned to Avtech for repair (or replacement).

Feb. 7/97

edition C

-ED

Disk: AVX-D, AVX-F

Name: AVXDPSC.INS