



AVTECH ELECTROSYSTEMS LTD.

NANOSECOND WAVEFORM ELECTRONICS
SINCE 1975

P.O. BOX 265
OGDENSBURG, NY
U.S.A. 13669-0265
TEL: (315) 472-5270
FAX: (613) 226-2802

TEL: 1-800-265-6681
FAX: 1-800-561-1970
U.S.A. & CANADA

e-mail: info@avtechpulse.com

BOX 5120 STN. F
OTTAWA, ONTARIO
CANADA K2C 3H4
TEL: (613) 226-5772
FAX: (613) 226-2802

INSTRUCTIONS

MODEL AVX-D-2-PS DELAY GENERATOR

S.N. :

WARRANTY

Avtech Electrosystems Ltd. warrants products of its manufacture to be free from defects in material and workmanship under conditions of normal use. If, within one year after delivery to the original owner, and after prepaid return by the original owner, this Avtech product is found to be defective, Avtech shall at its option repair or replace said defective item. This warranty does not apply to units which have been disassembled, modified or subjected to conditions exceeding the applicable specifications or ratings. This warranty is the extent of the obligation or liability assumed by Avtech with respect to this product and no other warranty or guarantee is either expressed or implied.

SPECIFICATIONS

MODEL AVX-D-2-PS

Model designation: AVX-D-2-PS

Delay range: 100 ns to 10 us
Low range: 30 ns to 100 ns
Med. range: 100 ns to 1 us
High range: 1 us to 10 us

10 turn DL pot control
determines delay within each
range.

PRF range: 0 to 1 MHz.
Note that at given PRF, max
delay cannot exceed one half
of period of PRF.

Jitter: ± 10 ps at min DELAY to be
confirmed using AVH-S-1 130
ps impulse generators and
sampling scope display.
Jitter increases to ± 60 ps at
maximum delay.

Input PW: 50 to 500 ns

Output PW: 200 to 300 ns

Trig. PW: Equals input PW

Prop delay, IN to
TRIG port: ≤ 10 ns

Signal amplitudes: TTL levels;
Outputs will drive 50 Ohm loads

Power requirements: 110/220V, 50-60 Hz

Connectors: BNC

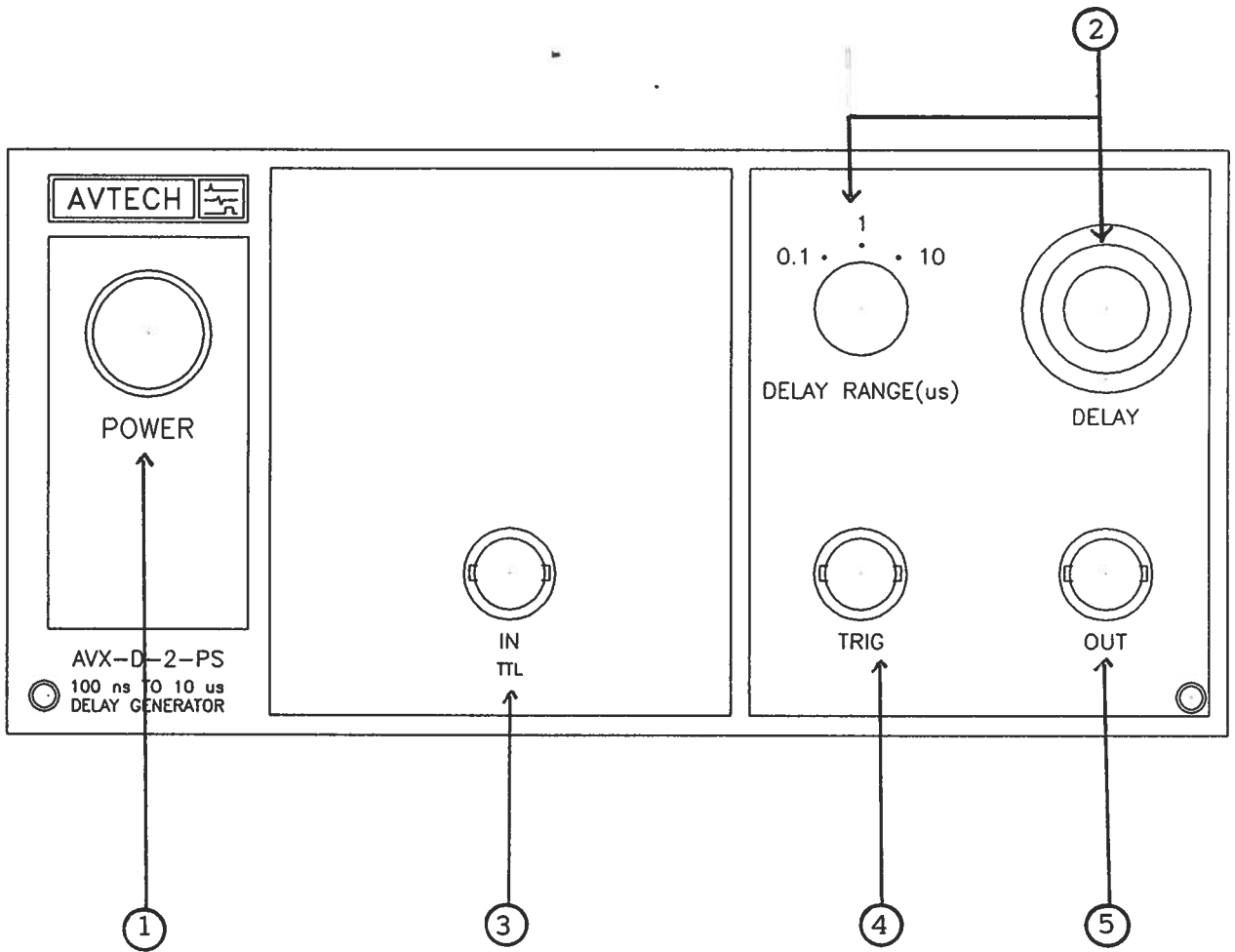

Fig. 1

FRONT PANEL CONTROLS

- (1) ON-OFF Switch. Applies basic prime power to all stages.
- (2) DELAY Control. Controls the relative delay between the output pulse provided at OUT (5) and IN (3). This delay is variable over the range of 30 ns to about 10 us as follows:
 - 30 ns to 100 ns
 - 100 ns to 1.0 us
 - 1.0 us to 10 ns
- (3) IN. Apply TTL input at this terminal (PW > 50 ns).
- (4) TRIG. Replica of IN pulse delayed by 30 ns appears here. Will drive 50 Ohms.
- (5) OUT. +5 Volt output to 50 Ohms. This output is delayed 30 ns to 10 us with respect to the IN pulse.

Fig. 2

BACK PANEL CONTROLS

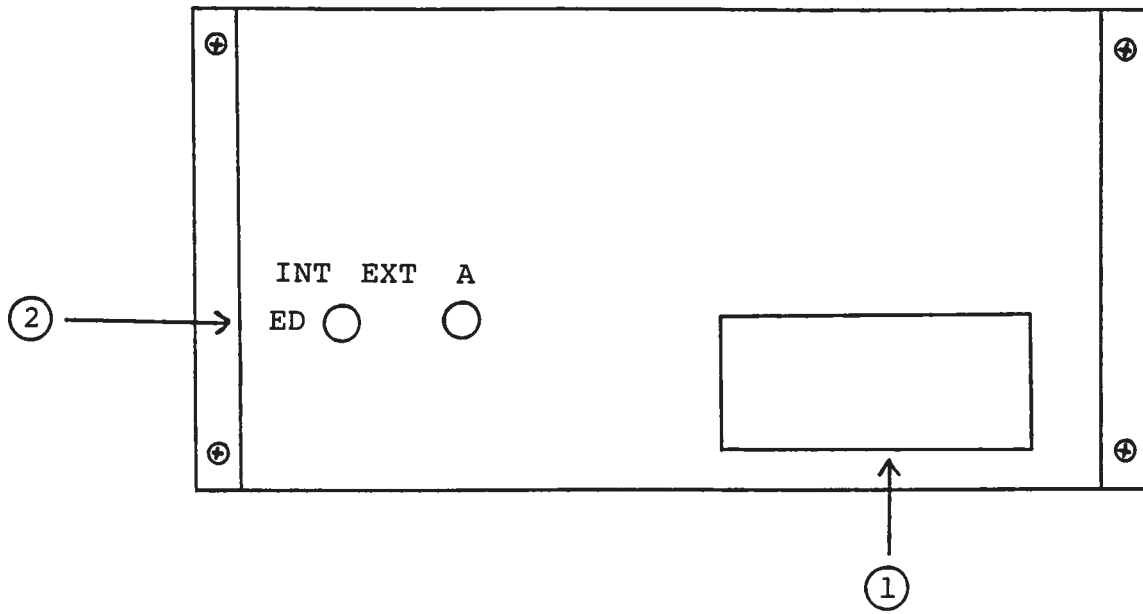

- (1) FUSED CONNECTOR, VOLTAGE SELECTOR. The detachable power cord is connected at this point. In addition, the removable cord is adjusted to select the desired input operating voltage. The unit also contains the main power fuse (0.25 A SB).
- (2) To voltage control the delay, set the switch in the EXT position and apply 0 to +10V to the "A" BNC connector ($R_{IN} \geq 10K$). (option).

MODEL AVX-D-2

JITTER AND DELAY TEST ARRANGEMENT

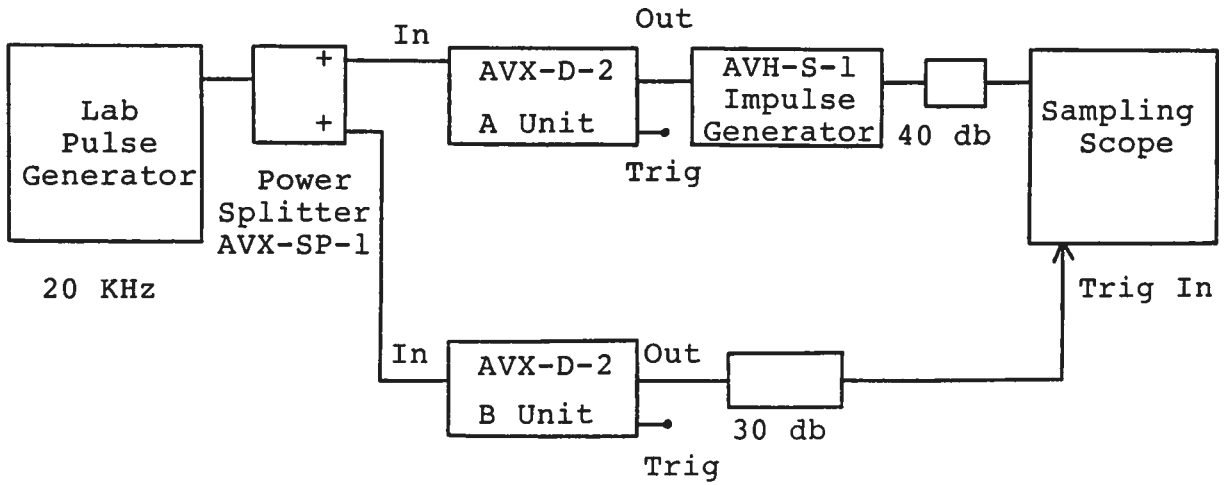

- 1) A worse-case jitter test of the AVX-D-2 unit was conducted using the above arrangement. The use of two delay generators serves to:
 - a) Aggravate the jitter since the resultant jitter is the consequence of two units.
 - b) Allow triggering of the sampling scope with long delays (eg. 10 us) on the AVX-D-2 units.
- 2) The delays of the A and B units should be such that the time base of the sampling scope is triggered slightly ahead (eg. 20-100 ns) of the application of the impulse to the vertical amplifier.
- 3) The photos on the following sheet illustrates the AVH-S-1 output waveform for the following three cases:
 - a) No delay, i.e. AVX-D-2 A and B units removed.
 - b) Delay of about 9 us.
 - c) Delay of about 2 us.
 - d) Delay of about 0.4 us.
- 4) The AVX-D-2 delay can be calibrated by means of a real time scope monitoring the time delay between the IN (or TRIG) and OUT ports.

JITTER TEST 12316

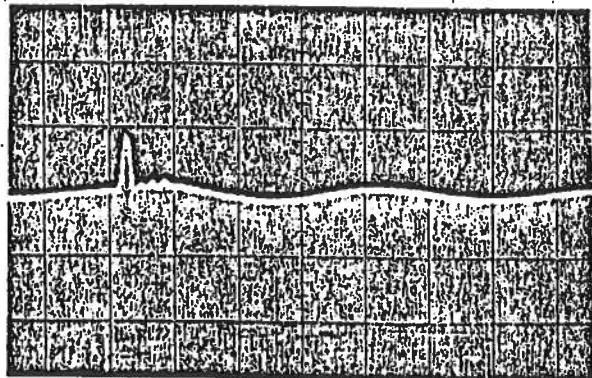
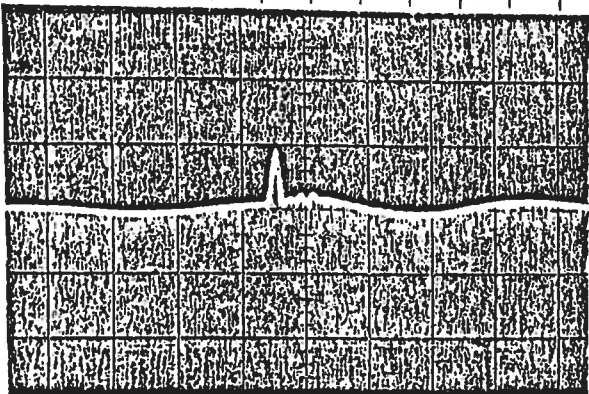
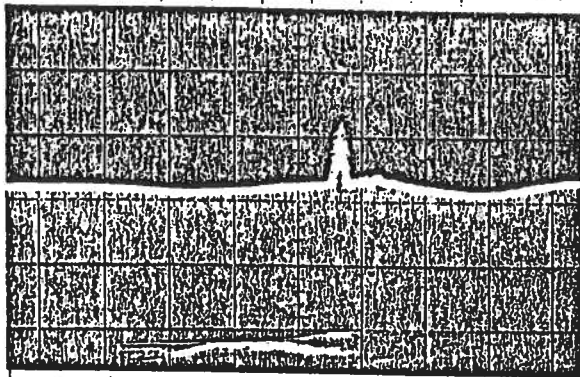
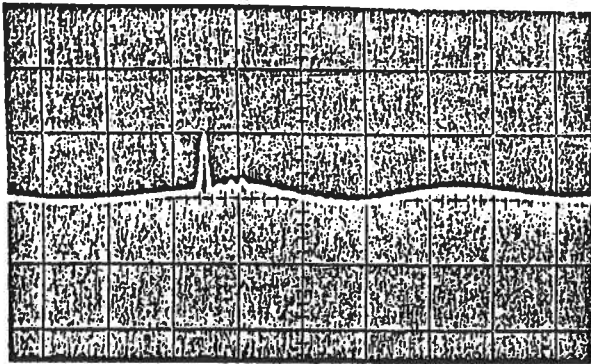

a) AVH-5-1 OUTPUT
NO DELAY,
LE NO AVX-10-2
UNITS

b) 9 nsec
DELAY

c) 2 nsec
DELAY

d) 0.4 nsec
DELAY

ALL PHOTOS
1.0 nsec/DIV
10 VOLTS/DIV
20 KHZ.

MODEL AVX-D-2

LONG TERM DRIFT TEST ARRANGEMENT

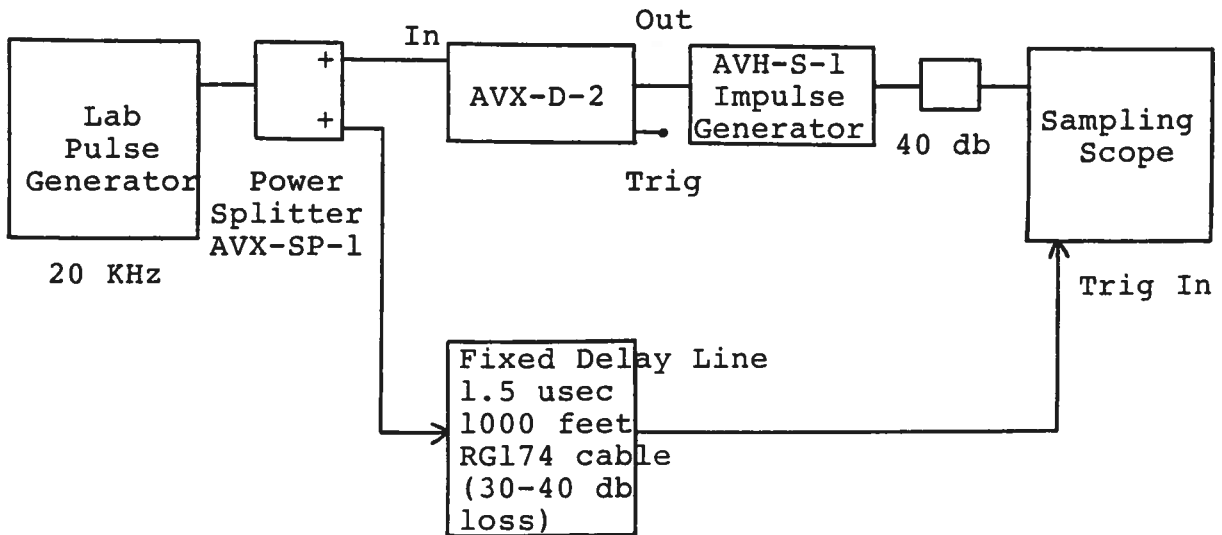

Following a warm-up period of 5 minutes, the AVX-D-2 delay is constant within ± 2 ns

SYSTEM DESCRIPTION AND REPAIR PROCEDURE

The AVX-D-2-PS consists of a pulse delay module (AVX-D-2-PG) and a power supply board which supplies +15 Volts (600 mA max) to the pulse generator module. In the event that the unit malfunctions, remove the instrument cover by removing the four Phillips screws on the back of the unit. The top lid may then be slid off. Measure the voltage at the +15V pin of the PG module. If this voltage is substantially less than +15 Volts, unsolder the line connecting the power supply and PG modules and connect 50 Ohm 10 W load to the PS output. The voltage across this load should be about +15V DC. If this voltage is substantially less than 15 Volts the PS module is defective and should be repaired or replaced. If the voltage across the resistor is near 15 Volts, then the PG module should be replaced or repaired. The sealed PG module must be returned to Avtech for repair (or replacement).

SYSTEM BLOCK DIAGRAM

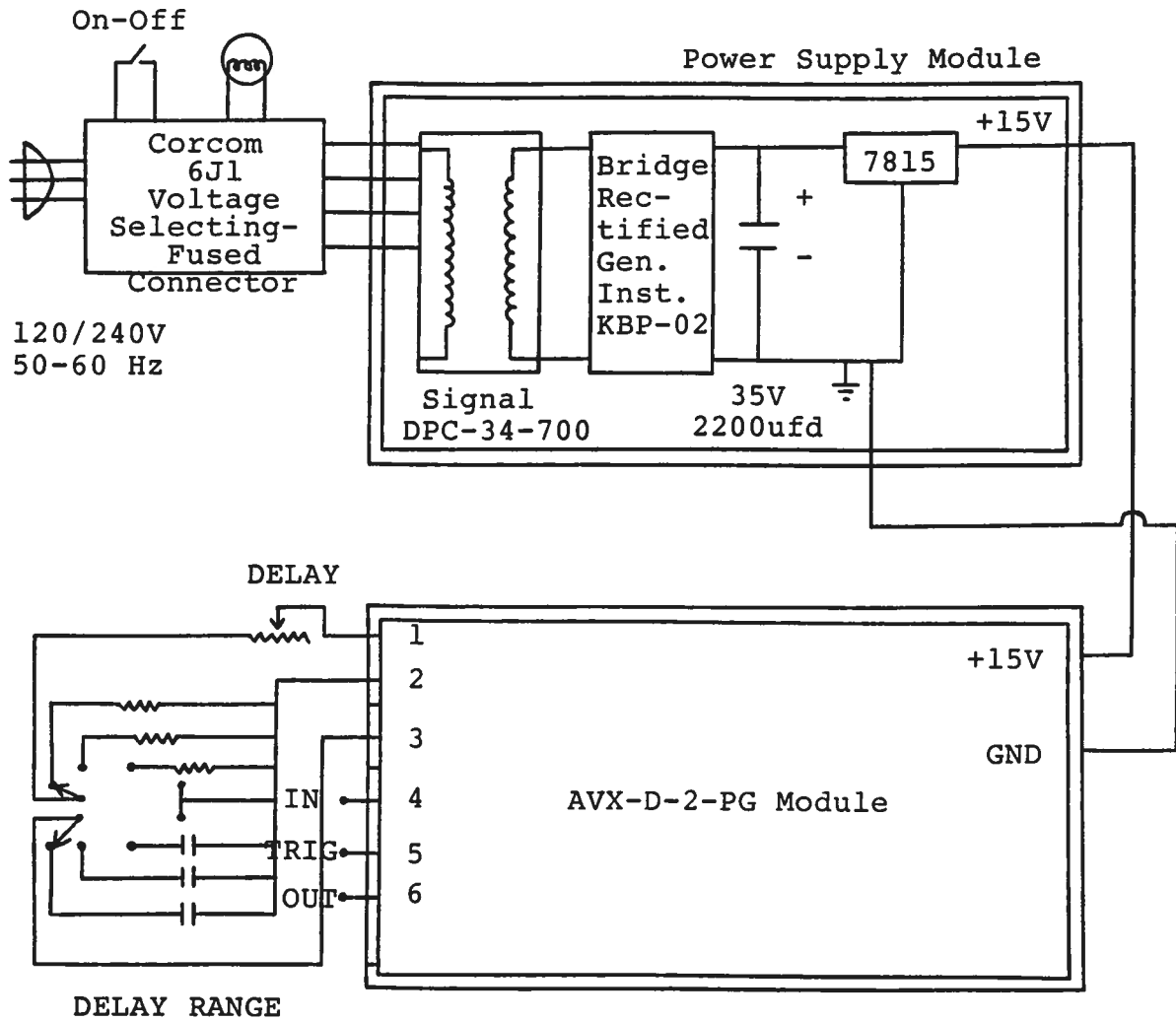

EP

D&PS. INS

AVR-D Disk

July 25 1977