



AVTECH ELECTROSYSTEMS LTD.

NANOSECOND WAVEFORM ELECTRONICS
SINCE 1975

□ P.O. BOX 265
OGDENSBURG, NY
U.S.A. 13669-0265
TEL: (315) 472-5270
FAX: (613) 226-2802

TEL: 1-800-265-6681
FAX: 1-800-561-1970

e-mail: info@avtechpulse.com
<http://www.avtechpulse.com>

□ P.O. BOX 5120 STN. F
OTTAWA, ONTARIO
CANADA K2C 3H4
TEL: (613) 226-5772
FAX: (613) 226-2802

INSTRUCTIONS

MODEL AVX-D-3-PS DELAY GENERATOR

S.N.:

WARRANTY

Avtech Electrosystems Ltd. warrants products of its manufacture to be free from defects in material and workmanship under conditions of normal use. If, within one year after delivery to the original owner, and after prepaid return by the original owner, this Avtech product is found to be defective, Avtech shall at its option repair or replace said defective item. This warranty does not apply to units which have been disassembled, modified or subjected to conditions exceeding the applicable specifications or ratings. This warranty is the extent of the obligation assumed by Avtech with respect to this product and no other warranty or guarantee is either expressed or implied.

TECHNICAL SUPPORT

Phone: 613-226-5772 or 1-800-265-6681

Fax: 613-226-2802 or 1-800-561-1970

E-mail: info@avtechpulse.com

World Wide Web: <http://www.avtechpulse.com>

TABLE OF CONTENTS

WARRANTY 2

TABLE OF CONTENTS 3

SPECIFICATIONS 4

MODEL AVX-D-3 5

GENERAL OPERATING INSTRUCTIONS 6

PERFORMANCE CHECK SHEET 7

SPECIFICATIONS
MODEL AVX-D-3-PS

Model designation:	AVX-D-3-PS						
Delay range:	<table> <thead> <tr> <th>Range</th> <th>Delay (us)</th> </tr> </thead> <tbody> <tr> <td>1</td> <td>1-10 us</td> </tr> <tr> <td>2</td> <td>10-100 us</td> </tr> </tbody> </table>	Range	Delay (us)	1	1-10 us	2	10-100 us
Range	Delay (us)						
1	1-10 us						
2	10-100 us						
PRF range:	0 to 50 KHz						
Jitter:	<table> <tbody> <tr> <td>10 us:</td> <td>< +100 ps</td> </tr> <tr> <td>100 us:</td> <td>< +300 ps</td> </tr> </tbody> </table>	10 us:	< +100 ps	100 us:	< +300 ps		
10 us:	< +100 ps						
100 us:	< +300 ps						
Input PW	50 to 500 ns						
Output PW:	200 to 300 ns						
Trig. PW:	Equals input PW						
Prop delay, IN to TRIG port:	< 30 ns						
Signal amplitudes:	TTL levels Outputs will drive 50 ohm loads						
Power requirements:	120/240V, 50-60 Hz						
Connectors:	BNC						

MODEL AVX-D-3
JITTER AND DELAY TEST ARRANGEMENT

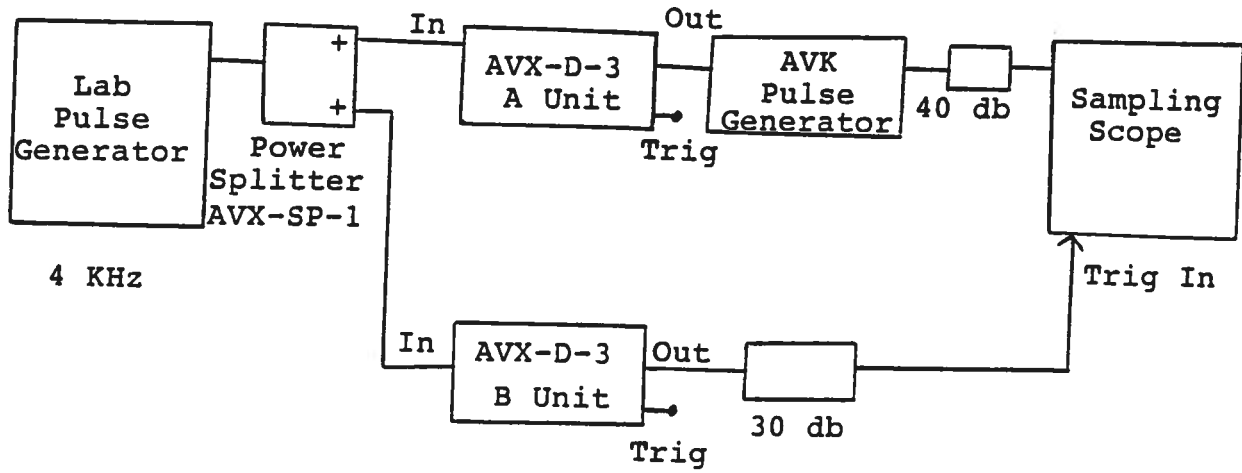

GENERAL OPERATING INSTRUCTIONS

- 1) A worse-case jitter test of the AVX-D-3 unit was conducted using the above arrangement. The use of two delay generators serves to:
 - a) Aggravate the jitter since the resultant jitter is the consequence of two units.
 - b) Allow triggering of the sampling scope with long delays (e.g. 100 us) on the AVX-D-3 units.
- 2) The delays of the A and B units should be such that the time base of the sampling scope is triggered slightly ahead (e.g. 20-100 ns) of the application of the impulse to the vertical amplifier.
- 3) The AVX-D-3 delay can be calibrated by means of a real time scope monitoring the time delay between the IN (or TRIG) and OUT ports.
- 4) The TRIG output provides a +3 Volts coincident replica of the IN pulse.
- 5) The AVH-C unit can be converted from 120 to 240V 50-60 Hz operation by adjusting the voltage selector card in the rear panel fused voltage selector-cable connector assembly.
- 6) For additional assistance:

Tel: (613) 265-6681
Fax: (613) 226-2802

PERFORMANCE CHECK SHEET

Oct 22/98

Edition B

instructword | avx-d | avx-d-3-ps-edb.doc