

AVTECH ELECTROSYSTEMS LTD.

NANOSECOND WAVEFORM ELECTRONICS
ENGINEERING - MANUFACTURING

□ P.O. BOX 265
OGDENSBURG
NEW YORK
13669
(315) 472-5270

☒ BOX 5120, STN. "F"
OTTAWA, ONTARIO
CANADA K2C 3H4
TEL: (613) 226-5772
FAX: (613) 226-2802
TELEX: 053-4591

INSTRUCTIONS

MODEL AVX-S-IBM1-MD BIAS TEE

S.N.:

WARRANTY

Avtech Electrosystems Ltd. warrants products of its manufacture to be free from defects in material and workmanship under conditions of normal use. If, within one year after delivery to the original owner, and after prepaid return by the original owner, this Avtech product is found to be defective, Avtech shall at its option repair or replace said defective item. This warranty does not apply to units which have been disassembled, modified or subjected to conditions exceeding the applicable specifications or ratings. This warranty is the extent of the obligation or liability assumed by Avtech with respect to this product and no other warranty or guarantee is either expressed or implied.

Fig. 1

BIAS INSERTION UNIT TEST ARRANGEMENT

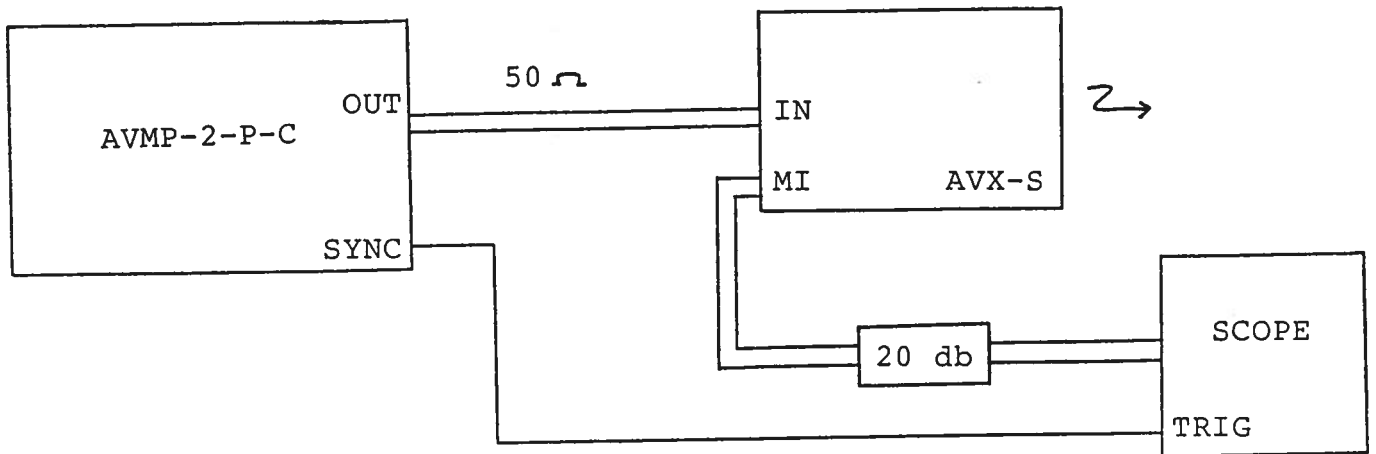
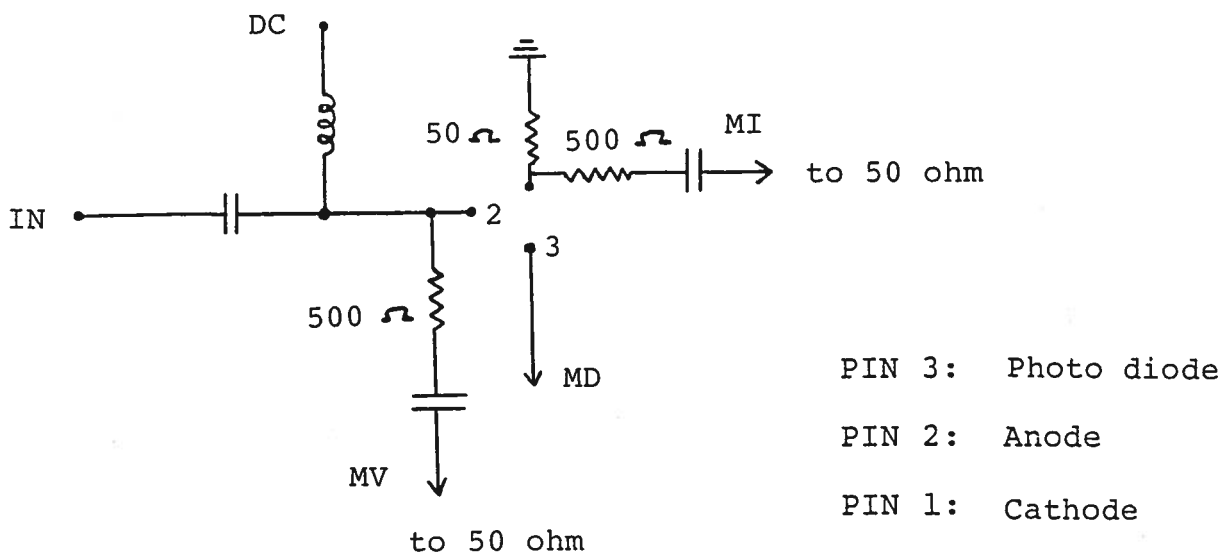

Fig. 2

FUNCTIONAL EQUIVALENT CIRCUIT



Notes:

- 1) The DC terminal of the bias insertion must either be shorted to ground (if a DC offset is not required) or a DC power supply must be applied. The laser diode will not function if the DC terminal is open circuited. Note that the DC current must not exceed ± 100 mA.
- 2) The MI port must be terminated into 50 ohms. Note that a 20 db (or larger) attenuator should be placed between the AVX-S MI output and the scope input since the MI output is very nearly equal to the amplitude of the input drive pulse.
- 3) The diode current I_D (Amps) and the MI output voltage are related as follows:

$$I_D = 0.2 MI$$

- 4) The MV output port also requires a 50 ohm termination. The voltage across the laser diode (V_D) is given by the following:

$$V_D = 10 (MV - MI)$$

where MV and MI are the voltages (into 50 ohms) at the MV and MI output ports.

- 5) The AVX-S input may be a sinusoid in the frequency range of 10 MHz to 1 GHz. For this mode of operation, a DC offset must be applied to the DC terminal.

05.02.90

... ..
... ..
... ..

... ..
... ..
... ..

... ..

... ..

... ..
... ..

... ..

... ..
... ..

... ..
... ..